

Centre Number						Candidate Number				
Surname										
Other Names										
Candidate Signature										

For Examiner's Use	
Examiner's Initials	
Question	Mark
1	
2	
3	
4	
5	
6	
7	
TOTAL	



General Certificate of Secondary Education
Foundation Tier
June 2010

Physics

PHY3F

F

Unit Physics P3

Written Paper

Friday 28 May 2010 9.00 am to 9.45 am

For this paper you must have:

- a ruler.
- You may use a calculator.

Time allowed

- 45 minutes

Instructions

- Use black ink or black ball-point pen.
- Fill in the boxes at the top of this page.
- Answer **all** questions.
- You must answer the questions in the spaces provided. Do not write outside the box around each page or on blank pages.
- Do all rough work in this book. Cross through any work you do not want to be marked.

Information

- The marks for questions are shown in brackets.
- The maximum mark for this paper is 45.
- You are expected to use a calculator where appropriate.
- You are reminded of the need for good English and clear presentation in your answers.

Advice

- In all calculations, show clearly how you work out your answer.



J U N 1 0 P H Y 3 F 0 1

Answer **all** questions in the spaces provided.

1 Two children visit a playground.

1 (a) The diagram shows them on a see-saw. The see-saw is balanced.

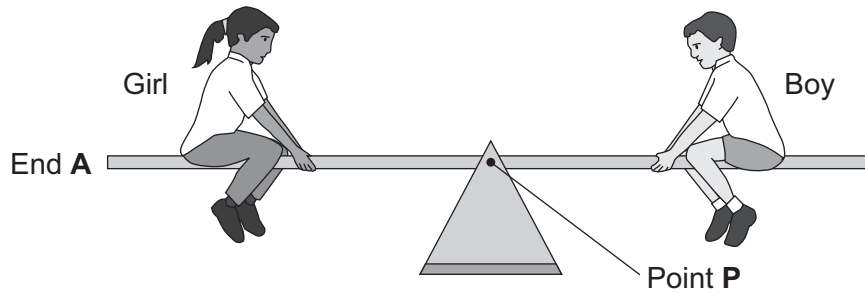

Complete the following sentences by drawing a ring around the correct word or line in the box.

1 (a) (i) The turning effect of the girl's weight is called her

force.

load.

moment.

(1 mark)

1 (a) (ii) Point **P** is the axis of

balance

rotation

turning

of the see-saw.

(1 mark)

1 (a) (iii) To make end **A** of the see-saw go up,

the boy moves nearer to point **P**.

the girl moves nearer to point **P**.

the girl moves nearer to end **A**.

(1 mark)



1 (b) In another part of the playground, a tyre has been suspended from a bar.

1 (b) (i) Draw an **X** on the diagram so that the centre of the **X** marks the centre of mass of the tyre.

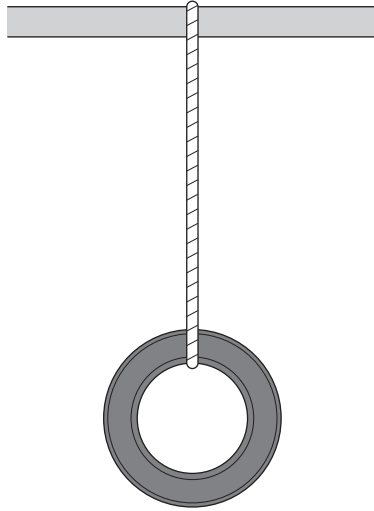

(1 mark)

1 (b) (ii) Complete the sentence by using the correct word or phrase from the box.

above	below	to the left of	to the right of
-------	-------	----------------	-----------------

If the suspended tyre is pushed, it will come to rest with its centre of mass directly the point of suspension.

(1 mark)

5

Turn over for the next question

Turn over ►



2 (a) (i) A sound wave can be represented as a wave on the screen of an oscilloscope.

The diagrams **A**, **B**, **C** and **D** show different screens for the same settings of an oscilloscope.

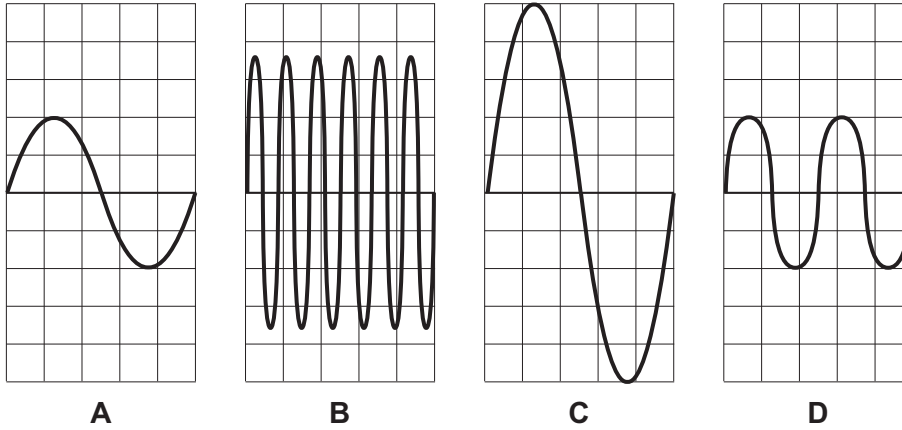

Which diagram represents the sound with the highest frequency?

Diagram

(1 mark)

2 (a) (ii) Complete the sentences using the correct name from the box.

a loudspeaker

a microphone

an ultrasound transmitter

Information is transferred from a sound wave to an oscilloscope by

.....
(1 mark)



2 (b) Complete the sentences by drawing a ring around the correct word in the box.

2 (b) (i) The pitch of a note increases as the

amplitude

frequency

increases.

wavelength

(1 mark)

2 (b) (ii) The loudness of a note decreases as the

amplitude

frequency

decreases.

wavelength

(1 mark)

Question 2 continues on the next page

Turn over ►



2 (c) The diagram shows part of the inside of an electric bell.

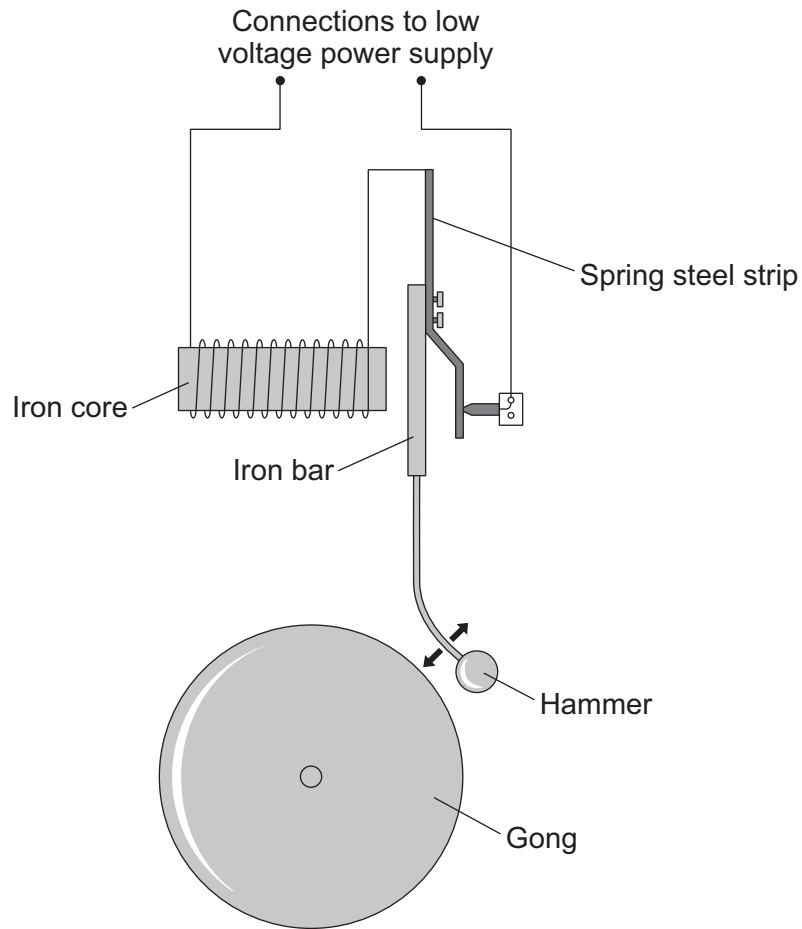

Name the part of the bell which contains the iron core and attracts the iron bar.

..... (1 mark)



- 2 (d)** A group of students use a pump to remove all the air from around a working electric bell in a sealed glass jar.

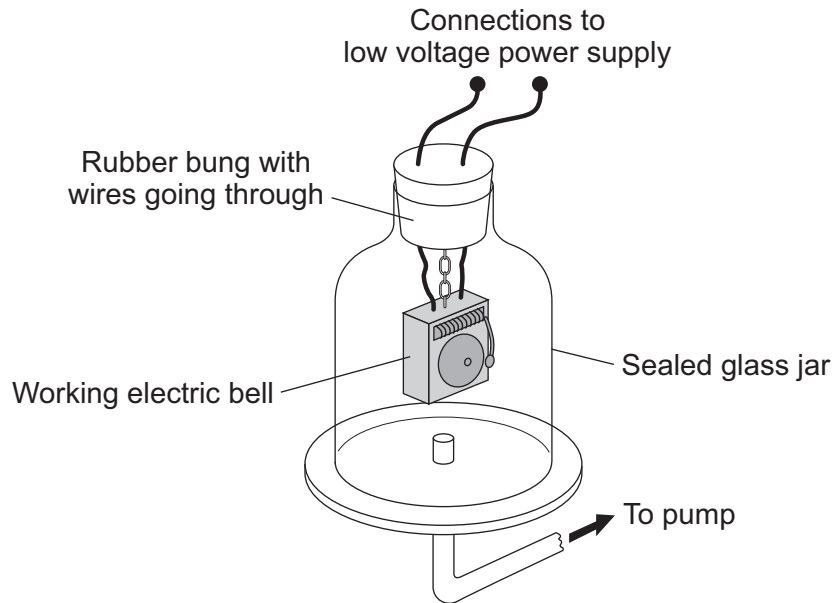

- 2 (d) (i)** What will happen to the sound which they hear from the bell after all the air is removed from the sealed glass jar?

.....

 (1 mark)

- 2 (d) (ii)** Explain your answer to part (d)(i).

.....

 (1 mark)

7

Turn over ►



3 The hammer throw is an athletic event.

The athlete throws a heavy metal ball attached by a wire to a handle.

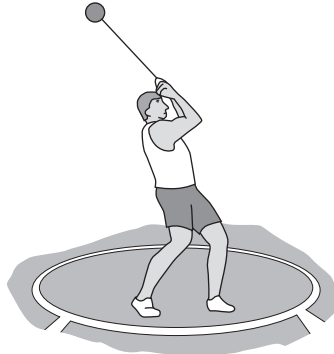

3 (a) The hammer thrower swings the hammer round in a circle before letting go.

He swings the hammer slowly at first and then faster.

Complete the following sentence by drawing a ring around the correct word or line in the box.

As the speed of the swing increases, the centripetal force on the

hammer

decreases.

does not change.

increases.

(1 mark)



- 3 (b)** The diagram shows an overhead view of a hammer thrower swinging the hammer anticlockwise in a circle.

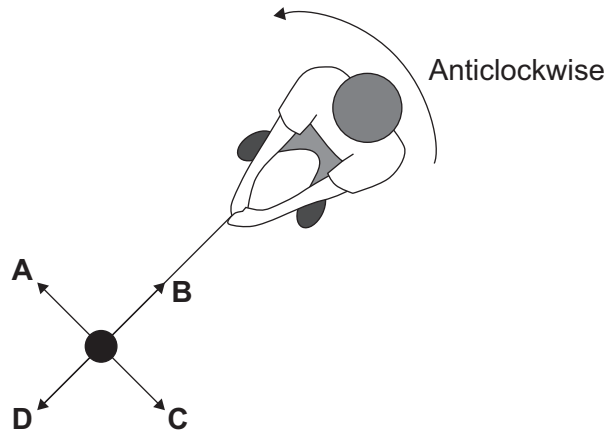

- 3 (b) (i)** In which direction, **A**, **B**, **C** or **D**, does the centripetal force act on the hammer?

(1 mark)

- 3 (b) (ii)** Complete the following sentence by drawing a ring around the correct line in the box.

The centripetal force is provided by the

air resistance.

gravitational force.

tension in the wire.

(1 mark)

- 3 (b) (iii)** At the instant shown in the diagram above, the athlete lets go of the handle.

In which direction, **A**, **B**, **C** or **D**, does the hammer move?

(1 mark)

4

Turn over ►



- 4 A teacher demonstrates a small transformer.

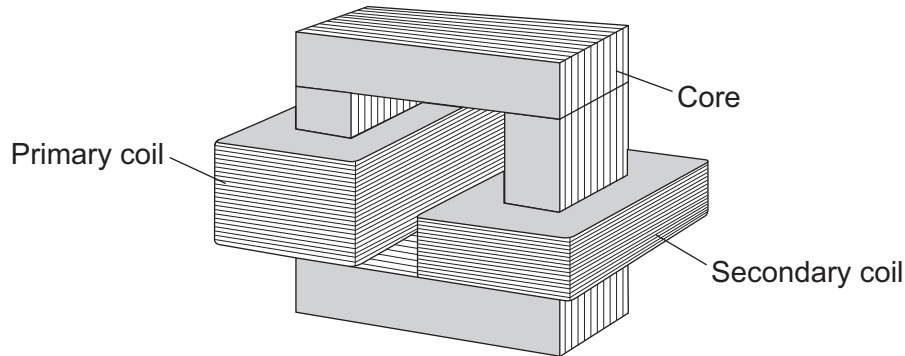

- 4 (a) (i) What is the core made of?

Draw a ring around the correct word in the box.

aluminium	copper	iron
-----------	--------	------

(1 mark)

- 4 (a) (ii) The potential difference (p.d.) across the secondary coil is less than the p.d. across the primary coil.

What sort of transformer is it?

.....
(1 mark)

- 4 (b) Where is a step-up transformer used as part of the National Grid?

.....
(1 mark)



4 (c) The teacher writes a note about the transformer but leaves **five** spaces.

Use the correct words from the box to complete the spaces.

coil	core	current	ends	field	wire
-------------	-------------	----------------	-------------	--------------	-------------

A transformer works because an alternating in the primary produces a changing magnetic in the and then in the secondary coil.

This induces an alternating potential difference across the of the secondary coil.

(5 marks)

8

Turn over for the next question

Turn over ►



5 (a) A student uses a ray box and a curved mirror.

The diagram shows the mirror and parallel rays of light from the ray box.

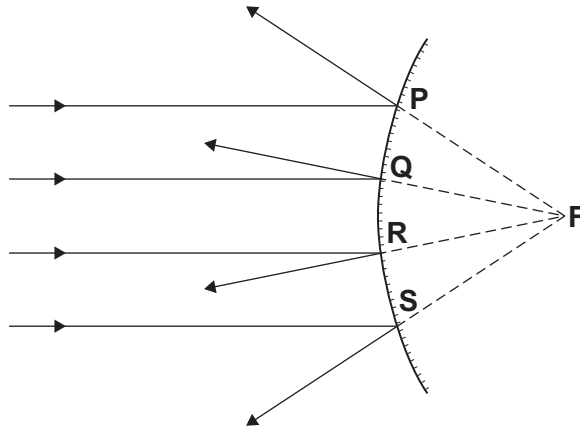

5 (a) (i) What type of mirror is shown in the diagram?

.....
(1 mark)

5 (a) (ii) What is point **F** called?

.....
(1 mark)

5 (a) (iii) What is the process that takes place at points **P**, **Q**, **R** and **S**?

.....
(1 mark)



5 (b) The diagram shows an object and its image in a curved make-up mirror.

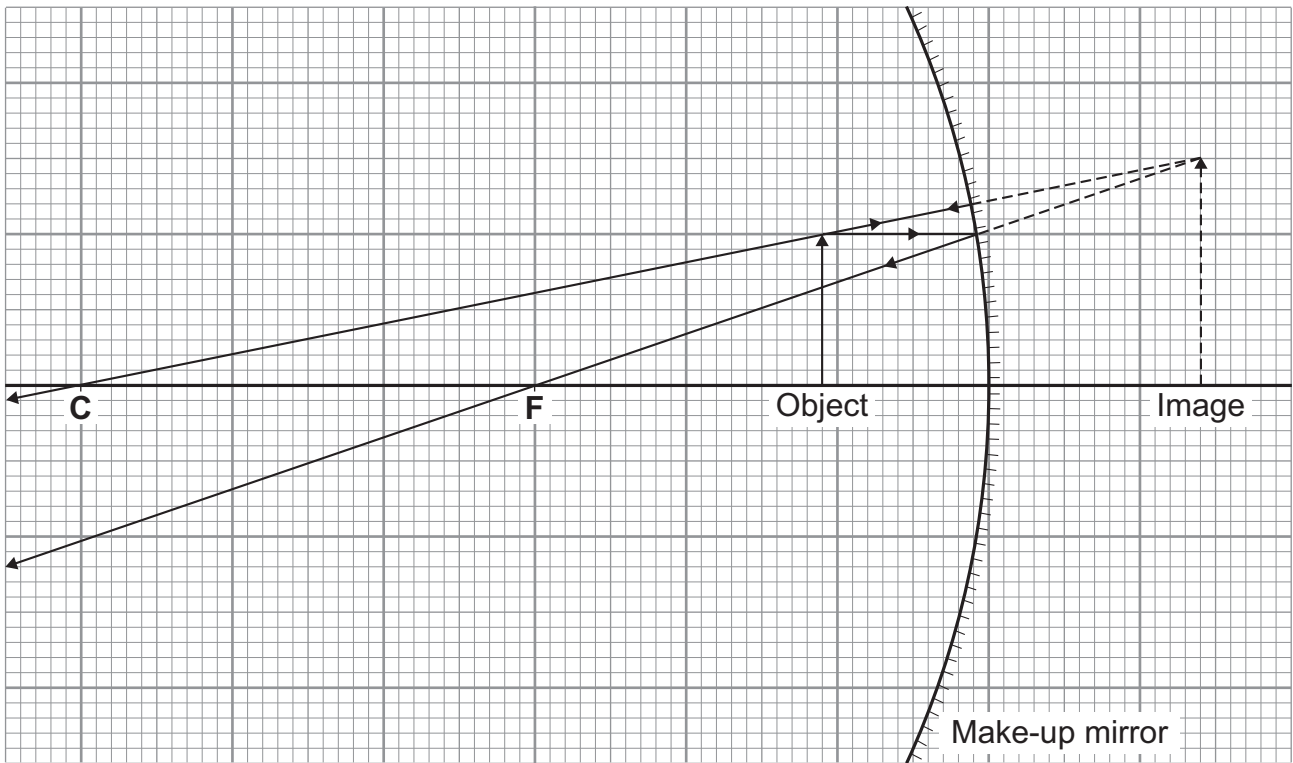

5 (b) (i) What type of mirror is shown in the diagram?

.....
(1 mark)

5 (b) (ii) Use the equation in the box to calculate the magnification produced by the mirror.

$\text{magnification} = \frac{\text{image height}}{\text{object height}}$

Show clearly how you work out your answer.

.....
.....

Magnification =
(2 marks)

6

Turn over ►



- 6 (a)** A student finds data on the Internet for her project on the Solar System. She checks this data on other websites.

The table shows the checked data.

Name of planet	Diameter in km	Distance from Sun in millions of km	Period in days
Mercury	4 840	58	87
Venus	12 390	108	224
Earth	12 760	149	365
Mars	6 800	228	686
Jupiter	142 800	778	4 332
Saturn	119 400	1 428	10 759
Uranus	47 600	2 870	30 685
Neptune	48 400	4 497	60 190

- 6 (a) (i)** In the table, the period of each planet is given in days.

What is meant by the *period* of a planet?

.....
(1 mark)

- 6 (a) (ii)** Suggest why the student checks the data on other websites.

.....
.....
(1 mark)

- 6 (a) (iii)** What is the relationship, if any, between a planet's distance from the Sun and its period?

.....
.....
(1 mark)



6 (a) (iv) What is the relationship, if any, between a planet's diameter and its period?

.....
.....
(1 mark)

6 (b) What is the force which provides the centripetal force to keep planets in their orbits?

.....
(1 mark)

6 (c) What is the name of the galaxy which contains the Solar System?

.....
(1 mark)

6 (d) Complete the following sentence by drawing a ring around the correct word in the box.

The universe is made up of

hundreds
thousands
millions
billions

 of galaxies. (1 mark)

7

Turn over for the next question

Turn over ►



7 (a) Read this passage from a health leaflet.

Most children can hear the full range of sounds which can be detected by the human ear. But as people get older, they cannot hear the higher frequencies.

7 (a) (i) Complete this statement.

Most children can detect sounds in the frequency range

..... Hz to Hz.
(1 mark)

7 (a) (ii) What word is used to describe sound with a frequency so high that it cannot be heard by humans?

.....
(1 mark)

7 (b) Read this cutting from a newspaper.

A shopkeeper has fitted a special loudspeaker outside his store. "We used to have gangs of young people out there," he said, "but now, when I switch on the special loudspeaker, they hate the sound and go away." Older people are not bothered by the sound because the frequency is too high for them to hear it.

Some people support the use of the special loudspeaker but other people do not.

Give **one** reason against its use.

.....
.....
(1 mark)

7 (c) Machines are often very noisy. They transfer energy, and some of the energy is transformed into sound.

What is the cause of the sound?

.....
(1 mark)



7 (d) Sound from a machine may damage the hearing of people who work close by. A safety officer measures the sound intensity at different distances from a noisy machine. The average results are shown on the graph.

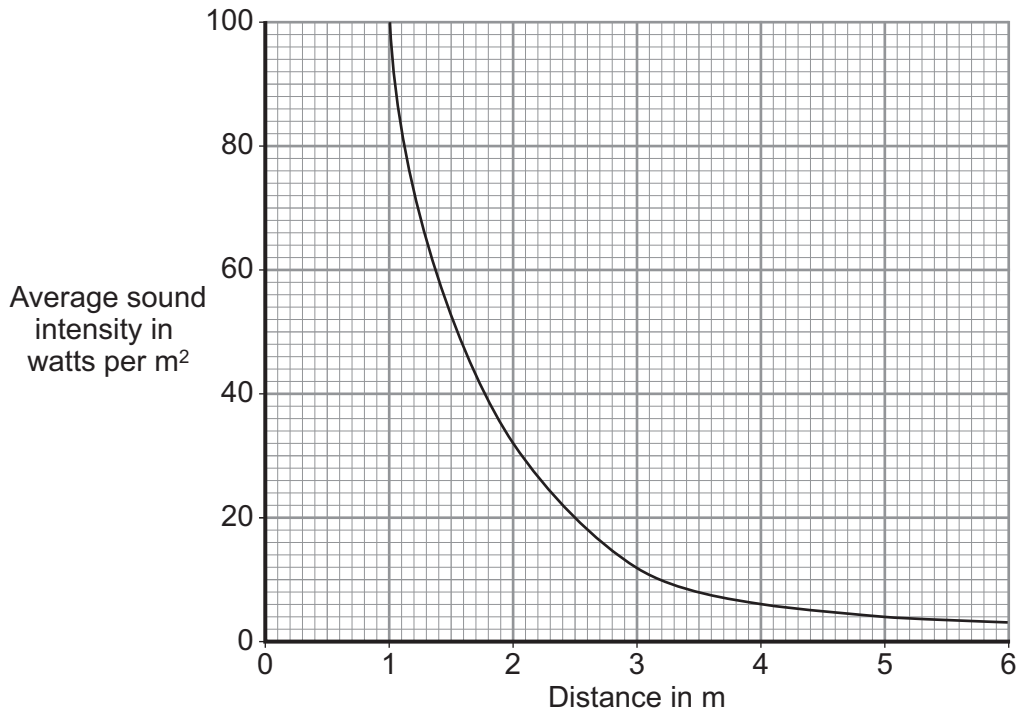

7 (d) (i) Describe the pattern shown by the graph.

Use one or more examples from the graph to support your description.

.....

.....

.....

.....

(2 marks)

7 (d) (ii) Average results were plotted.

Explain why taking results several times and then calculating average values is more reliable than taking only a single result.

.....

.....

.....

.....

(2 marks)

END OF QUESTIONS



There are no questions printed on this page

**DO NOT WRITE ON THIS PAGE
ANSWER IN THE SPACES PROVIDED**



There are no questions printed on this page

**DO NOT WRITE ON THIS PAGE
ANSWER IN THE SPACES PROVIDED**



There are no questions printed on this page

**DO NOT WRITE ON THIS PAGE
ANSWER IN THE SPACES PROVIDED**

ACKNOWLEDGEMENT OF COPYRIGHT-HOLDERS AND PUBLISHERS

Permission to reproduce all copyright material has been applied for. In some cases, efforts to contact copyright-holders have been unsuccessful and AQA will be happy to rectify any omissions of acknowledgements in future papers if notified.

Copyright © 2010 AQA and its licensors. All rights reserved.

