

Surname		Other Names	
Centre Number		Candidate Number	
Candidate Signature			

General Certificate of Secondary Education
June 2006

PHYSICS (SPECIFICATION A) (MODULAR)
Physics in Action (Module 23)

346023



Tuesday 27 June 2006 Morning Session

For this paper you must have:

- a black ball-point pen
- an objective test answer sheet

You may use a calculator.

Time allowed: 30 minutes

Instructions

- Fill in the boxes at the top of this page.
- Check that your name, candidate number and centre number are printed on the separate answer sheet.
- Check that the separate answer sheet has the title 'Physics in Action' printed on it.
- Attempt **one Tier only**, either the Foundation Tier **or** the Higher Tier.
- Make sure that you use the correct side of the separate answer sheet; the Foundation Tier is printed on one side and the Higher Tier on the other.
- Answer **all** the questions for the Tier you are attempting.
- Record your answers on the separate answer sheet only.
- Do all rough work in this book, **not** on your answer sheet.

Instructions for recording answers

- Use a **black ball-point pen**.

- For each answer **completely fill in the circle** as shown:

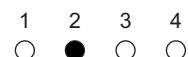

- Do **not** extend beyond the circles.

- If you want to change your answer, **you must** cross out your original answer, as shown:

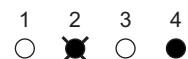

- If you change your mind about an answer you have crossed out and now want to choose it, draw a ring around the cross as shown:

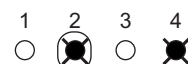

Information

- The maximum mark for this paper is 36.

Advice

- Do **not** choose more responses than you are asked to. You will lose marks if you do.
- Make sure that you hand in both your answer sheet and this question paper at the end of the test.
- If you start to answer on the wrong side of the answer sheet by mistake, make sure that you cross out **completely** the work that is not to be marked.

You must do **one Tier** only, **either** the Foundation Tier **or** the Higher Tier.
The Higher Tier starts on page 14 of this booklet.

FOUNDATION TIER

SECTION A

Questions **ONE** to **FIVE**.

In these questions match words in the list with the numbers.

Use **each** answer only **once**.

Mark your choices on the answer sheet.

QUESTION ONE

The symbols shown can be used in electronic circuit diagrams.



1

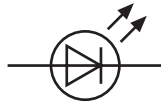

2



3



4

Match words from the list with the symbols **1–4**.

capacitor

LED (light-emitting diode)

NOT gate

resistor

QUESTION TWO

Components in electronic circuits do different jobs.

Match components from the list with the numbers 1–4 in the table.

capacitor

LED (light-emitting diode)

NOT gate

resistor

Component	What it does
1	gives out light
2	gives the opposite of its input
3	reduces the current
4	stores electrical charge

Turn over for the next question

Turn over ►

QUESTION THREE

Broken glass can be a fire hazard.

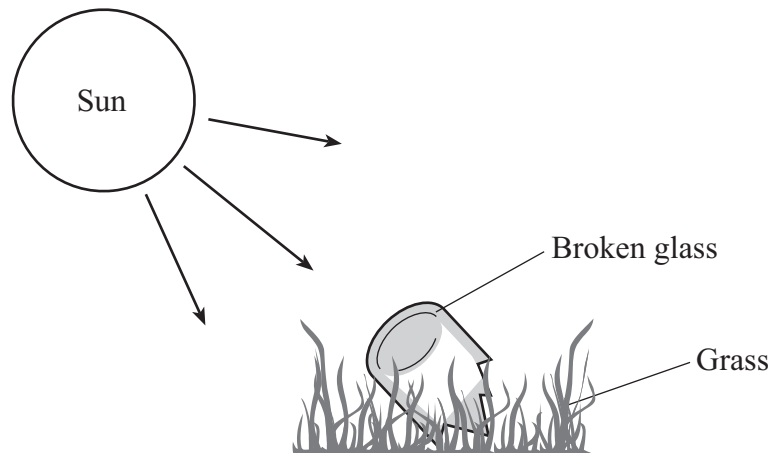

Match words from the list with the numbers **1–4** in the sentences.

burn

converge

focus

lens

The broken glass is curved so it acts as a . . . **1**

The shape of the glass causes light rays from the Sun to . . . **2**

The rays of light are brought to a . . . **3** . . . on the grass.

This grass becomes hot enough to . . . **4**

QUESTION FOUR

This question is about a camera.

Match words from the list with the numbers **1–4** in the sentences.

film

image

lens

object

Light coming from the . . . **1** . . . is focused by the camera's . . . **2**

This causes the . . . **3** . . . to be formed on the . . . **4**

QUESTION FIVE

The table shows four rows taken from truth tables for four logic gates.

Match statements from the list with the numbers **1–4** in the table.

could be an AND gate or an OR gate

must be an AND gate

must be a NOT gate

must be an OR gate

Gate	First input	Second input	Output
1	1	no second input	0
2	1	1	1
3	1	0	1
4	1	0	0

Turn over ►

SECTION BQuestions **SIX** and **SEVEN**.In these questions choose the best **two** answers.Do **not** choose more than two.Mark your choices on the answer sheet.

QUESTION SIX

The diagram shows a potential divider circuit.

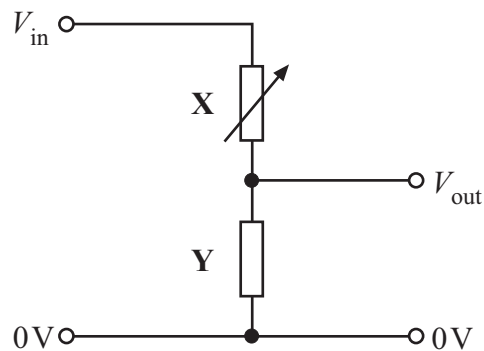
Which **two** statements **P**, **Q**, **R**, **S** and **T** are true about this circuit?

- P** X is a variable resistor
- Q** Y is a fixed capacitor
- R** V_{out} can never be bigger than V_{in}
- S** the current through X is always smaller than the current through Y
- T** the potential difference across Y is always bigger than the potential difference across X

QUESTION SEVEN

The diagram shows a combination of logic gates.

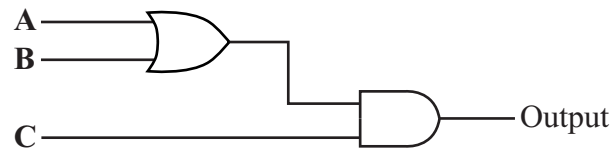

Which **two** rows **J**, **K**, **L**, **M** and **N** in this truth table are correct?

	Inputs			Output
	A	B	C	
J	0	0	0	0
K	1	0	1	0
L	1	0	0	1
M	1	1	0	1
N	1	1	1	1

Turn over for the next question

Turn over ►

SECTION C

Questions **EIGHT** to **TEN**.

Each of these questions has four parts.

In each part choose only **one** answer.

Mark your choices on the answer sheet.

QUESTION EIGHT

The circuit is used to charge a capacitor.

The graph shows how the potential difference (voltage) across the capacitor changes as it is being charged.

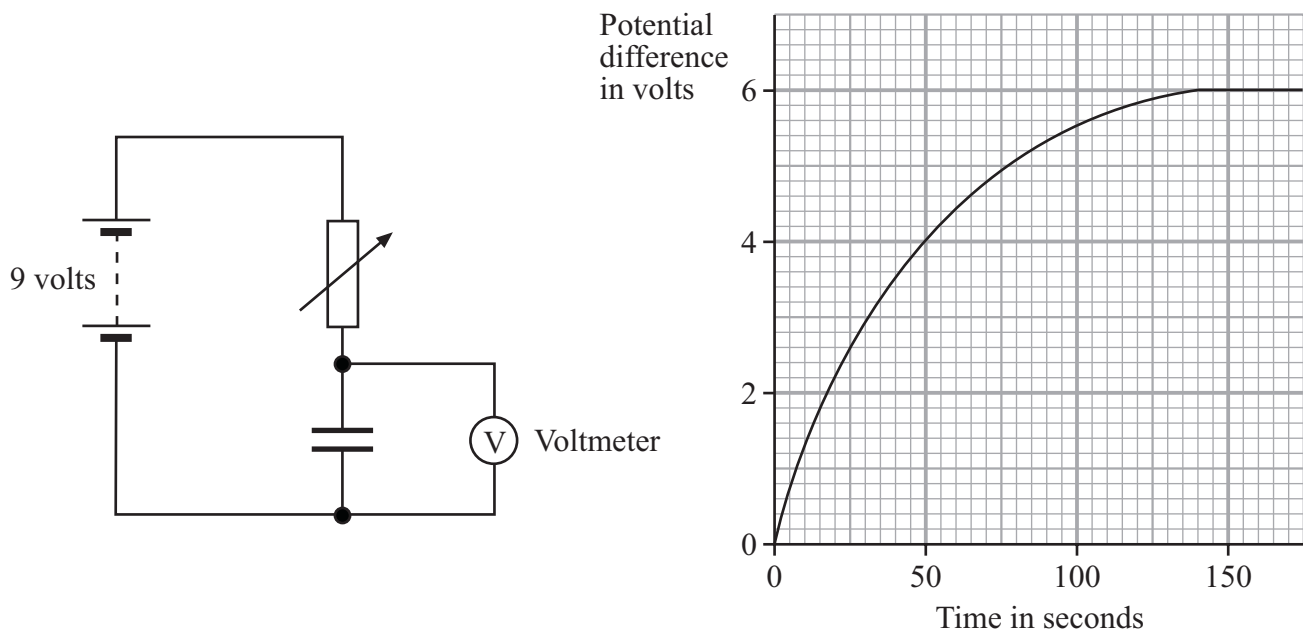

8.1 How long did it take for the potential difference across the capacitor to reach 6 volts?

- A 0 s
- B 75 s
- C 140 s
- D 175 s

8.2 What was the average rate of voltage increase during the first 50 seconds?

- A 0.03 V/s
- B 0.08 V/s
- C 1.00 V/s
- D 4.00 V/s

8.3 In a similar experiment, the variable resistor is adjusted.

It now takes a longer time for the potential difference across the capacitor to reach 4 volts.

This is because . . .

- A the capacitor stores less charge.
- B the capacitor stores more charge.
- C the resistance has been decreased.
- D the resistance has been increased.

8.4 In another similar experiment, a capacitor with a greater value is used.

What can be said about the time it takes for the potential difference across the capacitor to reach 4 volts?

- A It takes a longer time.
- B It takes a shorter time.
- C The time stays the same.
- D The voltage never reaches 4 volts.

Turn over for the next question

Turn over ►

QUESTION NINE

A camera uses a lens to produce an image.

9.1 Which of the diagrams correctly shows parallel rays of light passing through a lens?

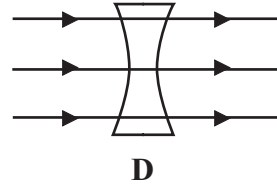
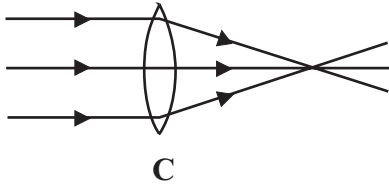
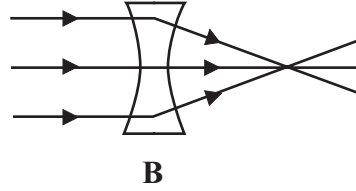
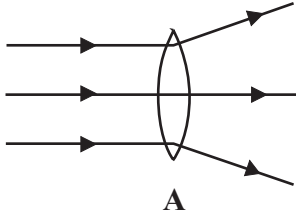

9.2 A diverging lens is inside a frame.

Which diagram correctly shows the position of the focus (F) of the lens?

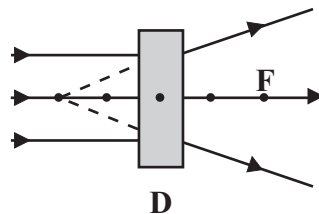
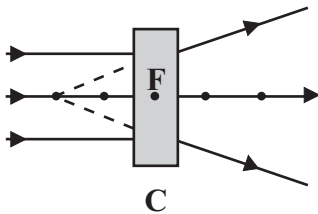
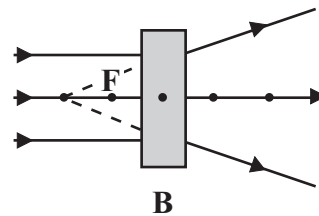
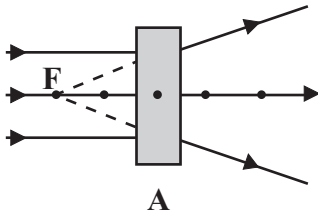

9.3 A camera produces an image on the film.

Which statement describes the image?

- A It is larger than the object, and closer to the lens.
- B It is larger than the object, and further from the lens.
- C It is smaller than the object, and closer to the lens.
- D It is smaller than the object, and further from the lens.

9.4 The camera forms a real image on the film.

Which statement describes a **virtual** image?

- A Rays of light do not pass through it, and it can be formed on a screen.
- B Rays of light do not pass through it, and it cannot be formed on a screen.
- C Rays of light pass through it, and it can be formed on a screen.
- D Rays of light pass through it, and it cannot be formed on a screen.

Turn over for the next question

Turn over ►

QUESTION TEN

A system for putting water into bottles uses this circuit.

The lamp lights when a bottle is almost full.

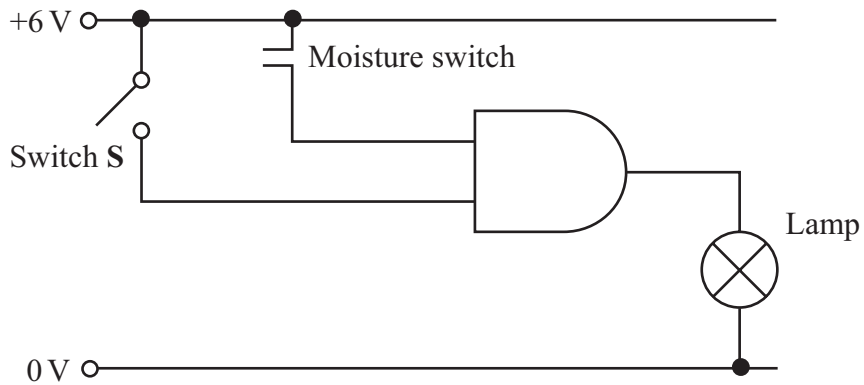

10.1 The logic gate in the circuit is the . . .

- A input sensor.
- B output device.
- C potential divider.
- D processor.

10.2 The moisture switch closes when the water level reaches the probes.

For the lamp to light, . . .

- A both switches have to be closed.
- B either switch can be closed.
- C only switch **S** has to be closed.
- D only the moisture switch has to be closed.

10.3 The manufacturer decides to make a fully automatic system. Instead of lighting the lamp, a conveyor belt replaces the full bottle with an empty one.

What is the output device now?

- A Buzzer
- B Heater
- C Motor
- D Pressure switch

10.4 The new output device needs a larger current. It is turned on and off through a relay.

Where in the arrangement should the relay be placed?

- A After the output from the logic gate, but before the output device
- B Anywhere between the input sensors and the output device
- C Before the input sensors
- D Between the input sensors and the logic gate

END OF TEST

You must do **one Tier** only, **either** the Foundation Tier **or** the Higher Tier.
The Foundation Tier is earlier in this booklet.

HIGHER TIER

SECTION A

Questions **ONE** and **TWO**.

In these questions match words in the list with the numbers.

Use **each** answer only **once**.

Mark your choices on the answer sheet.

QUESTION ONE

The table shows four rows taken from truth tables for four logic gates.

Match statements from the list with the numbers **1–4** in the table.

could be an AND gate or an OR gate

must be an AND gate

must be a NOT gate

must be an OR gate

Gate	First input	Second input	Output
1	1	no second input	0
2	1	1	1
3	1	0	1
4	1	0	0

QUESTION TWO

This circuit shows how a light-dependent resistor (LDR) controls the light output of a light-emitting diode (LED).

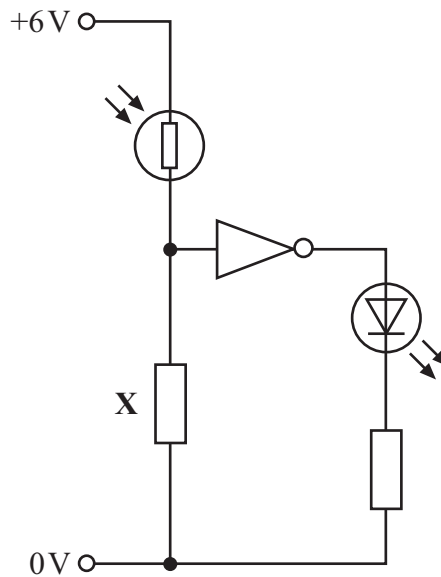

Match statements from the list with the boxes 1–4 in the flow diagram, to explain how the system works.

current flows through the LED

resistance of the LDR becomes very large

NOT gate output goes to high

potential difference across X becomes very small

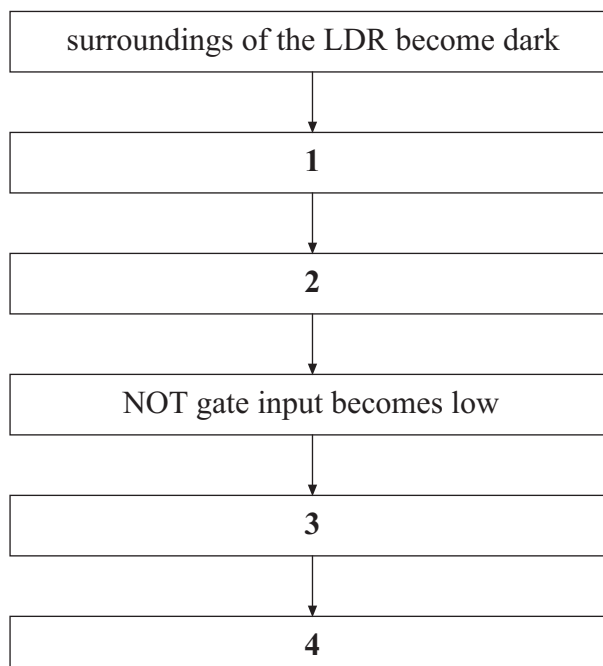

Turn over ►

SECTION BQuestions **THREE** and **FOUR**.In these questions choose the best **two** answers.Do **not** choose more than two.Mark your choices on the answer sheet.

QUESTION THREE

The diagram shows a combination of logic gates.

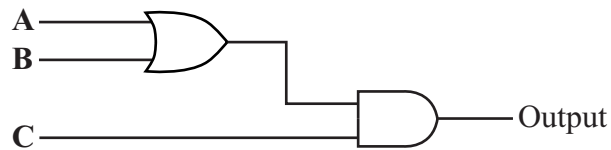
Which **two** rows **J**, **K**, **L**, **M** and **N** in this truth table are correct?

	Inputs			Output
	A	B	C	
J	0	0	0	0
K	1	0	1	0
L	1	0	0	1
M	1	1	0	1
N	1	1	1	1

QUESTION FOUR

You may find the following formula useful when answering this question.

$$V_{\text{out}} = V_{\text{in}} \times \frac{R_2}{R_1 + R_2}$$

Potential dividers are used in electronic circuits.
The diagram shows a potential divider.

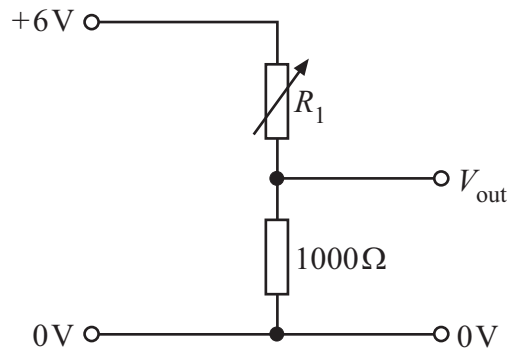

Which **two** rows **V**, **W**, **X**, **Y**, and **Z** in the table are correct?

	R_1	V_{out}
V	200 Ω	5.0 V
W	500 Ω	4.0 V
X	1500 Ω	3.6 V
Y	2500 Ω	2.0 V
Z	5000 Ω	5.0 V

Turn over for the next question

Turn over ►

SECTION C

Questions **FIVE** to **TEN**.

Each of these questions has four parts.

In each part choose only **one** answer.

Mark your choices on the answer sheet.

QUESTION FIVE

The circuit is used to charge a capacitor.

The graph shows how the potential difference (voltage) across the capacitor changes as it is being charged.

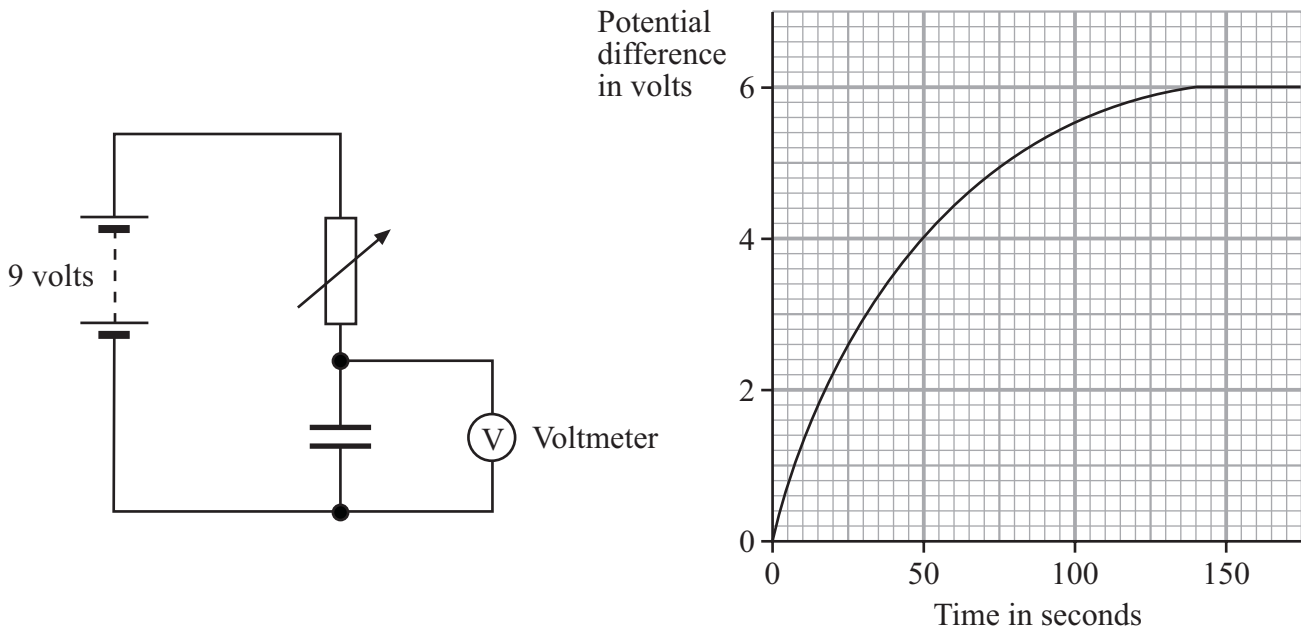

5.1 How long did it take for the potential difference across the capacitor to reach 6 volts?

- A 0 s
- B 75 s
- C 140 s
- D 175 s

5.2 What was the average rate of voltage increase during the first 50 seconds?

- A 0.03 V/s
- B 0.08 V/s
- C 1.00 V/s
- D 4.00 V/s

5.3 In a similar experiment, the variable resistor is adjusted.

It now takes a longer time for the potential difference across the capacitor to reach 4 volts.

This is because . . .

- A the capacitor stores less charge.
- B the capacitor stores more charge.
- C the resistance has been decreased.
- D the resistance has been increased.

5.4 In another similar experiment, a capacitor with a greater value is used.

What can be said about the time it takes for the potential difference across the capacitor to reach 4 volts?

- A It takes a longer time.
- B It takes a shorter time.
- C The time stays the same.
- D The voltage never reaches 4 volts.

Turn over for the next question

Turn over ►

QUESTION SIX

A camera uses a lens to produce an image.

6.1 Which of the diagrams correctly shows parallel rays of light passing through a lens?

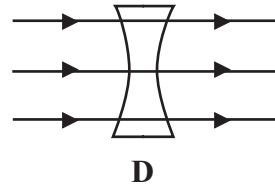
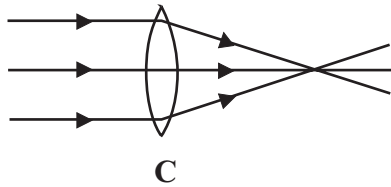
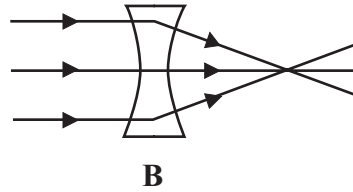
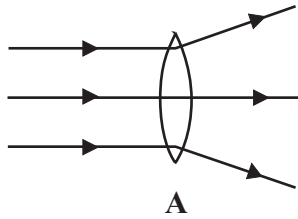

6.2 A diverging lens is inside a frame.

Which diagram correctly shows the position of the focus (F) of the lens?

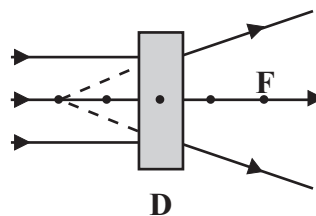
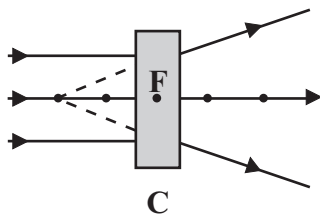
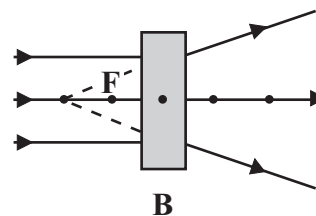
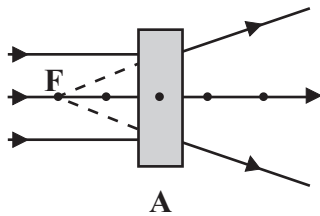

6.3 A camera produces an image on the film.

Which statement describes the image?

- A It is larger than the object, and closer to the lens.
- B It is larger than the object, and further from the lens.
- C It is smaller than the object, and closer to the lens.
- D It is smaller than the object, and further from the lens.

6.4 The camera forms a real image on the film.

Which statement describes a **virtual** image?

- A Rays of light do not pass through it, and it can be formed on a screen.
- B Rays of light do not pass through it, and it cannot be formed on a screen.
- C Rays of light pass through it, and it can be formed on a screen.
- D Rays of light pass through it, and it cannot be formed on a screen.

Turn over for the next question

Turn over ►

QUESTION SEVEN

A system for putting water into bottles uses this circuit.

The lamp lights when a bottle is almost full.

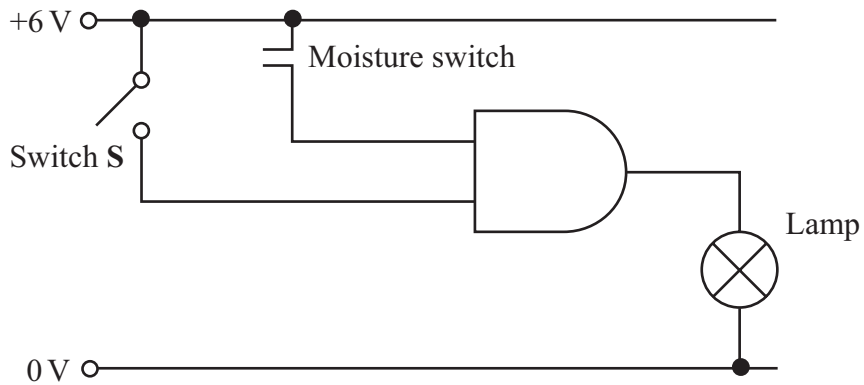

7.1 The logic gate in the circuit is the . . .

- A** input sensor.
- B** output device.
- C** potential divider.
- D** processor.

7.2 The moisture switch closes when the water level reaches the probes.

For the lamp to light, . . .

- A** both switches have to be closed.
- B** either switch can be closed.
- C** only switch **S** has to be closed.
- D** only the moisture switch has to be closed.

- 7.3** The manufacturer decides to make a fully automatic system. Instead of lighting the lamp, a conveyor belt replaces the full bottle with an empty one.

What is the output device now?

- A** Buzzer
 - B** Heater
 - C** Motor
 - D** Pressure switch
- 7.4** The new output device needs a larger current. It is turned on and off through a relay.

Where in the arrangement should the relay be placed?

- A** After the output from the logic gate, but before the output device
- B** Anywhere between the input sensors and the output device
- C** Before the input sensors
- D** Between the input sensors and the logic gate

Turn over for the next question

Turn over ►

QUESTION EIGHT

Cars often use electronic systems.

The electronic system shown below prevents a car from starting when the ignition is switched on, unless all the doors are closed. A bleeper sounds if any door is open when the ignition is switched on.

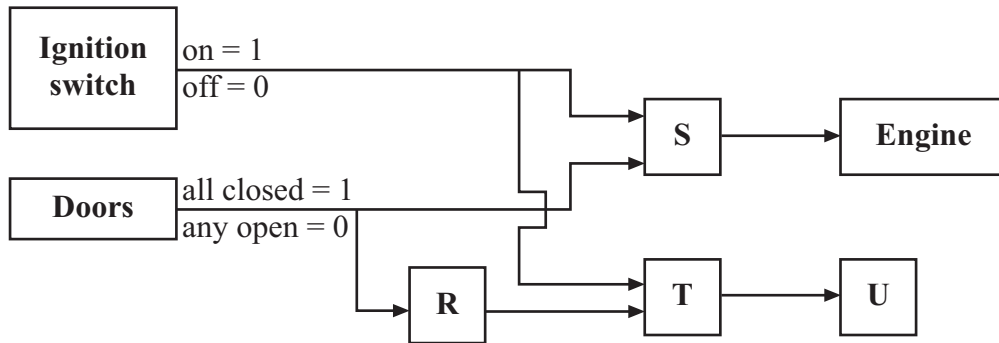

8.1 Component **U** is . . .

- A an AND gate.
- B a bleeper.
- C a NOT gate.
- D an OR gate.

8.2 Component **R** could be . . .

- A an AND gate.
- B a NOT gate.
- C an OR gate.
- D a relay.

8.3 You could use AND gates at . . .

- A **R** and **S**
- B **S** and **T**
- C **S** only
- D **T** only

8.4 A student writes that, if **S** is an OR gate, then the engine

- will start when the ignition is switched on, even if a door is open
- will start as soon as all the doors are closed.

Which of these statements is correct?

- A** Both are correct
- B** Neither is correct
- C** Only the first is correct
- D** Only the second is correct

Turn over for the next question

Turn over ►

QUESTION NINE

The diagram shows a convex lens forming a virtual image. The diagram is drawn to scale.

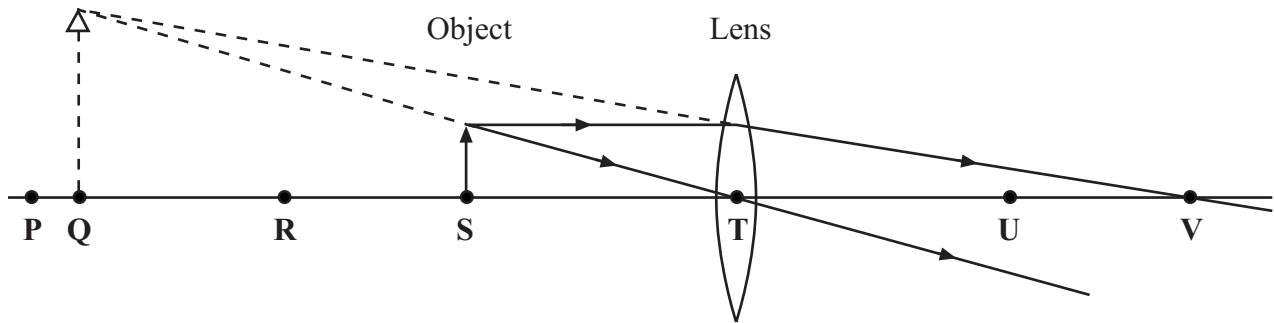

9.1 The image is formed at . . .

- A P
- B Q
- C R
- D S

9.2 The image is . . .

- A upright and larger than the object.
- B upright and smaller than the object.
- C upside down and larger than the object.
- D upside down and smaller than the object.

9.3 The focus of the lens is at . . .

- A Q
- B S
- C T
- D V

9.4 A real image could be produced with this lens by placing the object between . . .

- A** P and R.
- B** R and S.
- C** S and T.
- D** T and U.

Turn over for the next question

Turn over ►

QUESTION TEN

You may find the following formula useful when answering this question.

$$V_{\text{out}} = V_{\text{in}} \times \frac{R_2}{R_1 + R_2}$$

In the potential divider circuit shown below, a thermistor is used as an input sensor.

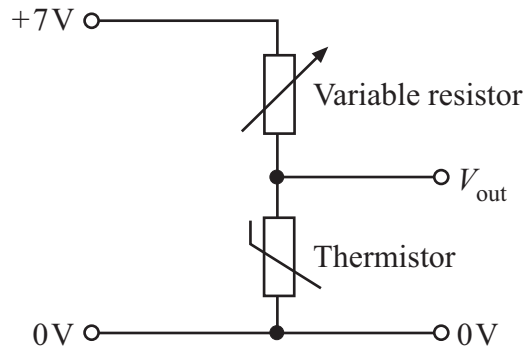

The table shows the resistance of the thermistor at different temperatures.

Temperature	Resistance of thermistor
0°C	1200 Ω
24°C	500 Ω
60°C	100 Ω

10.1 At 0°C, the value of V_{out} is 6 V.

What is the value of the variable resistor?

- A Zero
- B 200 ohms
- C 600 ohms
- D 1000 ohms

10.2 The temperature of the surroundings rises from 0°C to 24°C.

The resistance of the thermistor . . .

- A decreases by 500 ohms.
- B decreases by 700 ohms.
- C increases by 500 ohms.
- D increases by 700 ohms.

10.3 The variable resistor is set to 400 ohms. The temperature is 60°C.

What is the value of V_{out} ?

- A 0.8 V
- B 1.4 V
- C 4.2 V
- D 5.6 V

10.4 V_{out} is fed to a processor which reads V_{out} as high at temperatures up to 60°C.

How can the system be altered so that V_{out} changes from high to low at 24°C?

- A Adjust the variable resistor to a higher resistance
- B Adjust the variable resistor to a lower resistance
- C Put a fixed resistor in series with the thermistor
- D Replace the thermistor with another variable resistor

END OF TEST

There are no questions printed on this page

There are no questions printed on this page

There are no questions printed on this page