

Surname		Other Names	
Centre Number		Candidate Number	
Candidate Signature			

General Certificate of Secondary Education
Spring 2004



PHYSICS (MODULAR)
Physics in Action (Module 23)

346023

Wednesday 3 March 2004 Morning Session

In addition to this paper you will require:

- a black ball-point pen;
- an answer sheet.

You may use a calculator.

Time allowed: 30 minutes

Instructions

- Fill in the boxes at the top of this page.
- Check that your name, candidate number and centre number are printed on the separate answer sheet.
- Check that the separate answer sheet has the title “Physics in Action” printed on it.
- Attempt **one Tier only**, either the Foundation Tier or the Higher Tier.
- Make sure that you use the correct side of the separate answer sheet; the Foundation Tier is printed on one side and the Higher Tier on the other.
- Answer **all** the questions for the Tier you are attempting.
- Record your answers on the separate answer sheet only. Rough work may be done on the question paper.

Instructions for recording answers

- Use a **black ball-point pen**.

- For each answer **completely fill in the circle** as shown:

1	2	3	4
<input type="radio"/>	<input checked="" type="radio"/>	<input type="radio"/>	<input type="radio"/>

- Do **not** extend beyond the circles.

- If you want to change your answer, **you must** cross out your original answer, as shown:

1	2	3	4
<input type="radio"/>	<input checked="" type="radio"/>	<input type="radio"/>	<input checked="" type="radio"/>

- If you change your mind about an answer you have crossed out and now want to choose it, draw a ring around the cross as shown:

1	2	3	4
<input type="radio"/>	<input checked="" type="radio"/>	<input type="radio"/>	<input checked="" type="radio"/>

Information

- The maximum mark for this paper is 36.

Advice

- Do **not** choose more responses than you are asked to. You will lose marks if you do.
- Make sure that you hand in both your answer sheet and this question paper at the end of the test.
- If you start to answer on the wrong side of the answer sheet by mistake, make sure that you cross out **completely** the work that is not to be marked.

You must do **one Tier** only, **either** the Foundation Tier **or** the Higher Tier.
The Higher Tier starts on page 14 of this booklet.

FOUNDATION TIER

SECTION A

Questions **ONE** to **FIVE**.

In these questions match the words in the list with the numbers.

Use **each** answer only **once**.

Mark your choices on the answer sheet.

QUESTION ONE

Match electrical devices from the list with the numbers **1–4** in the table.

LDR

magnetic switch

thermistor

tilt switch

Device	What the electrical device does
1	detects changes in angle
2	detects changes in the brightness of light
3	detects changes in magnetic fields
4	detects changes in temperature

QUESTION TWO

Electronic systems contain different types of device.

Match devices from the list with the numbers 1–4 in the table.

input sensor

processor

relay

variable resistor

Device	What the device is used for
1	as a switch
2	as part of a potential divider
3	to detect changes in the environment
4	to make decisions on the action to take

QUESTION THREE

Match words from the list with the numbers 1–4 in the sentences.

AND gates

buzzers

LEDs

pressure switches

..... 1 are used in processors.

..... 2 can be used in input sensors.

..... 3 produce light in output devices.

..... 4 produce sound in output devices.

Turn over ►

QUESTION FOUR





Match components from the list with the numbers 1–4 in the table.

capacitor

LED

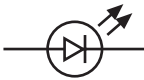
NOT gate

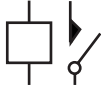
relay

Component	Symbol
1	
2	
3	
4	

QUESTION FIVE

Match words from the list with the spaces **1–4** in the sentences.

charge

current

potential difference (voltage)

resistance

A capacitor stores electric **1**

When its plates are connected by a conductor, the **2** across the capacitor decreases.

The greater the **3** of the circuit, the longer it takes the capacitor to discharge.

The discharge **4** may be measured using an ammeter.

TURN OVER FOR THE NEXT QUESTION

Turn over ►

SECTION BQuestions **SIX** and **SEVEN**.In these questions choose the best **two** answers.Do **not** choose more than two.Mark your choices on the answer sheet.

QUESTION SIX

Optical devices use lenses to produce images.

Which **two** of the following statements, **P**, **Q**, **R**, **S** and **T**, are **not** correct?

- P** cameras use converging lenses to produce real images on the film
- Q** converging lenses never produce real images
- R** in a camera, the distance of the image from the lens is less than the distance of the object from the lens
- S** real images can be produced on a screen
- T** the image formed by a camera lens is usually larger than the object

QUESTION SEVEN

The diagram shows an electronic system.

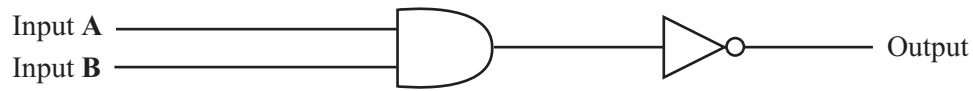

A truth table is shown below.

	Input A	Input B	Output
W	0	0	1
X	0	1	0
Y	1	0	1
Z	1	1	0

Which **two** of the following statements are correct?

all the lines in the table are correct

lines W and Y are correct

lines X and Z are correct

line X is the only line which is wrong

line Z is the only line which is wrong

TURN OVER FOR THE NEXT QUESTION

Turn over ►

SECTION CQuestions **EIGHT** to **TEN**.

Each of these questions has four parts.

In each part choose only **one** answer.Mark your choices on the answer sheet.

QUESTION EIGHT

A baby alarm has an electronic system, which gives an audible warning in another room, when the temperature of the baby's room is too high.

8.1 What is the input sensor to the system?

- A A buzzer
- B An LDR
- C A moisture switch
- D A thermistor

8.2 What is the output device of the system?

- A A buzzer
- B An LDR
- C A moisture switch
- D A thermistor

The baby alarm also needs to give a warning if the mattress cover gets wet.

8.3 What additional input sensor is needed?

- A A buzzer
- B An LDR
- C A moisture switch
- D A thermistor

The truth table for the system is shown below.

Input 1	Input 2	Output
0	0	0
0	1	1
1	0	1
1	1	1

8.4 This is the truth table for

- A an AND gate.
- B a NOT gate.
- C an OR gate.
- D an OR gate followed by a NOT gate.

TURN OVER FOR THE NEXT QUESTION

Turn over ►

QUESTION NINE

A security light is needed to come on at night, when someone stands on a doormat. An electronic system, which does not work properly, is shown below.

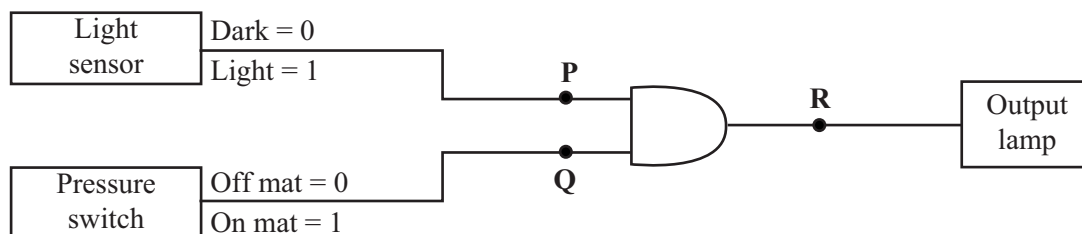

9.1 Using this system, as it is in the diagram, when will the light be on?

- A When it is dark, and no-one is standing on the mat
- B When it is dark, and someone is standing on the mat
- C When it is light, and no-one is standing on the mat
- D When it is light, and someone is standing on the mat

9.2 To make the system work properly, another logic gate must be added to the system.

Which is the best gate to add?

- A A NOT gate at P
- B A NOT gate at Q
- C A NOT gate at R
- D An OR gate at R

The security light stays on for a set time. The circuit which controls this part of the system contains a capacitor and a resistor. The capacitor discharges through the resistor.

9.3 Which of the following statements about the discharge of a capacitor is correct?

- A As the capacitor discharges, current flows through the capacitor
- B As the capacitor discharges, the charge stored increases
- C As the capacitor discharges, the current in the circuit increases
- D As the capacitor discharges, the potential difference (voltage) across it decreases

9.4 To increase the time that the light stays on, the time taken for the capacitor to discharge must be increased.

This may be done by

- A** decreasing the value of the capacitor.
- B** decreasing the value of the resistor.
- C** decreasing the value of both the capacitor and the resistor.
- D** increasing the value of either the capacitor or the resistor.

TURN OVER FOR THE NEXT QUESTION

Turn over ►

QUESTION TEN

The diagram shows a circuit containing an LDR.

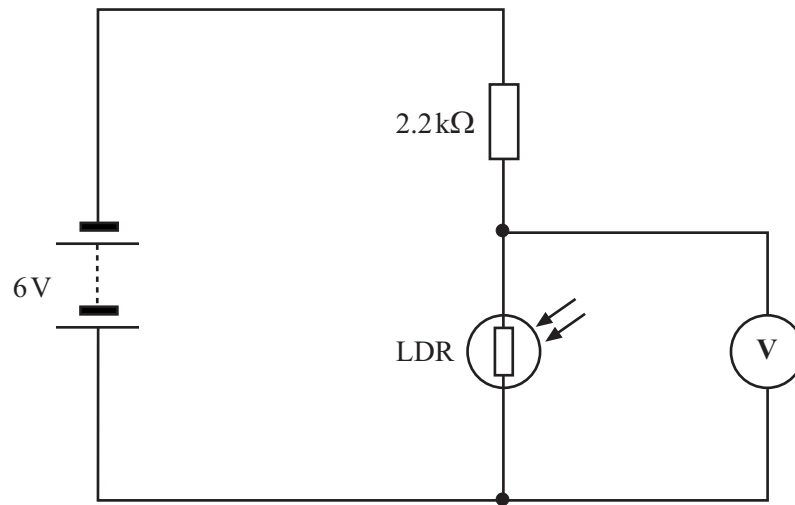

10.1 The circuit shown is the basis of

- A a processor.
- B a relay.
- C an input sensor.
- D an output device.

10.2 It becomes darker. Which statement is correct?

- A The reading on the voltmeter goes down
- B The reading on the voltmeter goes up
- C The reading on the voltmeter stays the same
- D Without further information we cannot tell what the voltmeter reading will do

The LDR has a resistance of $1100\ \Omega$ in the light, and $12.8\ \text{k}\Omega$ in the dark.

You may find the following formula useful when answering the next questions.

$$V_{\text{out}} = V_{\text{in}} \times \frac{R_2}{(R_1 + R_2)}$$

10.3 In the dark, the reading on the voltmeter will be

- A 0.88 V
- B 5.12 V
- C 7.03 V
- D 40.90 V

10.4 In the light, the reading on the voltmeter will be

- A 2 V
- B 4 V
- C 9 V
- D 18 V

END OF TEST

You must do **one Tier** only, **either** the Foundation Tier **or** the Higher Tier.
The Foundation Tier is earlier in this booklet.

HIGHER TIER

SECTION A

Questions **ONE** and **TWO**.

In these questions match the words in the list with the numbers.

Use **each** answer only **once**.

Mark your choices on the answer sheet.

QUESTION ONE

Match words from the list with the spaces **1–4** in the sentences.

charge

current

potential difference (voltage)

resistance

A capacitor stores electric **1**

When its plates are connected by a conductor, the **2** across the capacitor decreases.

The greater the **3** of the circuit, the longer it takes the capacitor to discharge.

The discharge **4** may be measured using an ammeter.

QUESTION TWO

The diagram shows part of a circuit.

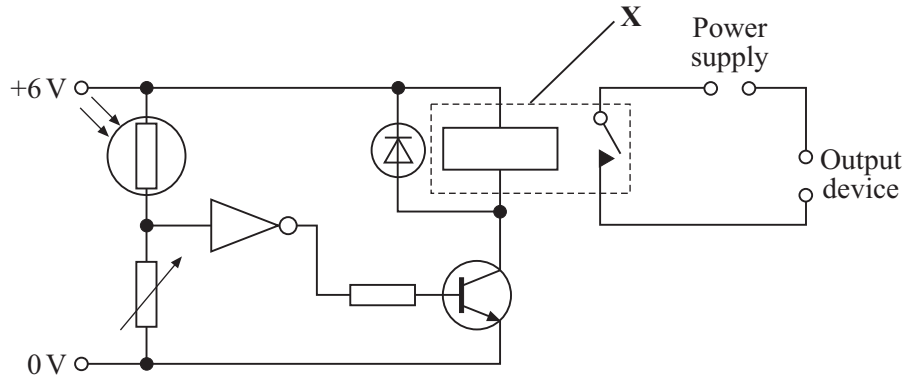

The component labelled **X** is used to make one circuit switch on another circuit which needs a bigger current.

Choose words from the list to match the numbers 1–4 in the sentences.

buffer

diode

relay

transistor

A **1** is used as a **2** for high output currents.

The **3** protects the **4** when **X** is switched off.

TURN OVER FOR THE NEXT QUESTION

Turn over ►

SECTION BQuestions **THREE** and **FOUR**.In these questions choose the best **two** answers.Do **not** choose more than two.

Mark your choices on the answer sheet.

QUESTION THREE

The diagram shows an electronic system.

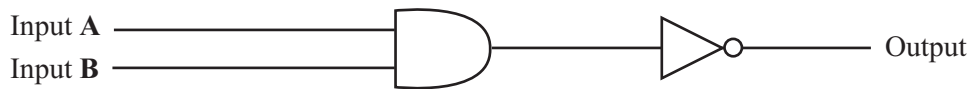

A truth table is shown below.

	Input A	Input B	Output
W	0	0	1
X	0	1	0
Y	1	0	1
Z	1	1	0

Which **two** of the following statements are correct?**all the lines in the table are correct****lines W and Y are correct****lines X and Z are correct****line X is the only line which is wrong****line Z is the only line which is wrong**

QUESTION FOUR

The diagram shows how an image is formed in a camera.

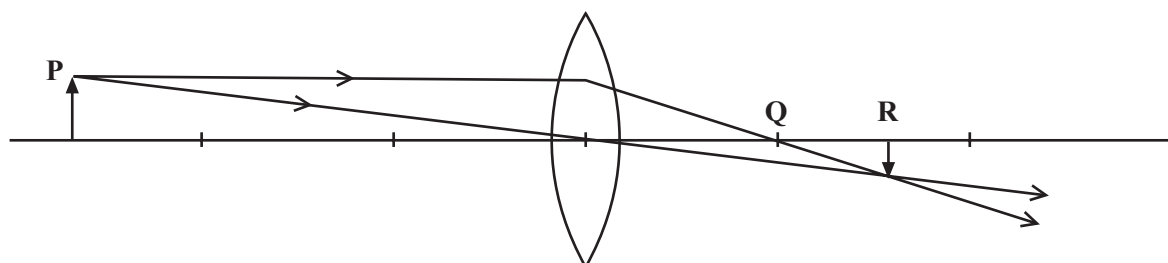

Which **two** of the following statements are correct?

P can be closer to the lens than R is to the lens

P is drawn to represent the object

Q is the focus of the diverging lens

R shows the position of the virtual image

the image is smaller than the object

TURN OVER FOR THE NEXT QUESTION

Turn over ►

SECTION CQuestions **FIVE** to **TEN**.

Each of these questions has four parts.

In each part choose only **one** answer.Mark your choices on the answer sheet.

QUESTION FIVE

A baby alarm has an electronic system, which gives an audible warning in another room, when the temperature of the baby's room is too high.

5.1 What is the input sensor to the system?

- A** A buzzer
- B** An LDR
- C** A moisture switch
- D** A thermistor

5.2 What is the output device of the system?

- A** A buzzer
- B** An LDR
- C** A moisture switch
- D** A thermistor

The baby alarm also needs to give a warning if the mattress cover gets wet.

5.3 What additional input sensor is needed?

- A** A buzzer
- B** An LDR
- C** A moisture switch
- D** A thermistor

The truth table for the system is shown below.

Input 1	Input 2	Output
0	0	0
0	1	1
1	0	1
1	1	1

5.4 This is the truth table for

- A an AND gate.
- B a NOT gate.
- C an OR gate.
- D an OR gate followed by a NOT gate.

TURN OVER FOR THE NEXT QUESTION

Turn over ►

QUESTION SIX

A security light is needed to come on at night, when someone stands on a doormat. An electronic system, which does not work properly, is shown below.

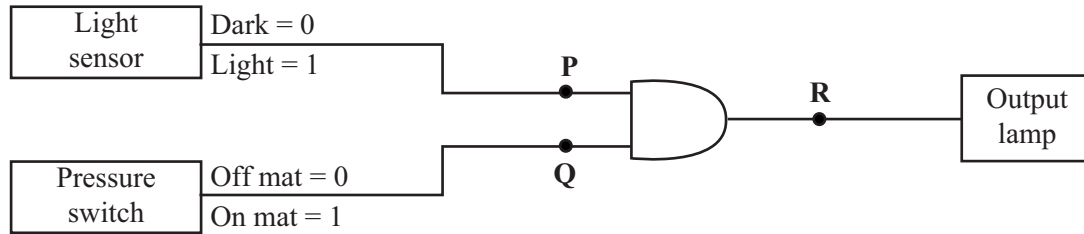

- 6.1** Using this system, as it is in the diagram, when will the light be on?
- A** When it is dark, and no-one is standing on the mat
 - B** When it is dark, and someone is standing on the mat
 - C** When it is light, and no-one is standing on the mat
 - D** When it is light, and someone is standing on the mat
- 6.2** To make the system work properly, another logic gate must be added to the system.
- Which is the best gate to add?
- A** A NOT gate at **P**
 - B** A NOT gate at **Q**
 - C** A NOT gate at **R**
 - D** An OR gate at **R**

The security light stays on for a set time. The circuit which controls this part of the system contains a capacitor and a resistor. The capacitor discharges through the resistor.

- 6.3** Which of the following statements about the discharge of a capacitor is correct?
- A** As the capacitor discharges, current flows through the capacitor
 - B** As the capacitor discharges, the charge stored increases
 - C** As the capacitor discharges, the current in the circuit increases
 - D** As the capacitor discharges, the potential difference (voltage) across it decreases

6.4 To increase the time that the light stays on, the time taken for the capacitor to discharge must be increased.

This may be done by

- A** decreasing the value of the capacitor.
- B** decreasing the value of the resistor.
- C** decreasing the value of both the capacitor and the resistor.
- D** increasing the value of either the capacitor or the resistor.

TURN OVER FOR THE NEXT QUESTION

Turn over ►

QUESTION SEVEN

The diagram shows a circuit containing an LDR.

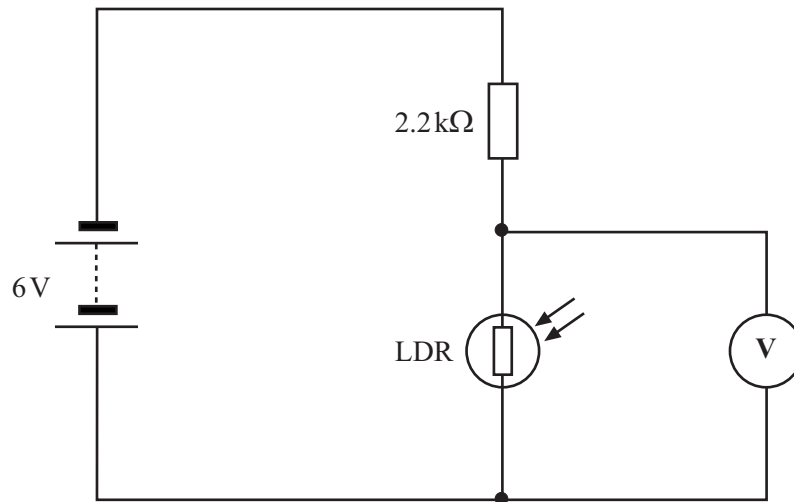

7.1 The circuit shown is the basis of

- A a processor.
- B a relay.
- C an input sensor.
- D an output device.

7.2 It becomes darker. Which statement is correct?

- A The reading on the voltmeter goes down
- B The reading on the voltmeter goes up
- C The reading on the voltmeter stays the same
- D Without further information we cannot tell what the voltmeter reading will do

The LDR has a resistance of $1100\ \Omega$ in the light, and $12.8\ \text{k}\Omega$ in the dark.

You may find the following formula useful when answering the next questions.

$$V_{\text{out}} = V_{\text{in}} \times \frac{R_2}{(R_1 + R_2)}$$

7.3 In the dark, the reading on the voltmeter will be

- A 0.88 V
- B 5.12 V
- C 7.03 V
- D 40.90 V

7.4 In the light, the reading on the voltmeter will be

- A 2 V
- B 4 V
- C 9 V
- D 18 V

TURN OVER FOR THE NEXT QUESTION

Turn over ►

QUESTION EIGHT

The diagram shows part of a control circuit for a model railway signalling system. The LEDs for green (**G**), yellow (**Y**) and red (**R**) are controlled by a system of logic gates.

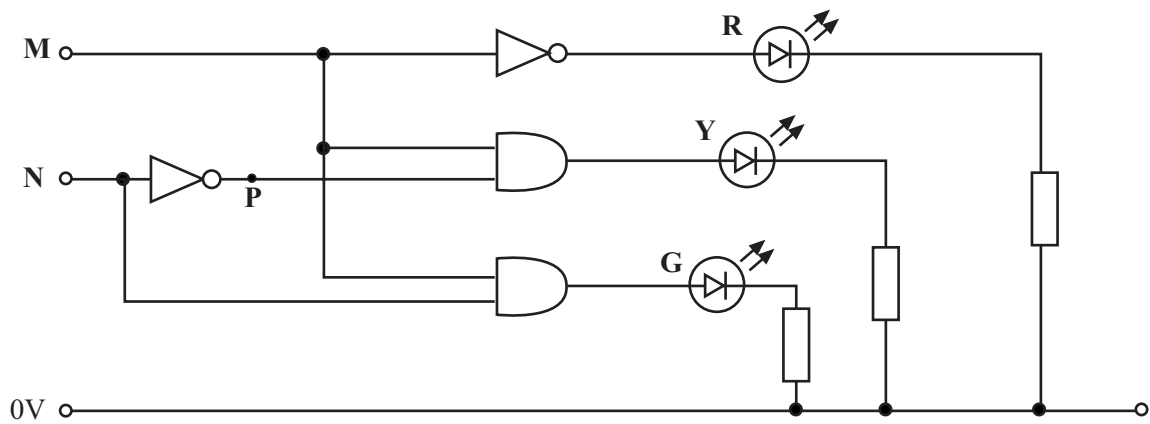

The incomplete truth table for point **P** is given below.

Input M	Input N	Output P
0	0	
0	1	
1	0	
1	1	

8.1 Which are the correct values for output **P**?

A	0	B	0	C	1	D	1
	0		1		0		0
	0		0		1		0
	1		1		0		0

8.2 What must be the logic states of **M** and **N** for the green light to be on?

A $M = 0$ $N = 0$

B $M = 0$ $N = 1$

C $M = 1$ $N = 0$

D $M = 1$ $N = 1$

8.3 What must be the logic states of **M** and **N** for the yellow light to be on?

A $M = 0$ $N = 0$

B $M = 0$ $N = 1$

C $M = 1$ $N = 0$

D $M = 1$ $N = 1$

8.4 What must be the logic states of **M** and **N** for the red light to be on?

A $M = 0$ $N = 0$ or 1

B $M = 1$ $N = 0$ or 1

C $M = 1$ $N = 0$

D $M = 1$ $N = 1$

TURN OVER FOR THE NEXT QUESTION

Turn over ►

QUESTION NINE

An incomplete ray diagram is shown below.

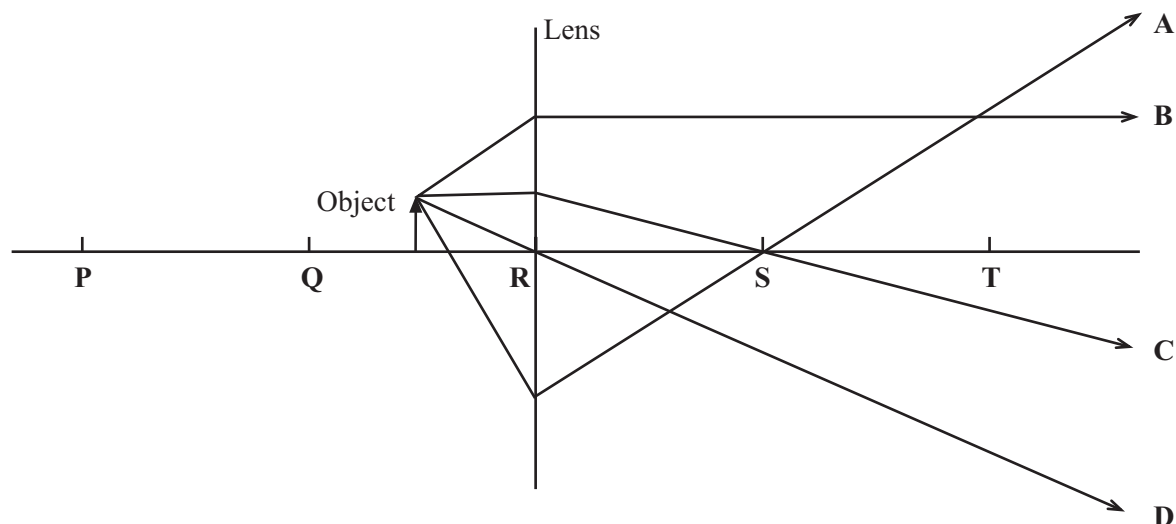

- 9.1 Which ray, **A**, **B**, **C** or **D**, is drawn **incorrectly**?
- 9.2 The image produced is
- A upright and real.
 - B upright and virtual.
 - C upside down and real.
 - D upside down and virtual.
- 9.3 Which of the labelled points is the focus of the lens?
- A P
 - B R
 - C S
 - D T

9.4 The image of the object is formed

- A** between **P** and **Q**.
- B** between **Q** and **R**.
- C** between **R** and **T**.
- D** to the right of **T**.

TURN OVER FOR THE NEXT QUESTION

Turn over ►

QUESTION TEN

A museum has a very valuable gold cup.

A simple alarm system is fitted at the museum.

The cup is in a showcase which stands on a mat. A beam of light shines across the front of the showcase. The beam of light is broken if anyone moves towards the cup.

There are two inputs to the system.

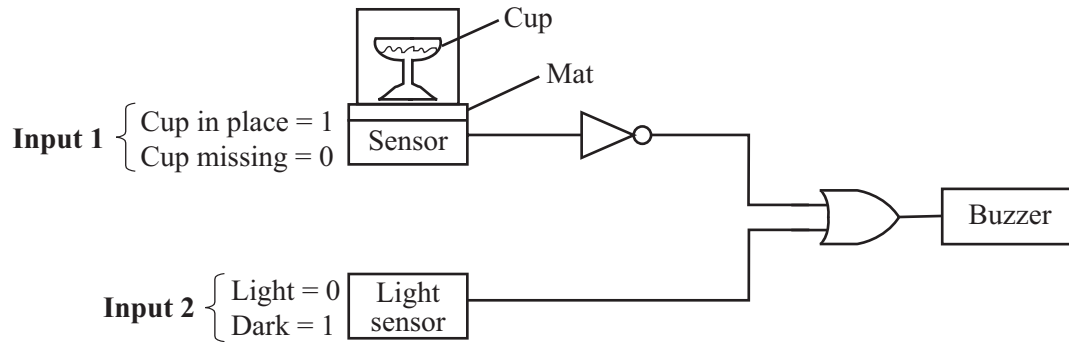

10.1 Which row of the table, **A**, **B**, **C** or **D**, gives the two input sensors?

	Input sensor 1	Input sensor 2
A	moisture switch	LDR
B	pressure switch	LDR
C	LDR	key-operated switch
D	LED	pressure switch

An incomplete truth table for the system is shown below.

Input 1	Input 2	Output
0	0	
0	1	
1	0	
1	1	

10.2 Which column gives the correct values for the output?

A	1	B	0	C	1	D	0
	1		1		0		0
	0		1		0		1
	1		1		0		1

The system needs to be changed so that it can be switched off manually.

The key-operated switch has logic states of: ON (1) and OFF (0).

The output of the original system and the output of the key-operated switch are connected to another logic gate as shown below.

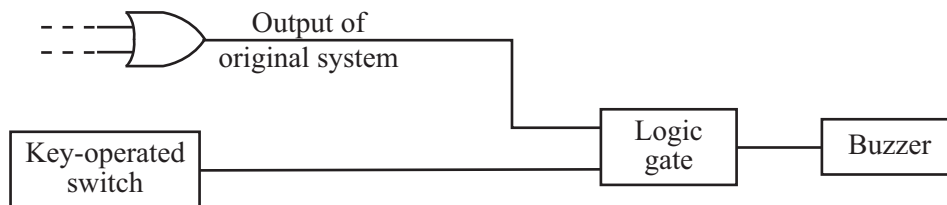

10.3 This extra logic gate is

- A an AND gate.
- B a NOT gate.
- C an OR gate.
- D an AND gate followed by a NOT gate.

10.4 The complete system sounds the buzzer when the key-operated switch

- A is off, the cup is missing, and the light beam is broken.
- B is off, the cup is not missing, and the light beam is broken.
- C is on, and either the cup is missing or the light beam is broken.
- D is on, the cup is not missing, and the light beam is not broken.

END OF TEST

THERE ARE NO QUESTIONS PRINTED ON THIS PAGE

THERE ARE NO QUESTIONS PRINTED ON THIS PAGE

THERE ARE NO QUESTIONS PRINTED ON THIS PAGE