

Surname \_\_\_\_\_

Other Names \_\_\_\_\_

Centre Number \_\_\_\_\_

For Examiner's Use

Candidate Number \_\_\_\_\_

Candidate Signature \_\_\_\_\_

## ASSESSMENT AND QUALIFICATIONS ALLIANCE

General Certificate of Secondary Education

Higher Tier

June 2010

### Physics

Unit Physics P3

Written Paper

**PHY3H**

Friday 28 May 2010 9.00 am

For this paper you must have:

- a ruler.

You may use a calculator.

**TIME ALLOWED**

- 45 minutes plus your additional time allowance.

At the top of the page, write your surname and other names, your centre number, your candidate number and add your signature.

[Turn over]

**BLANK PAGE**

## **INSTRUCTIONS**

- **Use black ink or black ball-point pen.**
- **Answer ALL questions.**
- **You must answer the questions in the spaces provided.**
- **Do all rough work in this book. Cross through any work you do not want to be marked.**

## **INFORMATION**

- **The marks for questions are shown in brackets.**
- **The maximum mark for this paper is 45.**
- **You are expected to use a calculator where appropriate.**
- **You are reminded of the need for good English and clear presentation in your answers.**

## **ADVICE**

- **In all calculations, show clearly how you work out your answer.**

**DO NOT TURN OVER UNTIL TOLD TO DO SO**

Answer ALL questions in the spaces provided.

- 1 (a) A student finds data on the Internet for her project on the Solar System. She checks this data on other websites.

The table shows the checked data.

Name of planet	Diameter in km	Distance from Sun in millions of km	Period in days
Mercury	4 840	58	87
Venus	12 390	108	224
Earth	12 760	149	365
Mars	6 800	228	686
Jupiter	142 800	778	4 332
Saturn	119 400	1 428	10 759
Uranus	47 600	2 870	30 685
Neptune	48 400	4 497	60 190

- 1 (a) (i) In the table, the period of each planet is given in days.

What is meant by the 'period' of a planet?  
[1 mark]

---

- 1 (a) (ii) Suggest why the student checks the data on other websites. [1 mark]

---



---



---

**1 (a) (iii) What is the relationship, if any, between a planet's distance from the Sun and its period? [1 mark]**

---

---

---

**1 (a) (iv) What is the relationship, if any, between a planet's diameter and its period? [1 mark]**

---

---

---

**1 (b) What is the force which provides the centripetal force to keep planets in their orbits? [1 mark]**

---

---

**1 (c) What is the name of the galaxy which contains the Solar System? [1 mark]**

---

---

**[Question 1 continues on the next page]**

- 1 (d) Complete the following sentence by drawing a ring around the correct word in the box.  
[1 mark]

The universe is made up of

hundreds

thousands

millions

billions

of galaxies.

**BLANK PAGE**

**TURN OVER FOR THE NEXT QUESTION**

**2 (a) Read this passage from a health leaflet.**

**Most children can hear the full range of sounds which can be detected by the human ear. But as people get older, they cannot hear the higher frequencies.**

**2 (a) (i) Complete this statement. [1 mark]**

**Most children can detect sounds in the frequency range**

**\_\_\_\_\_ Hz to \_\_\_\_\_ Hz.**

**2 (a) (ii) What word is used to describe sound with a frequency so high that it cannot be heard by humans? [1 mark]**

\_\_\_\_\_



**2 (b) Read this cutting from a newspaper.**

**A shopkeeper has fitted a special loudspeaker outside his store.**

**“We used to have gangs of young people out there,” he said, “but now, when I switch on the special loudspeaker, they hate the sound and go away.”**

**Older people are not bothered by the sound because the frequency is too high for them to hear it.**

**Some people support the use of the special loudspeaker but other people do not.**

**Give ONE reason against its use. [1 mark]**

---

---

---

**2 (c) Machines are often very noisy. They transfer energy, and some of the energy is transformed into sound.**

**What is the cause of the sound? [1 mark]**

---

**[Question 2 continues on the next page]**

- 2 (d) Sound from a machine may damage the hearing of people who work close by. A safety officer measures the sound intensity at different distances from a noisy machine. The average results are shown on the graph.

Average sound intensity in watts per  $\text{m}^2$

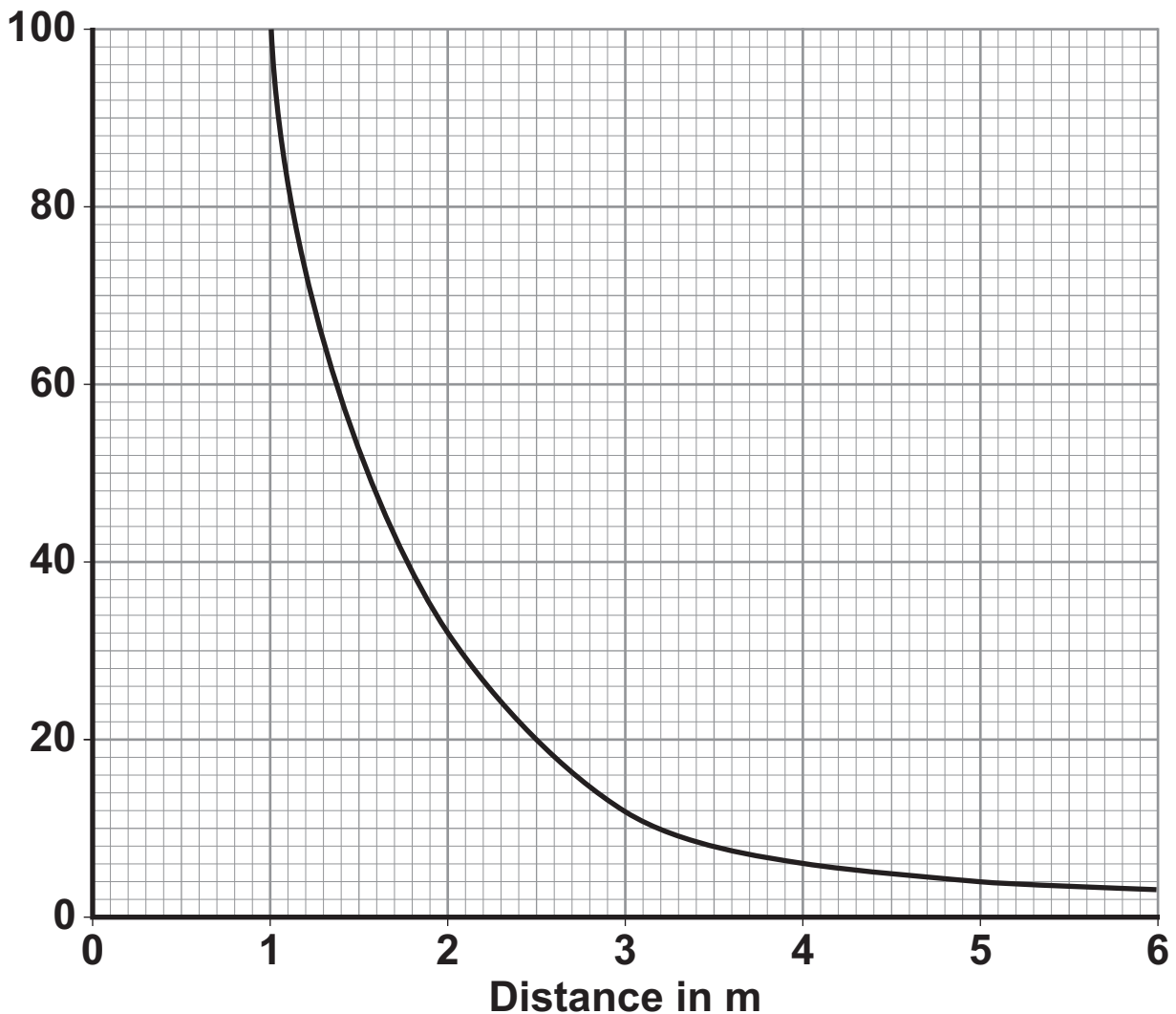

**2 (d) (i) Describe the pattern shown by the graph.  
[2 marks]**

**Use one or more examples from the graph to support your description.**

---

---

---

---

---

---

---

**2 (d) (ii) Average results were plotted.**

**Explain why taking results several times and then calculating average values is more reliable than taking only a single result.  
[2 marks]**

---

---

---

---

---

---

---

**[Turn over]**

- 3 The diagram shows a USB power adapter which plugs into a 230 V a.c. mains socket.

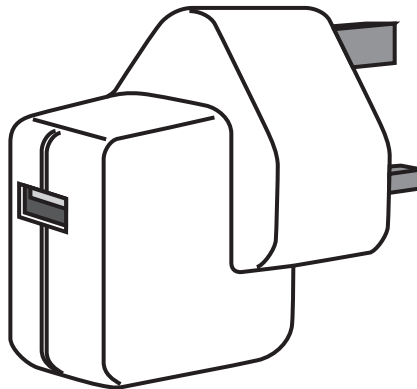

The adapter contains a small step-down transformer.

- 3 (a) The core of the transformer is made of laminated soft iron.

Why is iron used? [1 mark]

---

---

---

- 3 (b) The coils of the transformers are made of insulated copper wire.

Why is the wire insulated? [1 mark]

---

---

---

- 3 (c) There are 500 turns on one coil of the transformer and 20 000 turns on the other coil.

Use the equation in the box to calculate the p.d. across the secondary coil.

$$\frac{\text{p.d. across primary}}{\text{p.d. across secondary}} = \frac{\text{number of turns on primary}}{\text{number of turns on secondary}}$$

Show clearly how you work out your answer and give the unit. [3 marks]

---

---

---

---

p.d. across the secondary = \_\_\_\_\_

[Turn over for the next question]

4 The diagrams show two concrete mixers.

CONCRETE MIXER A

CONCRETE MIXER B

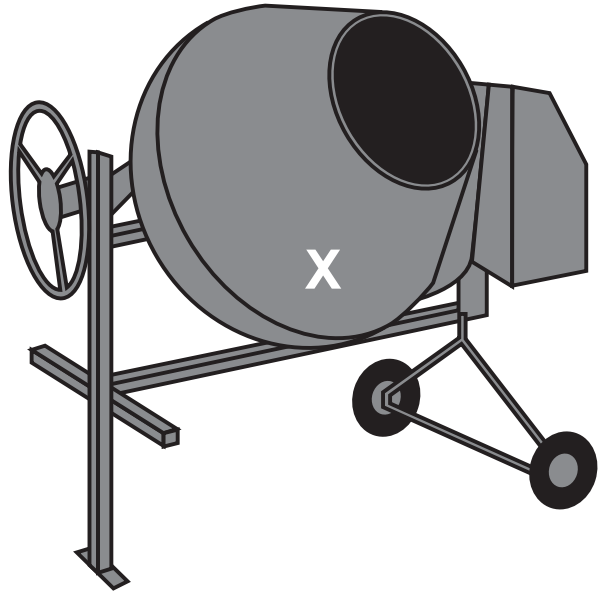
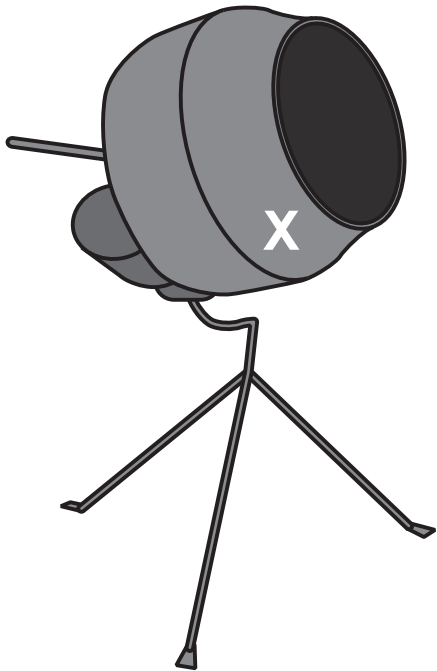

On each diagram, the centre of the white X marks the centre of mass of the concrete mixer and its contents.

4 (a) Complete the sentence to explain what the term 'centre of mass' means. [1 mark]

The centre of mass of a concrete mixer and its contents is \_\_\_\_\_

\_\_\_\_\_

\_\_\_\_\_

\_\_\_\_\_

\_\_\_\_\_

4 (b) Both diagrams are drawn to the same scale.

Concrete mixer B is more stable than concrete mixer A.

The two features which make concrete mixer B more stable are: [2 marks]

1 \_\_\_\_\_  
\_\_\_\_\_  
\_\_\_\_\_

2 \_\_\_\_\_  
\_\_\_\_\_  
\_\_\_\_\_

[Question 4 continues on the next page]

- 4(c) Use the terms 'line of action of the weight' and 'resultant moment' to explain why a stable concrete mixer does not fall over when it is given a small push. [2 marks]

---

---

---

---

---

---

---

---

---

---



**BLANK PAGE**

**TURN OVER FOR THE NEXT QUESTION**

5(a) A laboratory technician sets up a demonstration.

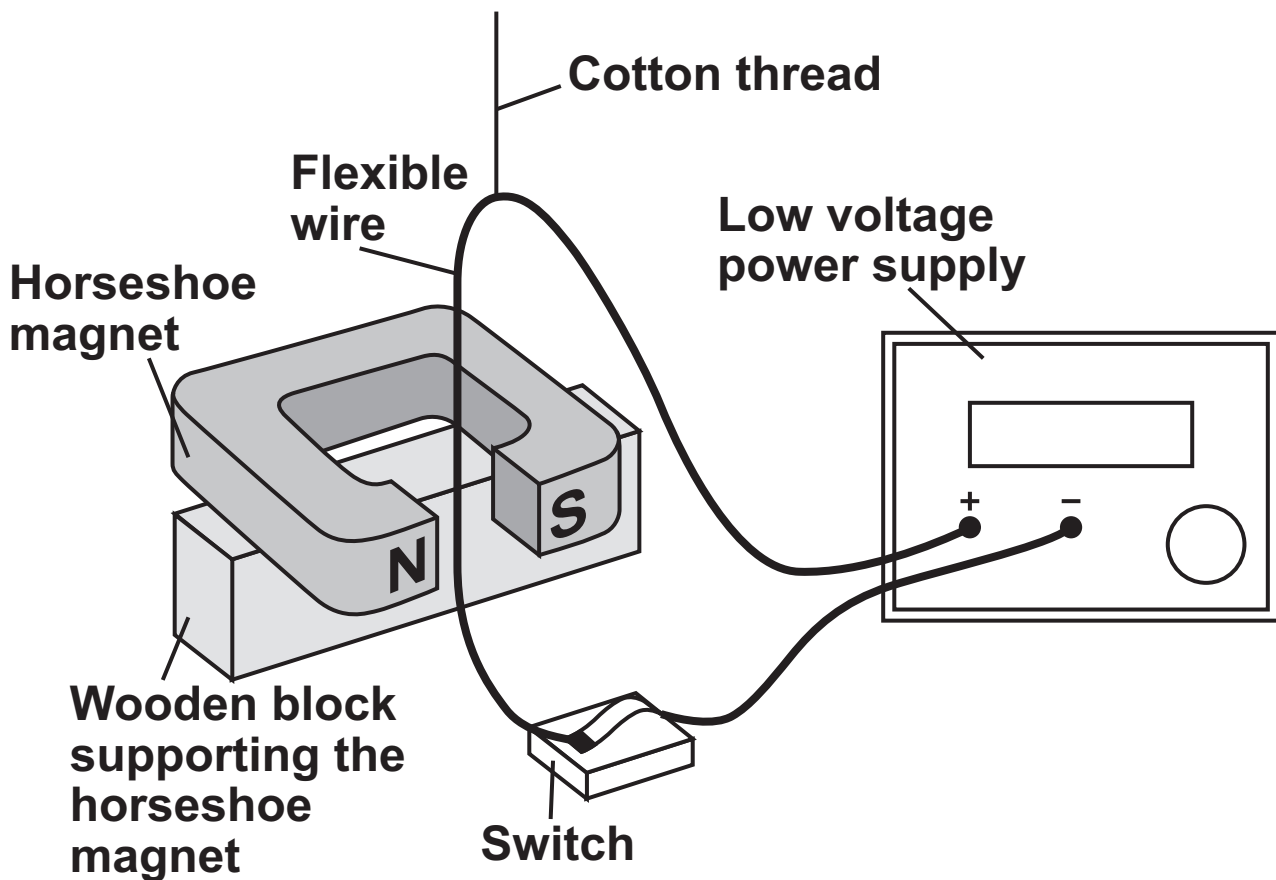

A flexible wire is suspended between the ends of a horseshoe magnet. The flexible wire hangs from a cotton thread. When the switch is closed, the wire kicks forward.

Identify the effect which is being demonstrated. [1 mark]

5(b) A teacher makes some changes to the set-up of the demonstration.

What effect, if any, will each of the following changes have?

**5 (b) (i) A more powerful horseshoe magnet is used. [1 mark]**

---

---

---

**5 (b) (ii) The connections to the power supply are reversed. [1 mark]**

---

---

---

3
---

**[Turn over for the next question]**

- 6 The diagram shows a design for a crane. The crane is controlled by a computer.

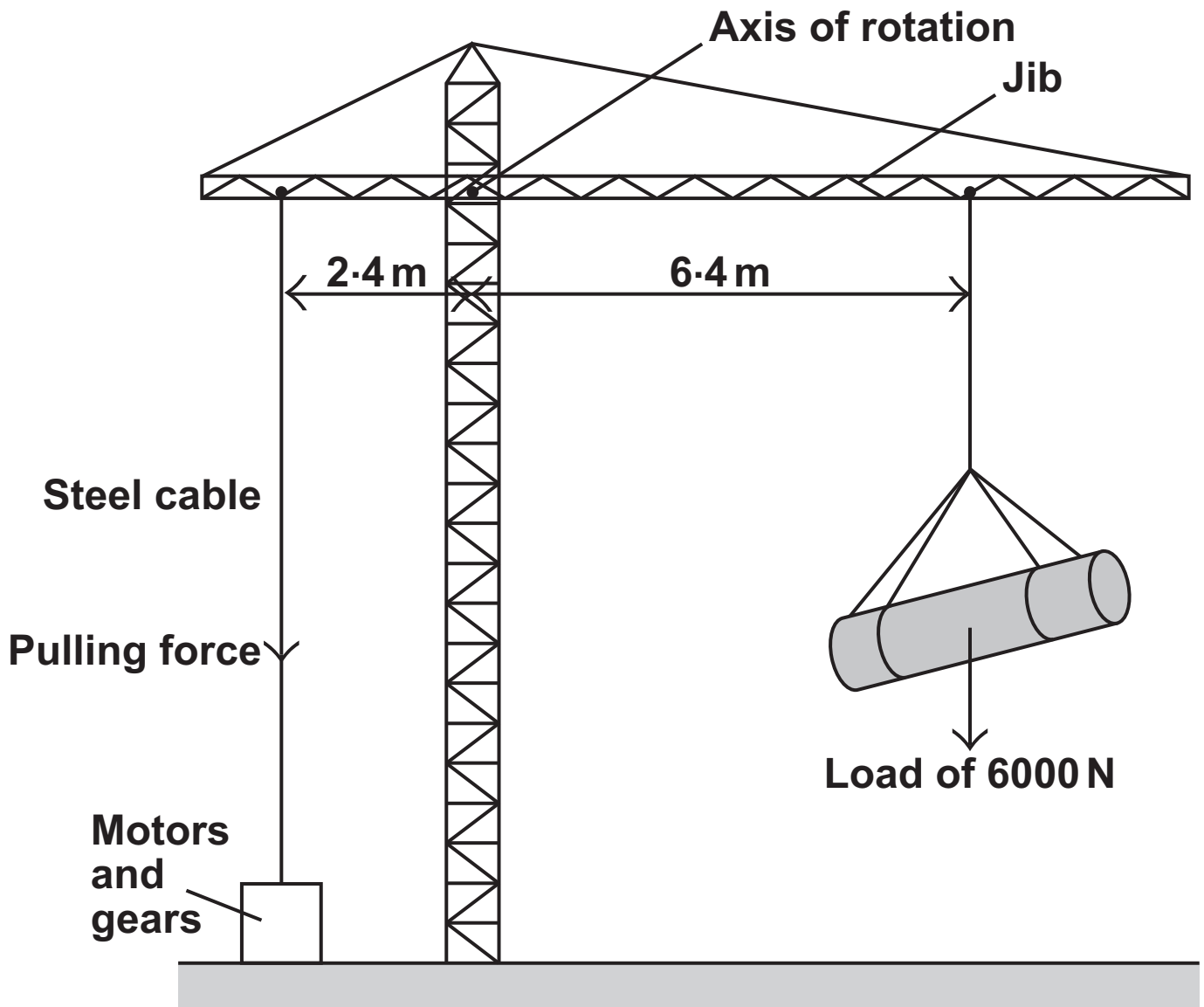

The purpose of the motors and gears is to change the pulling force in the steel cable. This is done so that the jib stays horizontal whatever the size of the load or the position of the load.

Use the equation to answer questions (a) and (b).

$$\text{moment} = \text{force} \times \begin{matrix} \text{perpendicular distance from the} \\ \text{line of action of the force to the} \\ \text{axis of rotation} \end{matrix}$$

6 (a) Calculate the moment caused by the load in the position shown in the diagram. [3 marks]

Show clearly how you work out your answer and give the unit.

---

---

---

Moment = \_\_\_\_\_

6 (b) Calculate the pulling force that is needed in the steel cable to keep the jib horizontal. [2 marks]

Show clearly how you work out your answer.

---

---

---

Pulling force = \_\_\_\_\_ N

- 7 A student investigated how the nature of the image depends on the position of the object in front of a large converging lens.

The diagram shows one position for the object.

- 7 (a) Use a ruler to complete a ray diagram to show how the image of the object is formed.  
[4 marks]

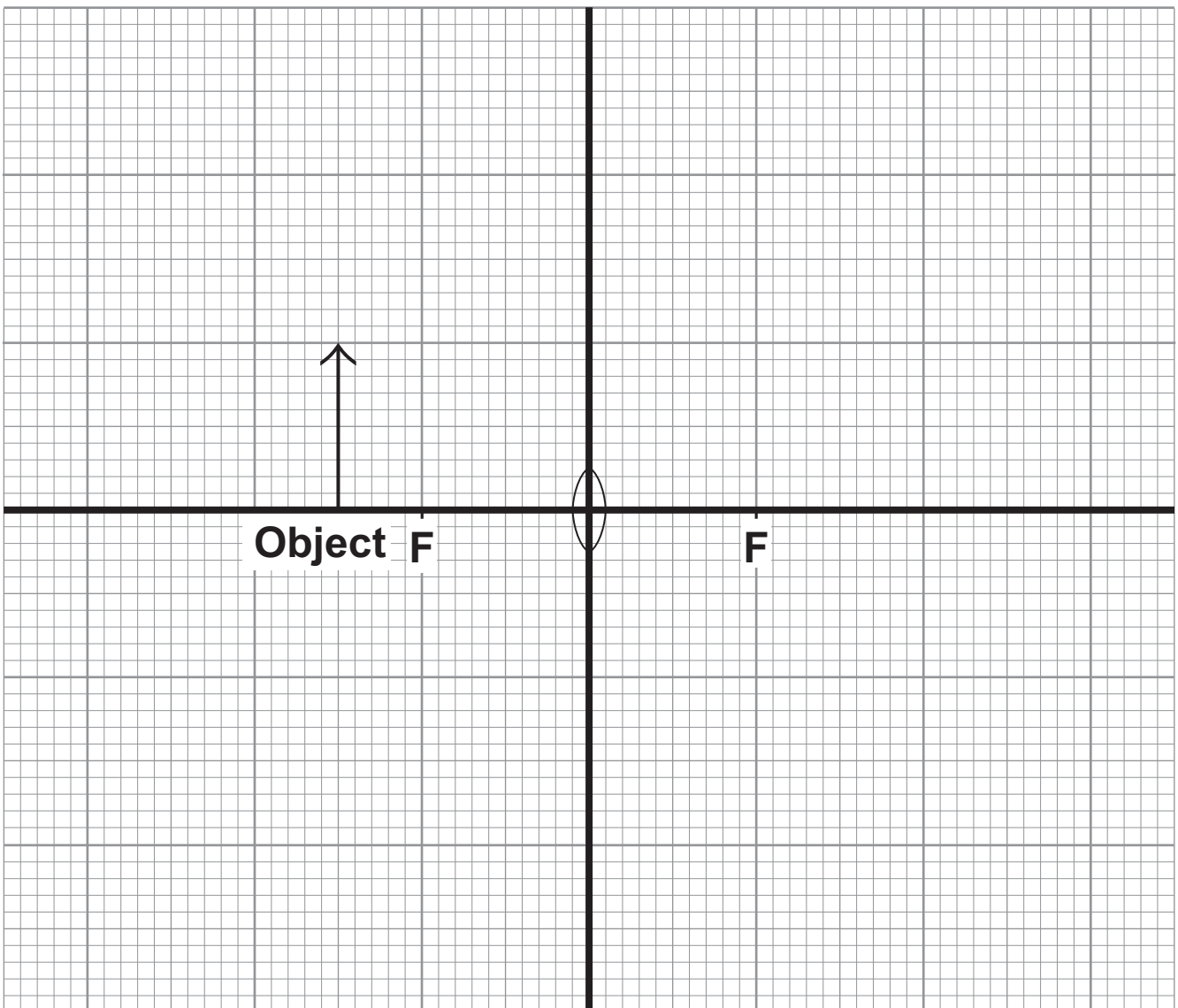

**KEY:**

**F = principal focus**

7 (b) Describe the nature of this image relative to the object. [2 marks]

---

---

---

---

6
---

[Turn over for the next question]

**8 Every star goes through a 'life cycle'.**

**8 (a) Describe how a star forms. [2 marks]**

---

---

---

---

---

---

---

---

**8 (b) During a long period of its life, a star remains in a stable state.**

**Explain why a star remains stable. [2 marks]**

---

---

---

---

---

---

---

---



8 (c) Some stars are much more massive than the Sun.

Describe what will happen to a star, originally much more massive than the Sun, after it reaches its red giant stage. [2 marks]

---

---

---

---

---

---

---

---

6
---

END OF QUESTIONS

**BLANK PAGE**

**BLANK PAGE**

For Examiner's Use	
Examiner's Initials	
Question	Mark
1	
2	
3	
4	
5	
6	
7	
8	
TOTAL	

**BLANK PAGE**