

Surname		Other Names	
Centre Number		Candidate Number	
Candidate Signature			

For Examiner's Use

General Certificate of Secondary Education
June 2008

ADDITIONAL SCIENCE
Unit Physics P2

PHYSICS
Unit Physics P2

Foundation Tier

Wednesday 11 June 2008 1.30 pm to 2.15 pm

<p>For this paper you must have:</p> <ul style="list-style-type: none"> a ruler. <p>You may use a calculator.</p>

Time allowed: 45 minutes

Instructions

- Use black ink or black ball-point pen.
- Fill in the boxes at the top of this page.
- Answer **all** questions.
- You must answer the questions in the spaces provided. Answers written in margins or on blank pages will not be marked.
- Do all rough work in this book. Cross through any work you do not want to be marked.

Information

- The maximum mark for this paper is 45.
- The marks for questions are shown in brackets.
- You are expected to use a calculator where appropriate.
- You are reminded of the need for good English and clear presentation in your answers.

Advice

- In all calculations, show clearly how you work out your answer.

PHY2F
F



For Examiner's Use			
Question	Mark	Question	Mark
1		5	
2		6	
3			
4			
Total (Column 1) →			
Total (Column 2) →			
TOTAL			
Examiner's Initials			



J U N 0 8 P H Y 2 F 0 1

There are no questions printed on this page

**DO NOT WRITE ON THIS PAGE
ANSWER IN THE SPACES PROVIDED**



Answer **all** questions in the spaces provided.

- 1 (a) A car driver makes an emergency stop.

The chart shows the ‘thinking distance’ and the ‘braking distance’ needed to stop the car.



Calculate the total stopping distance of the car.

.....

Stopping distance = m
(1 mark)

- 1 (b) The graph shows how the braking distance of a car driven on a dry road changes with the car's speed.

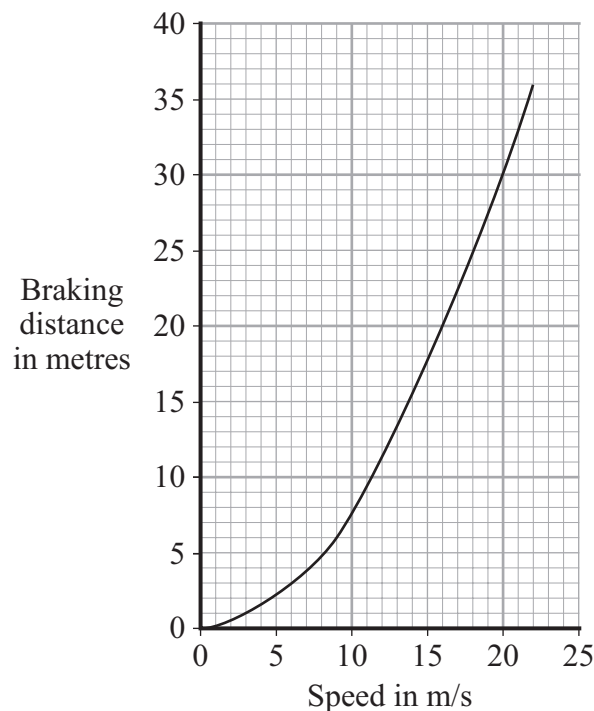

The braking distance of the car on an icy road is longer than the braking distance of the car on a dry road.

- 1 (b) (i) Draw a new line on the graph to show how the braking distance of the car on an icy road changes with speed.

(2 marks)

Question 1 continues on the next page

Turn over ►



- 1 (b) (ii) Which **two** of the following would also increase the braking distance of the car?

Put a tick (✓) in the box next to each of your answers.

rain on the road

the driver having drunk alcohol

car brakes in bad condition

the driver having taken drugs

(2 marks)

- 1 (c) The thinking distance depends on the driver's reaction time.

The table shows the reaction times of three people driving under different conditions.

Car driver	Condition	Reaction time in seconds
A	Wide awake with no distractions	0.7
B	Using a hands-free mobile phone	0.9
C	Very tired and listening to music	1.2

The graph lines show how the thinking distance for the three drivers, **A**, **B** and **C**, depends on how fast they are driving the car.

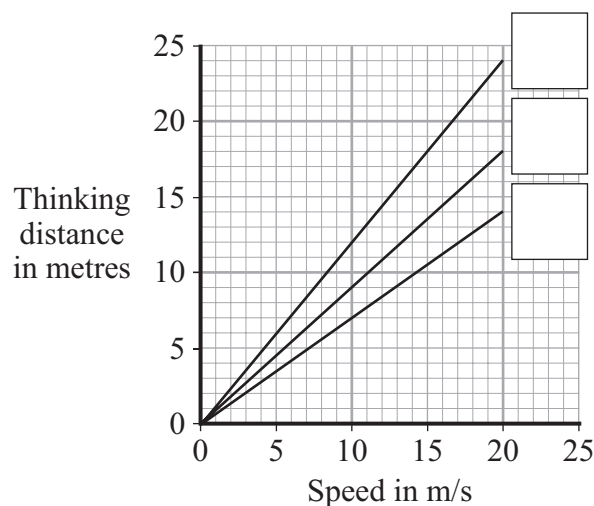

- 1 (c) (i) Match each graph line to the correct driver by writing **A**, **B** or **C** in the box next to the correct line.

(2 marks)



1 (c) (ii) The information in the table cannot be used to tell if driver C's reaction time is increased by being tired **or** by listening to music.

Explain why.

.....

.....

.....

.....

(2 marks)

9

Turn over for the next question

Turn over ►



- 2 (a) A student rubs a nylon comb on the sleeve of his jumper.

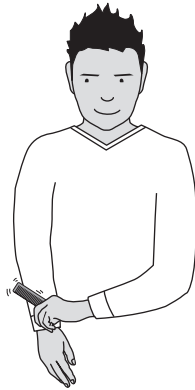

- 2 (a) (i) Use words from the box to complete the following sentence.

electrons	hand	jumper	protons
------------------	-------------	---------------	----------------

The comb becomes negatively charged because move
from the student's to the comb.

(2 marks)

- 2 (a) (ii) What type of charge is left on the jumper?

.....

(1 mark)

- 2 (a) (iii) The negatively charged comb is placed close to a charged plastic ruler. The comb and the ruler attract each other.

Complete the following sentence by drawing a ring around the correct line in the box.

The ruler is

negatively charged
positively charged
uncharged

.

(1 mark)



- 2 (b) Electrostatic charge can damage computer chips. People working with computer chips may wear a special bracelet, with a wire joining the bracelet to earth (the earth wire). Any negative charge on the person will flow through the wire to earth.

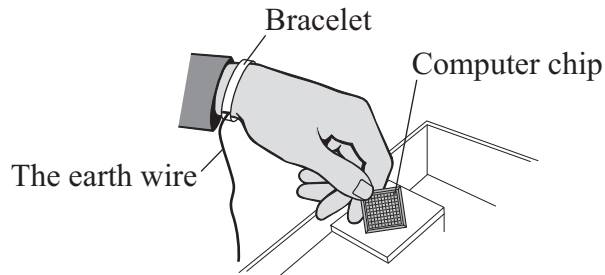

- 2 (b) (i) Which **one** of the following materials should the bracelet be made from?

Draw a ring around your answer.

copper **plastic** **rubber**

Give a reason for your answer.

.....

(2 marks)

- 2 (b) (ii) Which **one** of the following words is used to describe the rate of flow of charge through a wire?

Draw a ring around your answer.

current **resistance** **voltage**

(1 mark)

7

Turn over for the next question

Turn over ►



- 3 (a) The diagram shows the inside of a correctly wired three-pin plug.

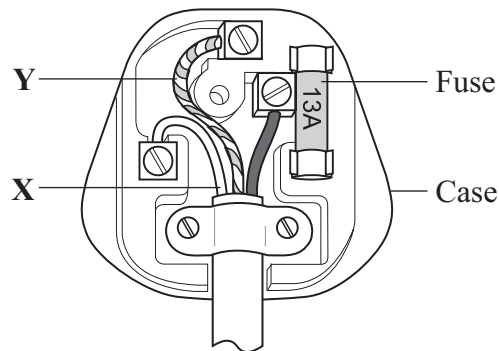

- 3 (a) (i) What colour is the insulation on the wire labelled X?

Draw a ring around your answer.

blue brown green/yellow

(1 mark)

- 3 (a) (ii) What name is given to the wire labelled Y?

Draw a ring around your answer.

earth live neutral

(1 mark)

- 3 (a) (iii) What material would be suitable for the case of the plug?

.....
(1 mark)

- 3 (a) (iv) Which **one** of the following is the correct circuit symbol for a fuse?

Draw a ring around your answer.

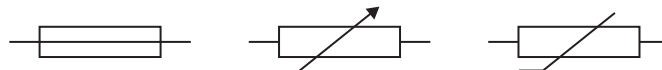

(1 mark)



- 3 (b) A householder does not have enough electric sockets in the kitchen. To overcome the problem, the householder uses two adaptors to plug five appliances into a single electric socket.

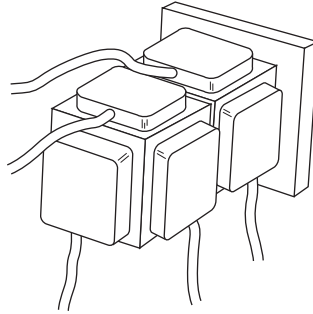

Explain why this is dangerous.

.....

.....

.....

.....

(2 marks)

6

Turn over for the next question

Turn over ►



- 4 The diagram shows the forces on a small, radio-controlled, flying toy.

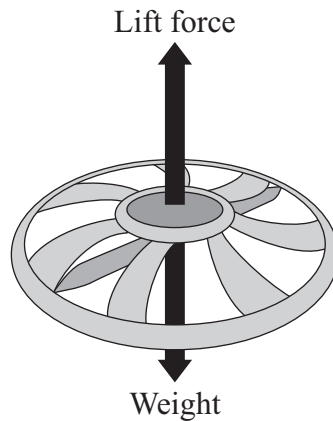

- 4 (a) (i) The mass of the toy is 0.06 kg.
Gravitational field strength = 10 N/kg

Use the equation in the box to calculate the weight of the toy.

$$\text{weight} = \text{mass} \times \text{gravitational field strength}$$

Show clearly how you work out your answer and give the unit.

.....
.....

Weight =
(3 marks)

- 4 (a) (ii) Complete the following sentence by drawing a ring around the correct line in the box.

When the toy is hovering stationary in mid-air, the lift force is

bigger than
 the same as
 smaller than

the weight of the toy.

(1 mark)



4 (b) When the motor inside the toy is switched off, the toy starts to *accelerate* downwards.

4 (b) (i) What does the word *accelerate* mean?

.....
(1 mark)

4 (b) (ii) What is the direction of the resultant force on the falling toy?

.....
(1 mark)

4 (b) (iii) Does the momentum of the toy increase, decrease or stay the same?

.....

Give a reason for your answer.

.....
(2 marks)

8

Turn over for the next question

Turn over ►



- 5 (a) The circuit diagram drawn below includes a component labelled **X**.

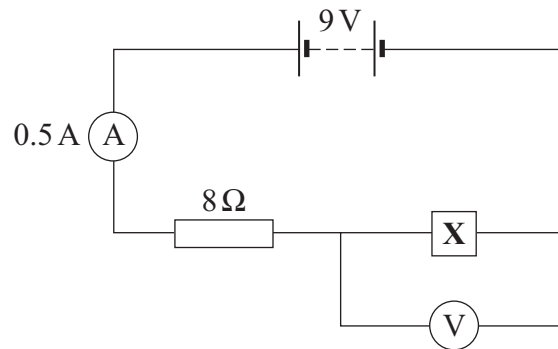

- 5 (a) (i) Use the equation in the box to calculate the potential difference across the 8 ohm resistor.

potential difference = current \times resistance

Show clearly how you work out your answer.

.....

Potential difference = volts
 (2 marks)

- 5 (a) (ii) What is the potential difference across component **X**?

.....
 (1 mark)



5 (b) The graph shows how the resistance of component X changes with temperature.

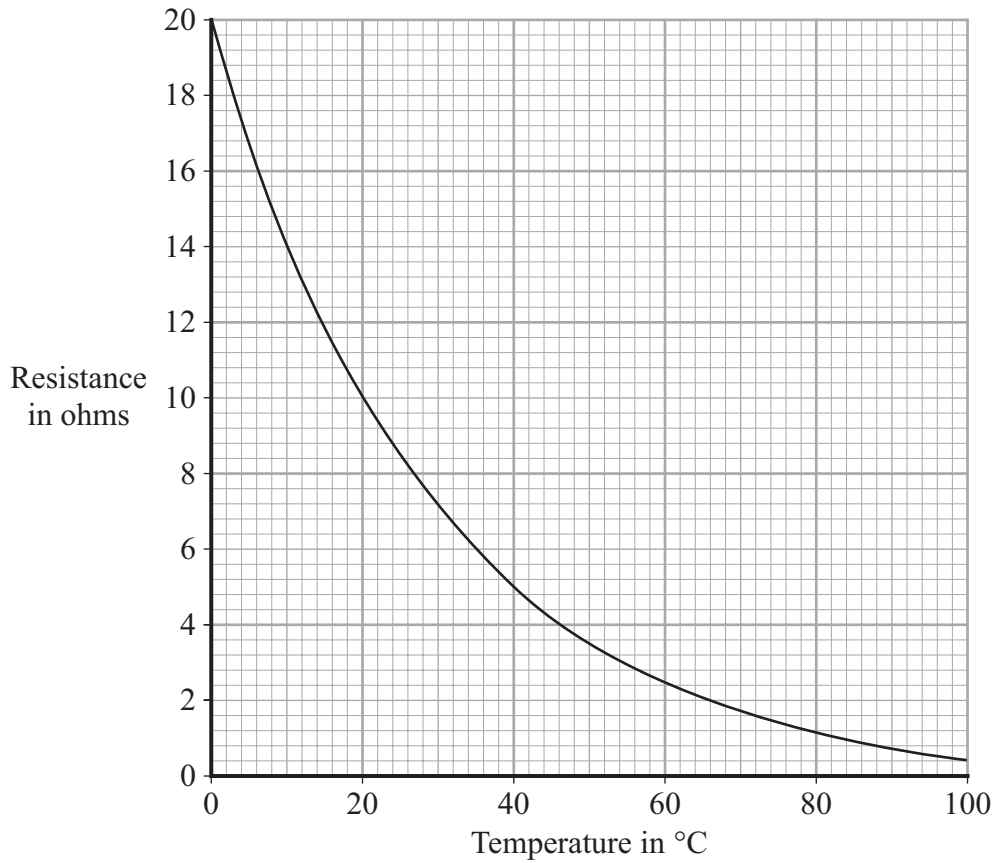

5 (b) (i) What is component X?

.....

(1 mark)

5 (b) (ii) Over which range of temperatures does the resistance of component X change the most?

Put a tick (✓) in the box next to your choice.

0°C to 20°C

20°C to 40°C

40°C to 60°C

60°C to 80°C

80°C to 100°C

(1 mark)

5

Turn over ►



- 6 (a) The table gives information about the radioactive isotope, radon-222.

mass number	222
atomic number	86
radiation emitted	alpha particle

- 6 (a) (i) Complete the following sentence.

The mass number is the total number of..... and
..... inside an atom.

(2 marks)

- 6 (a) (ii) Radon-222 is an isotope of radon.

How many protons are there in an atom of radon-222?

.....

(1 mark)

- 6 (a) (iii) When an atom of radon-222 emits an alpha particle, the radon-222 changes into an atom of polonium-218.

An alpha particle consists of 2 protons and 2 neutrons.

How is the structure of the nucleus of a polonium-218 atom different from the structure of the nucleus of a radon-222 atom?

.....

(1 mark)

- 6 (b) The pie chart shows the average radiation dose that a person in the UK receives each year from natural background radiation. The doses are measured in millisieverts (mSv).

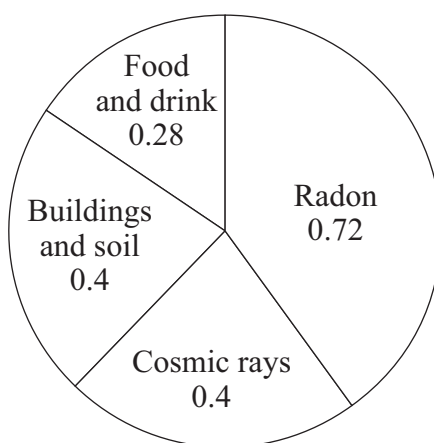

- 6 (b) (i) Calculate the proportion of natural background radiation that comes from radon. Show clearly how you work out your answer.

.....

.....

Proportion of radon =
(2 marks)

- 6 (b) (ii) Not all background radiation is from natural sources.

Name **one** source of background radiation that is not natural.

.....
(1 mark)

- 6 (c) The bar chart shows the average yearly dose from natural background radiation in different European countries.

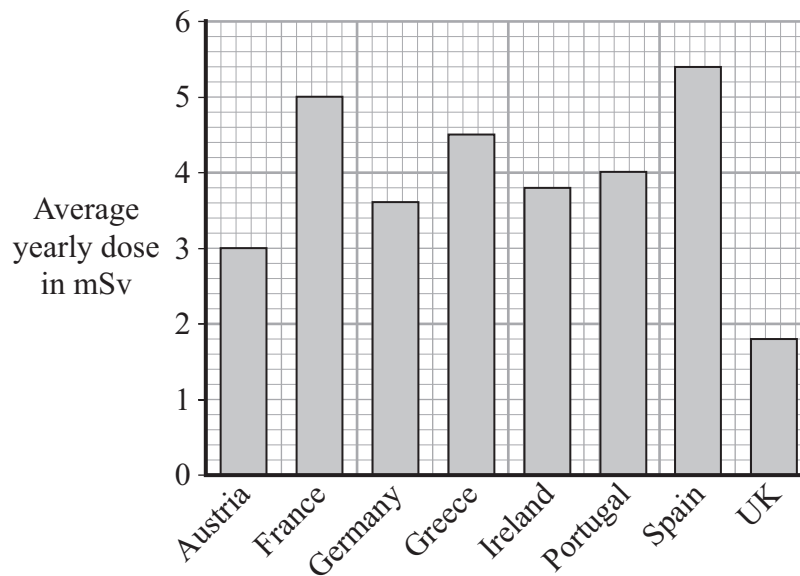

- 6 (c) (i) How many times bigger is the average annual background dose in Germany compared to the UK?

.....
(1 mark)

Question 6 continues on the next page

Turn over ►



- 6 (c) (ii) The following table gives the effects of different radiation doses on the human body.

Radiation dose in mSv	Effects
10 000	Immediate illness; death within a few weeks
1 000	Radiation sickness; unlikely to cause death
50	Lowest dose with evidence of causing cancer

A family goes to Germany for a two-week holiday. Should they be concerned about the higher level of background radiation in Germany?

Draw a ring around your answer.

Yes No

Explain your answer.

.....

.....

.....

.....

(2 marks)

10

END OF QUESTIONS

