

Please write clearly in block capitals.

Centre number

--	--	--	--	--

Candidate number

--	--	--	--

Surname

Forename(s)

Candidate signature

GCSE PHYSICS

F

Foundation Tier Unit Physics P3

Friday 17 June 2016

Morning

Time allowed: 1 hour

Materials

For this paper you must have:

- a ruler
- a calculator
- the Physics Equations Sheet (enclosed).

Instructions

- Use black ink or black ball-point pen.
- Fill in the boxes at the top of this page.
- Answer **all** questions.
- You must answer the questions in the spaces provided. Do not write outside the box around each page or on blank pages.
- Do all rough work in this book. Cross through any work you do not want to be marked.

Information

- The marks for questions are shown in brackets.
- The maximum mark for this paper is 60.
- You are expected to use a calculator where appropriate.
- You are reminded of the need for good English and clear presentation in your answers.
- Question 8(b) should be answered in continuous prose.
In this question you will be marked on your ability to:
 - use good English
 - organise information clearly
 - use specialist vocabulary where appropriate.

Advice

- In all calculations, show clearly how you work out your answer.
-



Answer **all** questions in the spaces provided.

1 **Figure 1** is a diagram of a human eye.

Three of the parts of the eye are labelled **P**, **Q** and **R**.

Figure 1

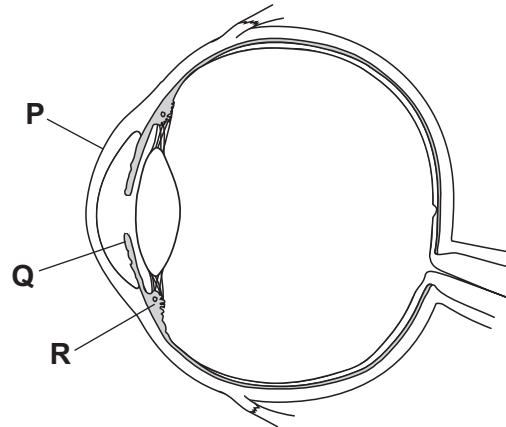

1 (a) Draw **one** line from each box, **P**, **Q** and **R**, to the correct part of the eye.

[3 marks]

Label

Part of the eye

P

Ciliary muscles

Q

Cornea

R

Iris

Retina

1 (b) What is the function of the pupil?

[1 mark]



1 (c) As people get older, the near point of their vision changes.

What does 'the near point' mean?

[1 mark]

Tick (✓) **one** box.

The closest distance to the eye that an object can be clearly seen

The distance between the front and back of the eyeball

The focal length of the lens in the eye

1 (d) How does the eye change in order to focus on objects at different distances?

[1 mark]

Tick (✓) **one** box.

The distance between the lens and the retina changes

The eyeball changes shape

The lens changes shape

1 (e) In laser eye surgery, the cornea is reshaped to help improve a person's vision.

Complete the following sentence.

[1 mark]

Surgeons use the _____ transferred by the light from a laser to cut and reshape the cornea.

1 (f) Lasers were tested on animals before they were used in surgery on people.

Suggest why some people disagree with testing lasers on animals.

[1 mark]

Turn over ►



2 **Figure 2** shows an X-ray of an arm with a broken bone.

Figure 2



2 (a) Complete the following sentence.

[1 mark]

X-rays are part of the _____ spectrum.

2 (b) **Figure 3** shows how the intensity of the X-rays changes as they pass through soft tissue and reach a detector.

Figure 3

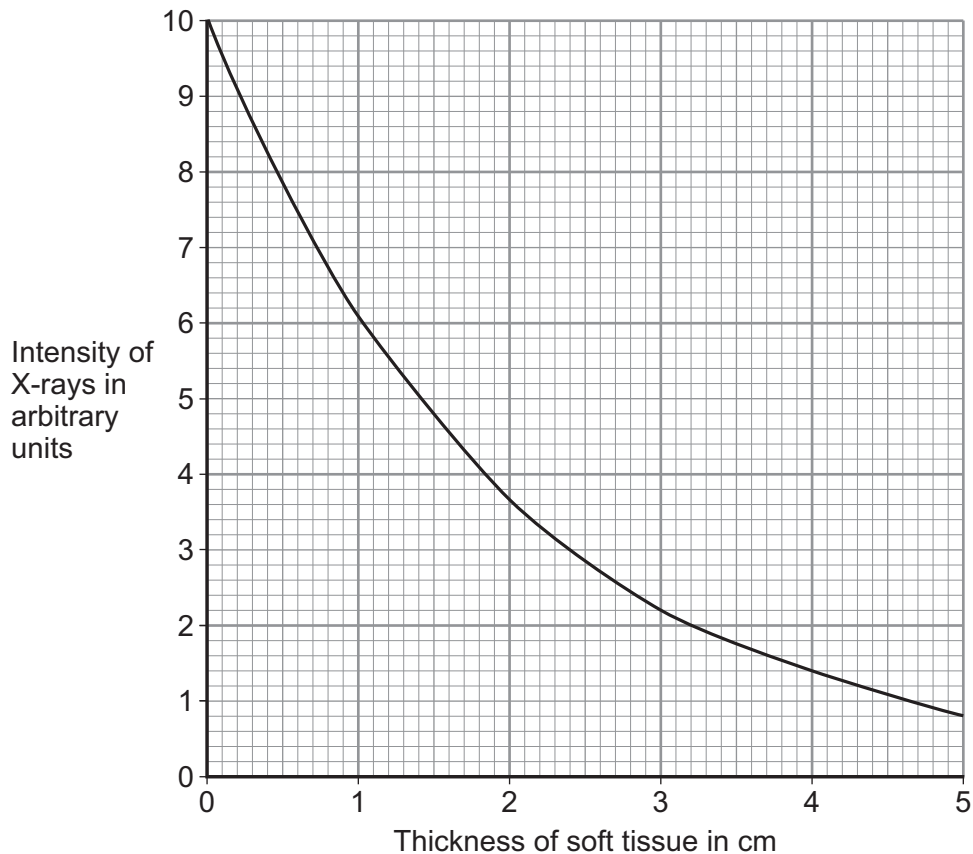

- 2 (b) (i)** Use **Figure 3** to determine the intensity of X-rays reaching the detector for a 3 cm thickness of soft tissue.

[1 mark]

Intensity of X-rays = _____ arbitrary units

- 2 (b) (ii)** Describe how the thickness of soft tissue affects the intensity of the X-rays.

[2 marks]

- 2 (b) (iii)** The data in **Figure 3** are shown as a line graph and not as a bar chart.

Choose the reason why.

[1 mark]

Tick (✓) **one** box.

Both variables are categoric

Both variables are continuous

One variable is continuous and one is categoric

- 2 (c)** What happens to X-rays when they enter a bone?

[1 mark]

Question 2 continues on the next page

Turn over ►



2 (d) How are images formed electronically in a modern X-ray machine?

[1 mark]

Tick (✓) **one** box.

With a charge-coupled device (CCD)

With an oscilloscope

With photographic film

2 (e) Radiographers who take X-ray photographs may be exposed to X-rays.

2 (e) (i) X-rays can increase the risk of the radiographer getting cancer.

Why can X-rays increase the risk of getting cancer?

[1 mark]

Tick (✓) **one** box.

X-rays travel at the speed of light

X-rays can travel through a vacuum

X-rays are ionising

2 (e) (ii) What should the radiographer do to reduce the risk from X-rays?

[1 mark]



Turn over for the next question

**DO NOT WRITE ON THIS PAGE
ANSWER IN THE SPACES PROVIDED**

Turn over ►



0 7

3 **Figure 4** is a simplified diagram of a hydraulic brake system.

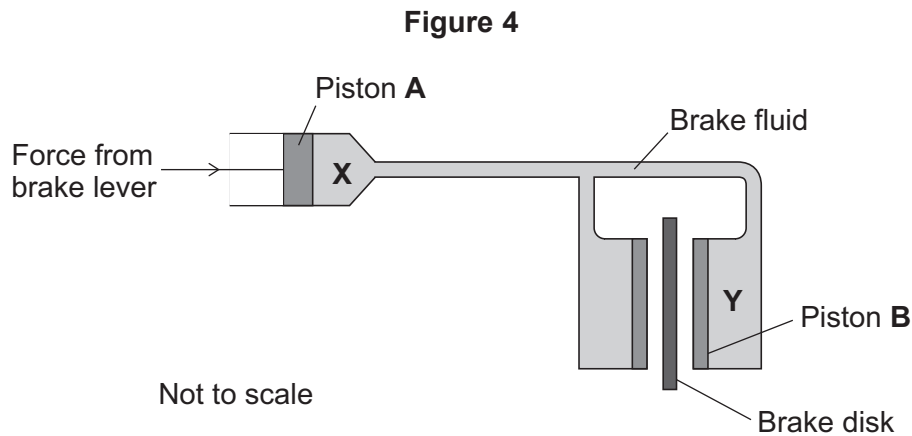

3 (a) Which is the correct statement about the pressure at **X** and the pressure at **Y**?

[1 mark]

Tick (✓) **one** box.

The pressure at **X** is greater than at **Y**

The pressure at **X** is the same as at **Y**

The pressure at **X** is less than at **Y**

3 (b) Piston **B** is larger than piston **A**.

How will this affect the size of the force on piston **B**?

Use the correct answer from the box to complete the sentence.

[1 mark]

smaller than

the same as

larger than

The force on piston **B** will be _____ the force on piston **A**.



3 (c) (i) A force of 24 N acts on piston **A**. The cross-sectional area of piston **A** is 8 mm².

Calculate the pressure in N/mm² at position **X**.

Use the correct equation from the Physics Equations Sheet.

[2 marks]

Pressure = _____ N/mm²

3 (c) (ii) The unit N/mm² is not often used to measure pressure.

Which unit is usually used to measure pressure?

[1 mark]

Tick (✓) **one** box.

newton

pascal

watt

3 (d) The liquid used in the hydraulic brake system freezes at –30 °C.

Suggest **one** effect a temperature below –30 °C would have on the brake system.

[1 mark]

6

Turn over ►



- 4 A sign hangs from the ceiling using two cables, as shown in **Figure 5**.

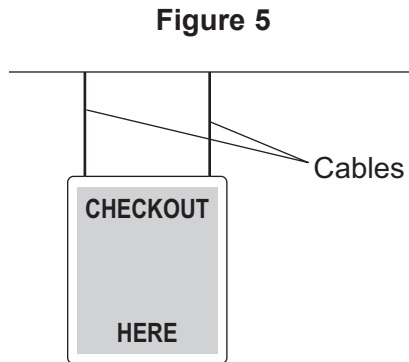

- 4 (a) On **Figure 5**, mark the centre of mass of the sign using an X.

[1 mark]

- 4 (b) Use the correct answer from the box to complete the sentence.

[1 mark]

concentrated	greatest	pivoted
--------------	----------	---------

The centre of mass of an object is the point where the mass appears to be _____ .

- 4 (c) A breeze made the sign swing forwards and backwards like a pendulum. The frequency of oscillations of the sign was 2 hertz.

Calculate the periodic time for the sign.

Use the correct equation from the Physics Equations Sheet.

[2 marks]

Periodic time = _____ seconds



- 4 (d) **Figure 6** is a sketch graph showing how the frequency of the oscillations of a pendulum changes as the length of the pendulum is increased.

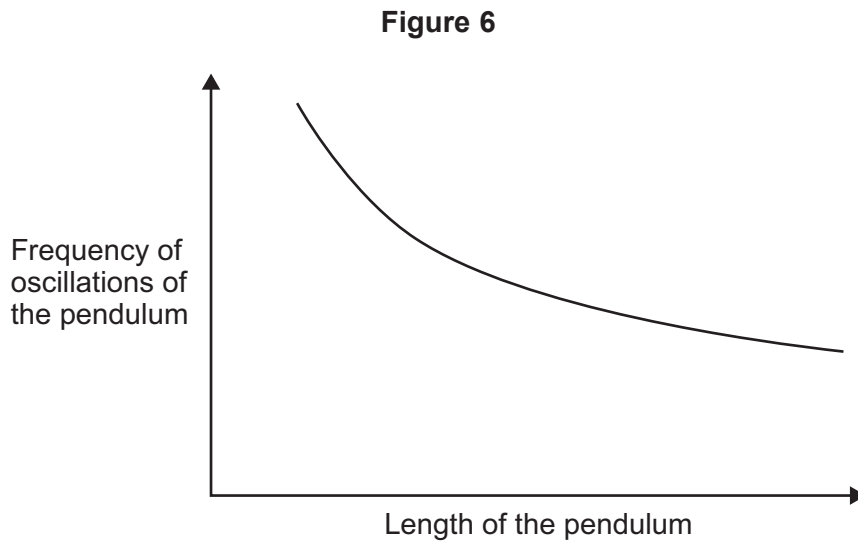

Give **one** way the sign could be made to swing with a lower frequency. Use **only** the information in the sketch graph.

[1 mark]

5

Turn over for the next question

Turn over ►



5 (a) Ultrasound is sound above the maximum frequency that humans can hear.

What is the maximum frequency that most humans can hear?

[1 mark]

Tick (✓) **one** box.

20 Hz

2000 Hz

20 000 Hz

5 (b) **Figure 7** shows a submerged submarine.

Figure 7

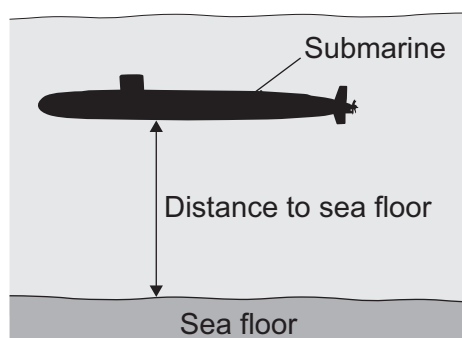

Not to scale

The submarine sends a pulse of ultrasound to the sea floor.
The pulse takes 0.25 seconds to travel from the submarine to the sea floor.

The speed of sound in water is 1600 m/s.

Calculate the distance from the submarine to the sea floor.

Use the correct equation from the Physics Equations Sheet.

[2 marks]

Distance = _____ m



- 5 (c)** The ultrasound is reflected from the sea floor back to the submarine.
Use the correct answer from the box to complete the sentence.

[1 mark]

half	the same as	twice
------	-------------	-------

The total distance the ultrasound pulse travelled is _____ the distance to the sea floor.

- 5 (d)** The submarine moves through the sea and every few seconds sends a pulse of ultrasound to check the distance to the sea floor.

Table 1 shows the time taken for five ultrasound pulses to travel from the submarine to the sea floor and back to the submarine.

Table 1

Pulse number	Time for pulse to return in seconds
1	0.50
2	0.45
3	0.38
4	0.40
5	0.48

Describe how the distance from the submarine to the sea floor changed over these five pulses.

[2 marks]

Turn over ►



- 6 A drum is hit by a beater attached to a drumstick lever. The drumstick lever is attached to a foot-pedal by a chain, as shown in **Figure 8**.

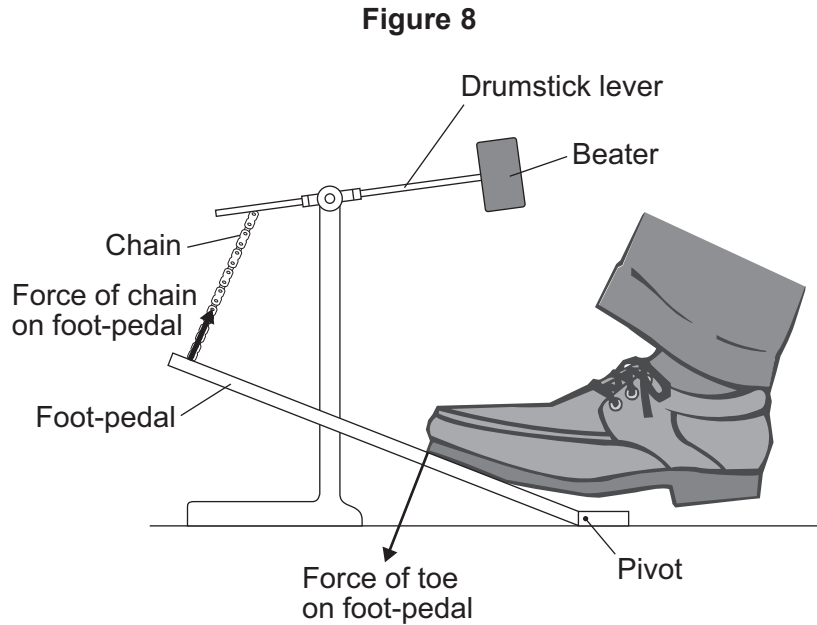

- 6 (a) State how the size of the force of the chain on the foot-pedal compares with the size of the force of the toe on the foot-pedal.

[1 mark]

- 6 (b) The foot-pedal is pushed halfway down and held stationary.

The force of the toe and the force of the chain each create a moment which acts on the foot-pedal.

Compare the size and direction of the moments of the toe and the chain.

[1 mark]

Tick (✓) **one** box.

Size	Direction	Tick (✓)
The moments are equal	same	<input type="checkbox"/>
The moments are equal	opposite	<input type="checkbox"/>
The moment of the force of the toe is greater	same	<input type="checkbox"/>



6 (c) How can the drummer create a greater moment about the pivot without increasing the force he applies?

[1 mark]

3

Turn over for the next question

Turn over ►



- 7 An endoscope is a piece of equipment used by doctors. An endoscope contains optical fibres. **Figure 9** shows an endoscope.

Figure 9

Tube containing
optical fibres

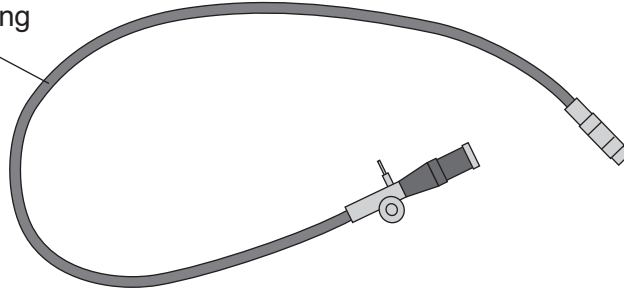

- 7 (a) State what a doctor would use an endoscope for.

[1 mark]

- 7 (b) Which **one** of the following diagrams correctly shows how a ray of light travels through an optical fibre?

[1 mark]

Tick (✓) **one** box.

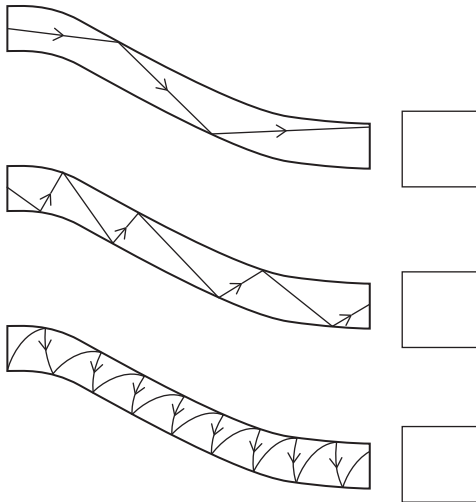

7 (c) Figure 10 shows a ray of light entering an optical fibre.

Figure 10

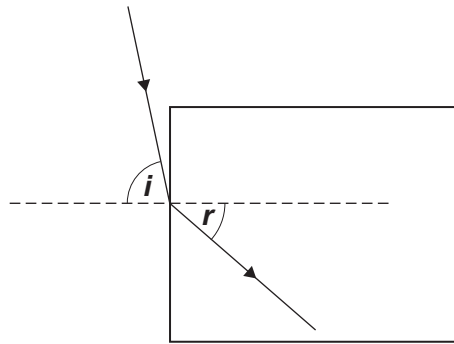

The angle of incidence i is 78°

The angle of refraction r is 40°

Calculate the refractive index of the optical fibre.

Use the correct equation from the Physics Equations Sheet.

[3 marks]

Refractive index = _____

5

Turn over for the next question

Turn over ►



- 8 (a)** Electromagnets are often used at recycling centres to separate some types of metals from other materials.

Give **one** reason why an electromagnet would be used rather than a permanent magnet.

[1 mark]

- 8 (b)** In this question you will gain marks for using good English, organising information clearly and using scientific words correctly.

Some students want to build an electromagnet.

The students have the equipment shown in **Figure 11**.

Figure 11

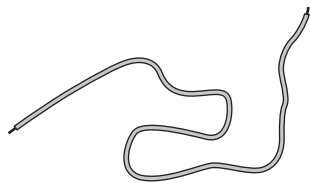

Insulated wire



Iron nail

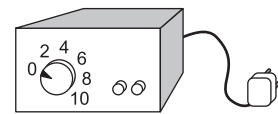

Power supply

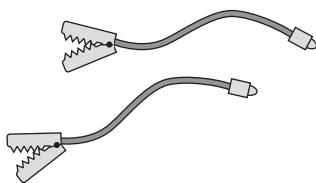

Connecting leads

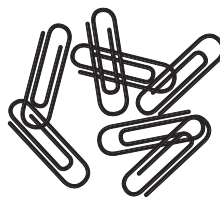

Steel paperclips

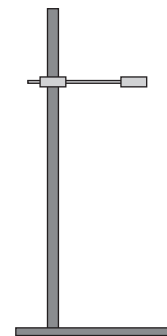

Wooden clamp
and stand



Describe how the students could build an electromagnet. Include in your answer how the students should vary and test the strength of their electromagnet.

[6 marks]

Extra space _____

7

Turn over for the next question

Turn over ►



There are no questions printed on this page

**DO NOT WRITE ON THIS PAGE
ANSWER IN THE SPACES PROVIDED**



- 9 **Figure 12** shows the structure of a traditional transformer.

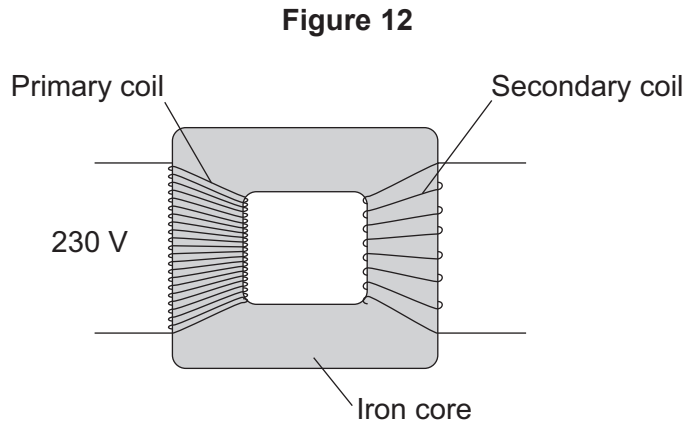

- 9 (a) There is an alternating current in the primary coil of the transformer.

State what is produced in the iron core.

[2 marks]

- 9 (b) A transformer has only **one** turn of wire on the secondary coil.
The potential difference across the secondary coil is 11.5 V
The potential difference across the primary coil is 230 V

Calculate the number of turns on the primary coil.

Use the correct equation from the Physics Equations Sheet.

[2 marks]

Number of turns on the primary coil = _____

Question 9 continues on the next page

Turn over ►



9 (c) In most transformers, the power output is less than the power input.

State why.

[1 mark]

9 (d) Two students investigated how magnets can be used to produce a potential difference. The students held a coil of wire above a magnet. The students quickly lowered the coil so that the magnet was inside the coil, as shown in **Figure 13**.

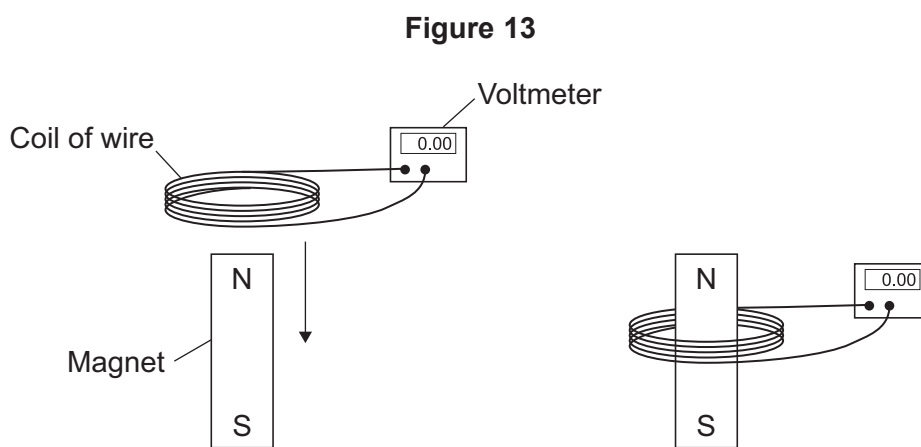

The students recorded the maximum potential difference for coils with different numbers of turns of wire. The results are shown in **Table 2**.

Table 2

Number of turns of wire in the coil	Maximum potential difference in volts	
	Results from student 1	Results from student 2
5	0.09	0.08
10	0.20	0.15
15	0.31	0.25
20	0.39	0.33
25	0.51	0.39



9 (d) (i) State the resolution of the voltmeter.

Give **one** reason why the resolution of the voltmeter is suitable for this investigation.

[2 marks]

Resolution _____

Reason _____

9 (d) (ii) The two students used exactly the same equipment to carry out their investigations. Both students recorded their results correctly.

Give the reason why student 2 got different results from student 1.

[1 mark]

9 (d) (iii) The students decided that even though the results were different, there was no need to repeat the investigation.

How do the results show that the investigation is reproducible?

[1 mark]

9 (d) (iv) State the name of the process which causes the potential difference to be produced in this investigation.

[1 mark]

9 (e) A transformer has been developed that can be used with many different devices.

Suggest **one** advantage of having a transformer that can be used with many different devices.

[1 mark]

END OF QUESTIONS



There are no questions printed on this page

**DO NOT WRITE ON THIS PAGE
ANSWER IN THE SPACES PROVIDED**

Copyright information

For confidentiality purposes, from the November 2015 examination series, acknowledgements of third party copyright material will be published in a separate booklet rather than including them on the examination paper or support materials. This booklet is published after each examination series and is available for free download from www.aqa.org.uk after the live examination series.

Permission to reproduce all copyright material has been applied for. In some cases, efforts to contact copyright-holders may have been unsuccessful and AQA will be happy to rectify any omissions of acknowledgements. If you have any queries please contact the Copyright Team, AQA, Stag Hill House, Guildford, GU2 7XJ.

Copyright © 2016 AQA and its licensors. All rights reserved.

