



Centre Number

71	
----	--

Candidate Number

--

General Certificate of Secondary Education
2013

Motor Vehicle and Road User Studies

Unit 1: Motor Vehicle and Road User Theory

Foundation Tier

[GMV11]

THURSDAY 16 MAY, MORNING

ML

For Examiner's use only	
Question Number	Marks
1-3	
4-9	
10-14	
15-20	
21	
22	
23	
24	
25	
26	
27	
28	
29	
30	
31	
32	
33	
34	
35	
36	
37	
38	
39	
40	
41	
42	
43	
44	

Total Marks	
--------------------	--

TIME

1 hour 30 minutes, plus your additional time allowance.

INSTRUCTIONS TO CANDIDATES

Write your Centre Number and Candidate Number in the spaces provided at the top of this page.
Answer **all** questions.

INFORMATION FOR CANDIDATES

The total mark for this paper is 120.
Figures in brackets printed down the right-hand side of pages indicate the marks awarded to each question or part question.
Quality of written communication will be assessed in question **44**.

Section A

Answer **all** questions.

- 1 Which warning sign, (a), (b) or (c) below, would be used to show the hazard on the road ahead?

Answer _____ [1]



© John McMorrow / CCEA

Fig. 1.1



(a)



(b)



(c)

© Crown Copyright – Department for Transport

- 2 _____ crossings allow cyclists and pedestrians to share crossing space and cross at the same time. [1]

- 3 _____ is a word used to describe travelling in a neutral gear or with the clutch pressed down. [1]

Examiner Only	
Marks	Remark

- 4 Advice given in the Highway Code to help all road users crossing a road
is called the _____
_____ . [1]
- 5 _____ is another word used to describe tiredness. [1]
- 6 A broken down vehicle which is parked along the side of a road should
have its _____ lights on. [1]
- 7 Engineering, _____ and Education are all methods used to
help reduce road accidents. [1]
- 8 An endorsable ticket issued by the police imposes a fine and
_____ . [1]
- 9 The arm signals below mean: Stop, traffic is approaching from both front
and _____ . [1]



Fig. 9.1

© Crown copyright – *The Official Highway Code for Northern Ireland, 2008.*

Examiner Only	
Marks	Remark

10 What is the name given to the road markings below? _____ [1]

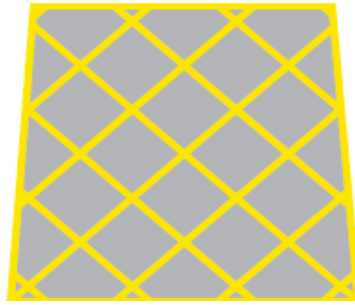

Fig. 10.1

© Crown Copyright – Department for Transport

11 A document which provides details about legal proof of insurance is known as the Insurance _____ . [1]

12 Which **one** of the following is the odd one out? Answer _____ [1]

- | | | | | |
|-----------------|----------|----------------|-----------------|---------|
| Driving Licence | Tax Disc | Petrol Receipt | MOT Certificate | V5 Form |
|-----------------|----------|----------------|-----------------|---------|

13 Hydrocarbons and carbon monoxide are two examples of _____ . [1]

14 _____ is the term used to describe a vehicle which is bought without trading another in. [1]

- 15 A Honda jeep costs £9,000. I can either pay £255 a month for three years or pay cash. If I pay cash, I would save £ _____ . [1]
- 16 A casualty who looks pale, feels faint or dizzy and is very thirsty is likely to be suffering from _____ . [1]
- 17 A _____ controls the temperature of water in a vehicle's cooling system. [1]
- 18 The cylinder below is on the _____ stroke. [1]



Fig. 18.1

© Motor Vehicle and Road Users Studies by Eamonn McPolin,
published by Colourpoint Books, 2009. ISBN 9781906578312

- 19 The _____ allows one rear wheel to turn faster than the other when going round corners. [1]
- 20 The component fitted to a vehicle's exhaust pipe to reduce noise is known as a _____ box. [1]

Section B

Answer **all** questions.

Examiner Only	
Marks	Remark

21 Why do tyres have a tread pattern?

_____ [1]

22 Name **one** item which, by law, must be kept clean on a motor vehicle.

_____ [1]

23 (a) Write down the legal limit for alcohol in:

1. breath _____ micrograms per 100 ml. [1]

2. blood _____ milligrams per 100 ml. [1]

(b) Write down **two** ways alcohol/drugs can affect a driver.

1. _____ [1]

2. _____ [1]

24 Primary road signs have _____ lettering on

a _____ background. [2]

25 Apart from a helmet, name **two** articles of clothing which each of the following should wear.

Cyclist 1. _____ [1]

2. _____ [1]

Motorcyclist 1. _____ [1]

2. _____ [1]

Examiner Only	
Marks	Remark

26 (a) Apart from the legal requirement, explain briefly why a motorist needs insurance.

_____ [1]

(b) List **three** reasons why young, newly qualified, male drivers are a high insurance risk.

1. _____ [1]

2. _____ [1]

3. _____ [1]

27 Write down the meanings of the following initials:

ABS _____ [1]

SORN _____ [1]

PCV _____ [1]

28 (a) At night, when should a driver use his/her main beam?

_____ [1]

(b) When should a driver adjust the vehicle's headlights?

 _____ [2]

32 (a) A car costs £15,300. Calculate the monthly repayments over 36 months.

Answer £ _____ [1]

(b) The buyer decides to make a 20% deposit to buy the car, with repayments over 36 months. Calculate the monthly repayments.

Answer £ _____ [2]

(c) Calculate the distance a vehicle would travel with a 15 gallon tank and a fuel consumption of 55 mpg.

Answer _____ miles [1]

Examiner Only	
Marks	Remark

Examiner Only	
Marks	Remark

33 (a) Name the **three** actions you should complete on arrival at an accident scene, in order of priority.

1. _____ [1]

2. _____ [1]

3. _____ [1]

(b) At the scene of an accident, list **two** ways in which you could make a vehicle safe.

1. _____ [1]

2. _____ [1]

34 (a) Apart from the engine, suggest a source of the power for power steering.

_____ [1]

(b) Explain briefly a compression ratio of 12:1, in relation to combustion.

_____ [1]

(c) List **two** reasons why regular maintenance checks are necessary on a motor vehicle.

1. _____ [1]

2. _____ [1]

(d) List **two** items which you should check weekly on your vehicle.

1. _____ [1]

2. _____ [1]

35 Give the meaning of each of the road signs shown in Fig. 35.1–35.6 below, as stated in the Highway Code.



Fig. 35.1



Fig. 35.2



Fig. 35.3



Fig. 35.4



Fig. 35.5



Fig. 35.6

© Crown Copyright – Department for Transport

Fig. 35.1 _____ [1]

Fig. 35.2 _____ [1]

Fig. 35.3 _____ [1]

Fig. 35.4 _____ [1]

Fig. 35.5 _____ [1]

Fig. 35.6 _____ [1]

36 (a) Explain briefly why the two second rule is important to road safety.

 _____ [1]

(b) When should the two second rule be increased?

 _____ [1]

Examiner Only	
Marks	Remark

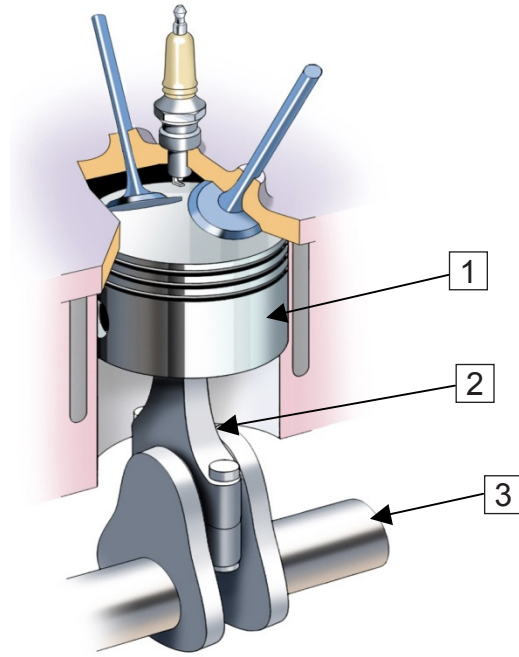

Fig. 39.1
 © *Motor Vehicle and Road Users Studies* by Eamonn McPolin,
 published by Colourpoint Books, 2009. ISBN 9781906578312

(a) Name the parts marked 1 to 3 in **Fig. 39.1** above.

- 1. _____ [1]
- 2. _____ [1]
- 3. _____ [1]

(b) Explain briefly how linear motion is changed into circular motion in a car engine.

 _____ [2]

Examiner Only	
Marks	Remark

(c)

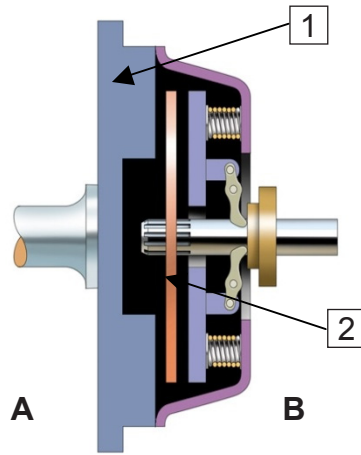

Fig. 39.2

© Motor Vehicle and Road Users Studies by Eamonn McPolin, published by Colourpoint Books, 2009. ISBN 9781906578312

Name the parts marked 1 and 2 in Fig. 39.2 above.

1. _____ [1]

2. _____ [1]

(d) Explain briefly the function of a clutch.

_____ [1]

(e) On which side of the clutch in Fig. 39.2 would you expect to find the engine? Answer A or B.

_____ [1]

Examiner Only	
Marks	Remark

40 (a) Apart from resting the night before, list **two** ways **you** could prepare for a long car journey.

1. _____ [1]

2. _____ [1]

(b) Apart from checking fuel, list **two** ways you could prepare **your vehicle** for a long journey.

1. _____ [1]

2. _____ [1]

(c) Write down **one** reason why speed limits are lower on single carriageway roads rather than on dual carriageways or motorways.

_____ [1]

41 (a) The maximum speed limit on a motorway is _____ mph. [1]

(b) Name the approach road used when joining a motorway.

_____ [1]

(c) What must you do if you have missed your exit on the motorway?

_____ [1]

(d) Name **two** vehicles restricted from using the third, outside lane of a motorway.

1. _____ [1]

2. _____ [1]

Examiner Only

Marks Remark

42 Apart from overtaking, name **two** occasions when a driver would use MSM on a motorway.

1. _____ [1]

2. _____ [1]

43 Describe briefly what you should do if your vehicle breaks down on a motorway.

_____ [6]

Examiner Only	
Marks	Remark

44 Safe driving involves observation, courtesy and anticipation. Explain briefly how you can do this, using the headings below.

Observation

Courtesy

Examiner Only	
Marks	Remark

Anticipation

[12]

Examiner Only	
Marks	Remark

Permission to reproduce all copyright material has been applied for.
In some cases, efforts to contact copyright holders may have been unsuccessful and CCEA
will be happy to rectify any omissions of acknowledgement in future if notified.