

Surname
Other Names

Centre Number

Candidate Number
0



## GCSE LINKED PAIR PILOT

4364/01

### METHODS IN MATHEMATICS UNIT 2: Methods (Calculator) FOUNDATION TIER

A.M. TUESDAY, 17 June 2014

1 hour 30 minutes

#### ADDITIONAL MATERIALS

A calculator will be required for this paper.

#### INSTRUCTIONS TO CANDIDATES

Use black ink or black ball-point pen.

Write your name, centre number and candidate number in the spaces at the top of this page.

Answer **all** the questions in the spaces provided.

Take  $\pi$  as 3.14 or use the  $\pi$  button on your calculator.

#### INFORMATION FOR CANDIDATES

You should give details of your method of solution when appropriate.

Unless stated, diagrams are not drawn to scale.

Scale drawing solutions will not be acceptable where you are asked to calculate.

The number of marks is given in brackets at the end of each question or part-question.

You are reminded that assessment will take into account the quality of written communication (including mathematical communication) used in your answer to question 5.

For Examiner's use only		
Question	Maximum Mark	Mark Awarded
1.	4	
2.	10	
3.	4	
4.	6	
5.	6	
6.	7	
7.	13	
8.	5	
9.	6	
10.	3	
11.	8	
12.	5	
13.	3	
<b>Total</b>	<b>80</b>	

**Formula List**

**Area of trapezium** =  $\frac{1}{2}(a + b)h$

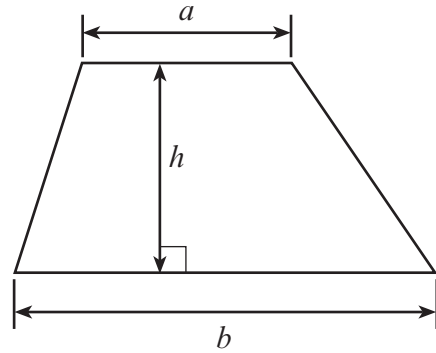

**Volume of prism** = area of cross-section  $\times$  length





2. (a) Write down the **largest** four digit number that can be made using all the digits 3, 2, 7 and 8. [1]

.....

- (b) Write down the **smallest odd** four digit number that can be made using all the digits 3, 2, 7 and 8. [1]

.....

- (c) Circle **three** of the following that have the same value as  $\frac{4}{10}$ . [3]

**40%**

**4%**

**0.04**

**$\frac{2}{4}$**

**0.4**

**0.25**

**$\frac{2}{5}$**

- (d) Ceri pays for 7 toys with a £10 note.  
Each toy costs the same amount.  
He is given £1.53 change.  
How much does each toy cost? [3]

.....

.....

.....

.....

- (e) Use either the symbol < or > in order to make each statement true. [2]

2 ..... 9

10 ..... -1

-5 ..... -7

**BLANK PAGE**

3. (a)

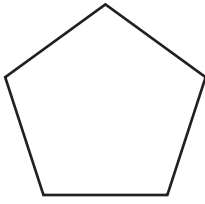
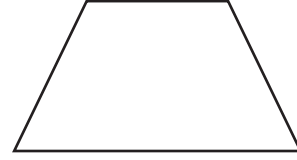
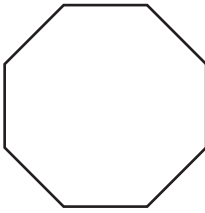
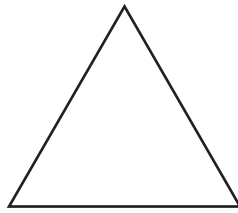
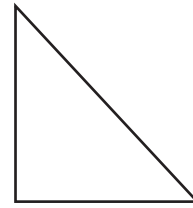
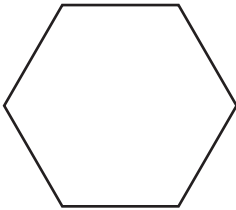
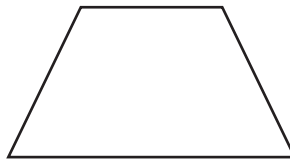
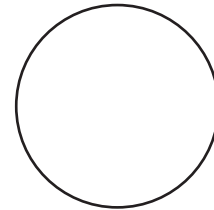
**A****B****C****D****E****F****G****H****I**

Use the diagrams above to identify and write down

[2]

- a pair of congruent shapes,

.....

- a pair of shapes that are similar but not congruent.

.....

- (b) Write down the special name of the straight line shown in each of the following diagrams.

[2]

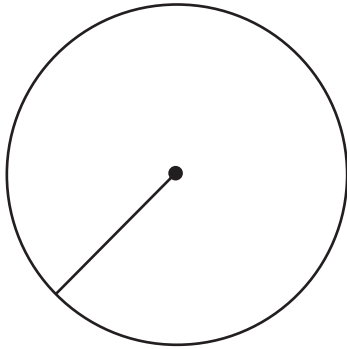

.....

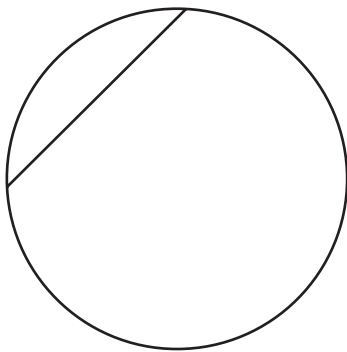

.....

Examiner  
only4364  
010007

4. (a) Fill in the smallest number of boxes to make the following diagram symmetrical about the line *AB*. [2]

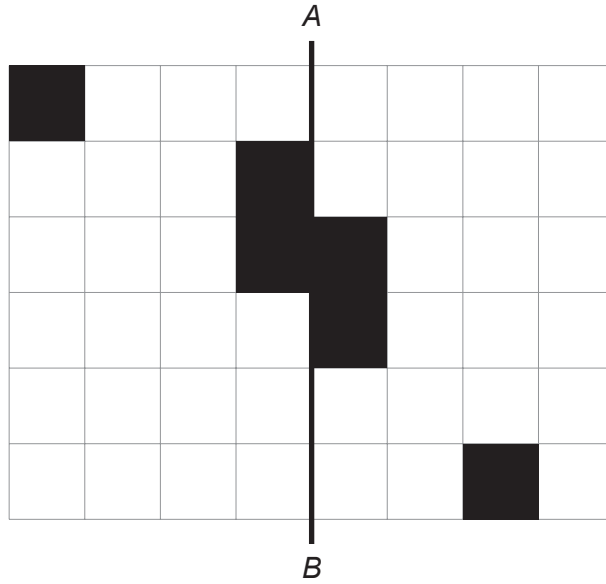

- (b) Write down the order of rotational symmetry of the shapes below. [2]



Order of rotational symmetry = .....

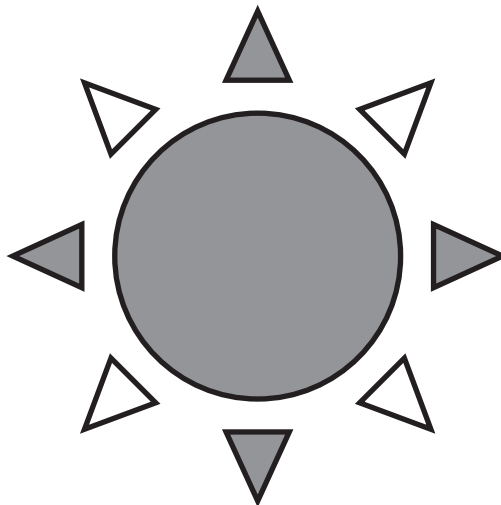

Order of rotational symmetry = .....



(c) Enlarge the following shape by a scale factor of 3.

[2]

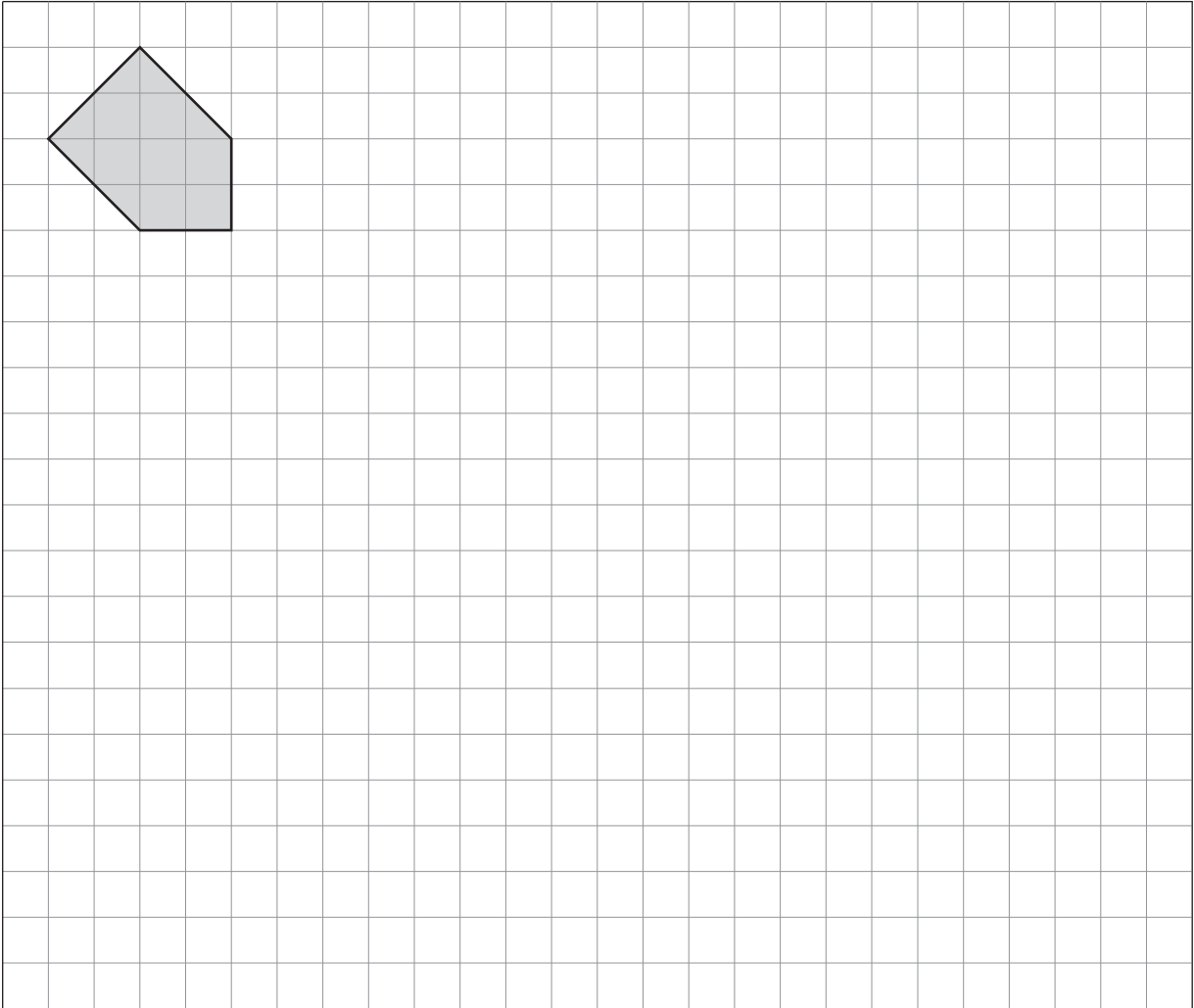

4364  
010009



6. (a) Find 67% of £234.

[2]

.....

.....

(b) Find  $\frac{2}{11}$  of 242 g.

[2]

.....

.....

(c) **Showing all your working**, write 24%, 0.3 and  $\frac{1}{4}$  in ascending order.

[3]

.....

.....

.....

.....

.....

.....

.....

.....

7. (a) The perimeter of a square is 20 cm.  
Calculate the area of this square.  
You must show the units of your answer.

[4]

.....

.....

.....

.....

.....

.....

.....

- (b) Calculate the area of the following triangle **giving your answer in m<sup>2</sup>**.

[3]

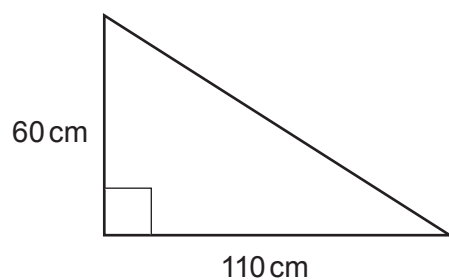

*Diagram not drawn to scale*

.....

.....

.....

.....

.....

.....

- (c) Shape A is a cube.  
Shape B is a cuboid.  
Both shape A and shape B have the same volume.  
What is the height of shape B?

[4]

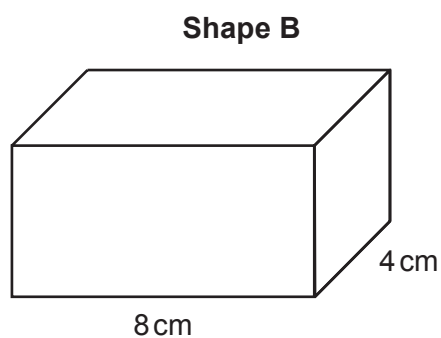
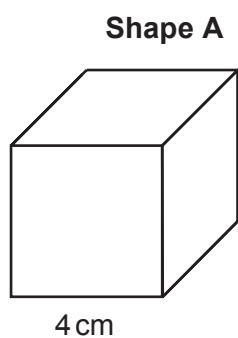

*Diagrams not drawn to scale*

.....

.....

.....

.....

.....

.....

- (d) Calculate the circumference of a circle with radius 20 cm.

[2]

.....

.....

.....

.....

8. (a) Solve  $x - 7 = 16$ .

[1]

.....

.....

(b) Solve  $5x = 20$ .

[1]

.....

.....

(c) Solve  $\frac{y}{8} = 9$ .

[1]

.....

.....

(d) Solve  $4a + 3 = 39$ .

[2]

.....

.....

9. (a) Use the following clues to find the missing number. [2]

- The number is between 8 and 9
- It is given correct to one decimal place
- It is exactly divisible by 0.3
- It is exactly divisible by 0.4

.....

.....

.....

.....

The missing number is: .....

(b) Find the value of  $\sqrt{634.1} - 2.42^3$ . Write down your answer correct to 2 decimal places. [2]

.....

.....

(c) Write down 2912 correct to 1 significant figure. [1]

.....

(d) Write down 0.0631 correct to 2 significant figures. [1]

.....

10. Part of a shape is shown on the grid. The dotted line is the line of symmetry of the shape. Complete the drawing of the shape and then rotate your complete shape through  $180^\circ$  about the origin. [3]

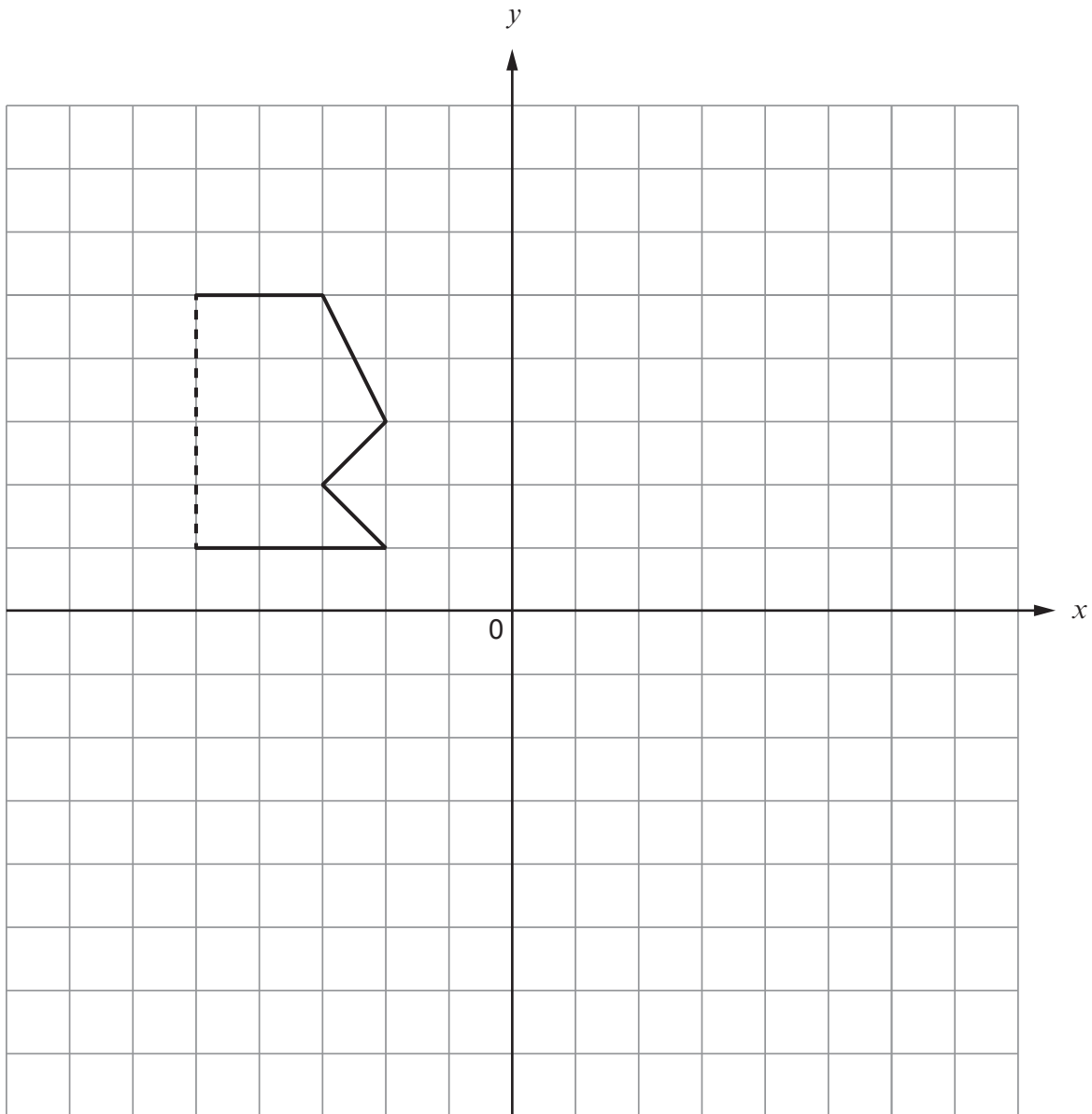



11. (a) Solve  $6(3x - 17) = 42$ .

[3]

.....

.....

.....

.....

(b) Solve the inequality  $9x + 5 < 77$ .

[2]

.....

.....

.....

(c) The angles of a triangle are  $x^\circ$ ,  $2x^\circ$  and  $3x^\circ$ .  
Form an equation in  $x$ , and use your equation to find the sizes of the three angles.

[3]

.....

.....

.....

.....

.....

.....

12. (a) Translate the triangle shown below by  $\begin{pmatrix} 8 \\ -2 \end{pmatrix}$ .

[1] Examiners only

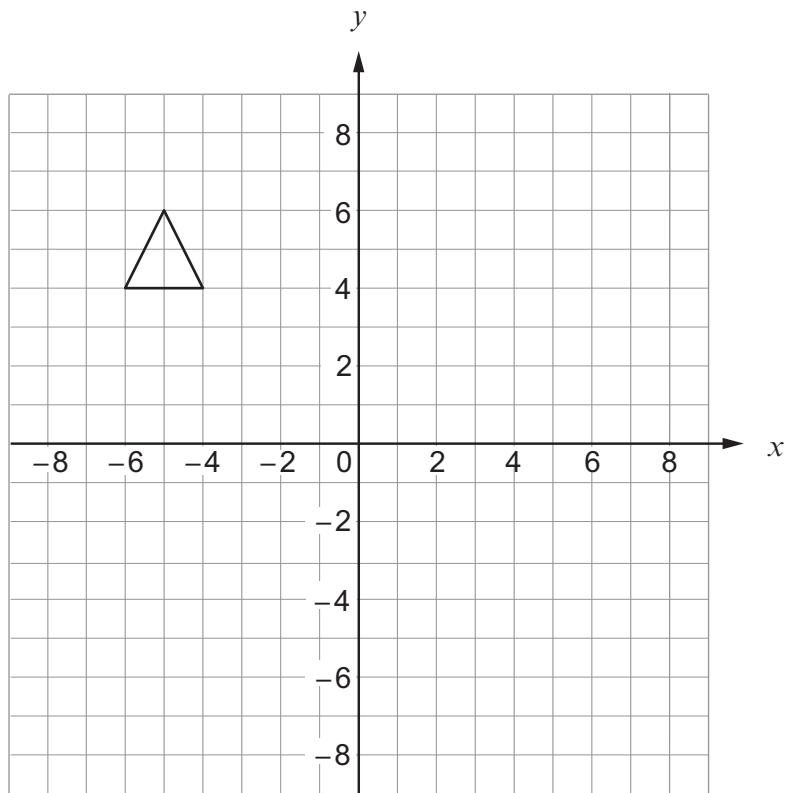

- (b) Rotate the triangle through  $90^\circ$  anticlockwise using the point  $(-2, -1)$  as the centre of the rotation.

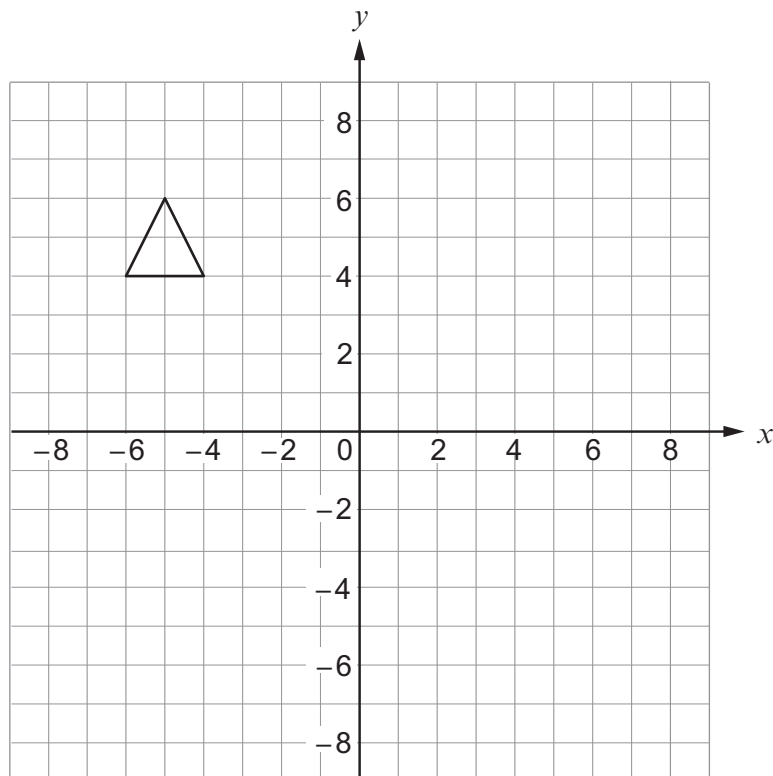

- (c) Reflect the triangle shown in the line  $y = x$ .

[2]

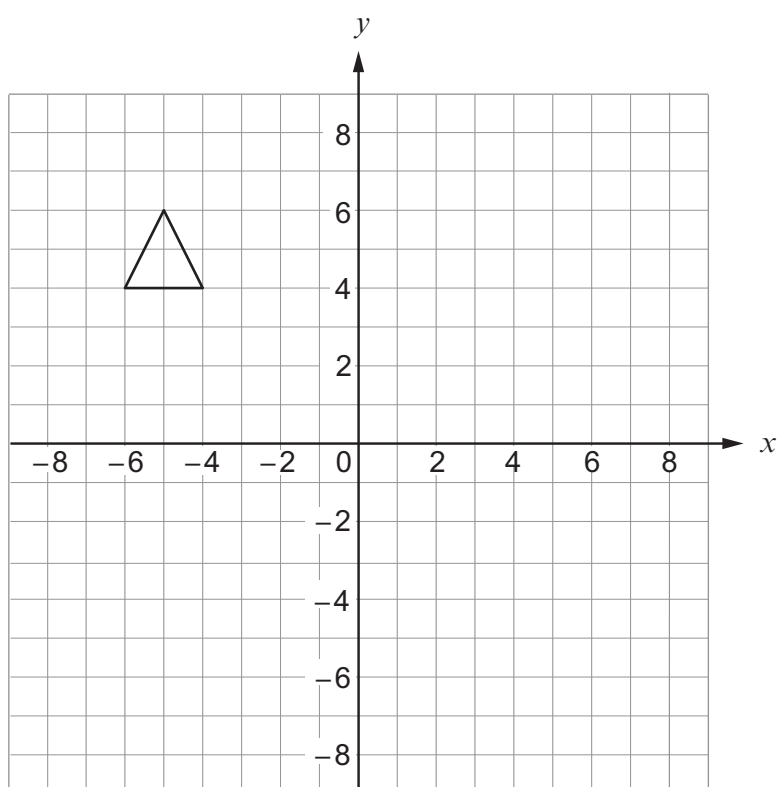
Examiner  
only

13.

[3]

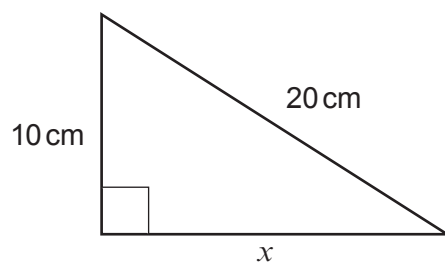

*Diagram not drawn to scale*

Calculate the length of the side marked  $x$ .

.....

.....

.....

.....

.....

**END OF PAPER**