

Surname	Centre Number	Candidate Number
Other Names		0



GCSE

4370/04

**MATHEMATICS – LINEAR
PAPER 2
FOUNDATION TIER**

A.M. MONDAY, 12 November 2012

1 $\frac{3}{4}$ hours

ADDITIONAL MATERIALS

A calculator will be required for this paper.

INSTRUCTIONS TO CANDIDATES

Use black ink or black ball-point pen.

Write your name, centre number and candidate number in the spaces at the top of this page.

Answer **all** the questions in the spaces provided.

Take π as 3.14 or use the π button on your calculator.

INFORMATION FOR CANDIDATES

You should give details of your method of solution when appropriate.

Unless stated, diagrams are not drawn to scale.

Scale drawing solutions will not be acceptable where you are asked to calculate.

The number of marks is given in brackets at the end of each question or part-question.

You are reminded that assessment will take into account the quality of written communication (including mathematical communication) used in your answer to question 11(a).

For Examiner's use only		
Question	Maximum Mark	Mark Awarded
1	6	
2	4	
3	7	
4	9	
5	4	
6	4	
7	4	
8	11	
9	4	
10	8	
11	9	
12	3	
13	4	
14	10	
15	6	
16	7	
TOTAL MARK		

4370
040001

Formula List

Area of trapezium = $\frac{1}{2}(a + b)h$

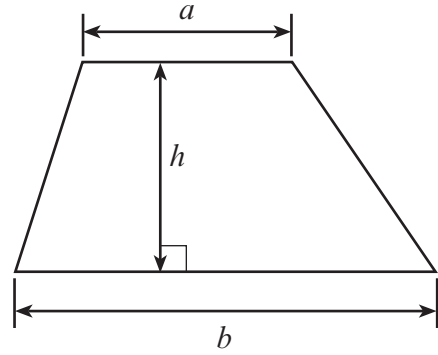

Volume of prism = area of cross-section \times length

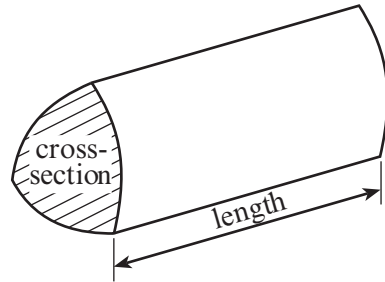

1. (a) A builder is renovating some flats.
He buys a washing machine, 6 tables, 2 sets of chairs and 3 cabinets.
Complete the following table to show his bill for these items.

Item	Cost (£)
1 washing machine @ £242.68	242.68
6 tables @ £24.36 each	
2 sets of chairs @ £43.75 per set	
3 cabinets @ £53.52 each	
Total	

[4]

- (b) The builder gets a 10% discount.
How much does the builder have to pay?

.....

.....

.....

[2]

2. **Circle** the quantity that is the appropriate estimate for each of the following.

Weight of a woman	50 g	500 kg	50 mg	50 kg
Volume of a glass of water	27 litres	270 ml	2.7 cm ³	270 litres
Height of a man	180 cm	18 m	180 mm	1800 cm
Distance from Calais to Paris	266 mm	266 cm	266 m	266 km

[4]

3. (a)

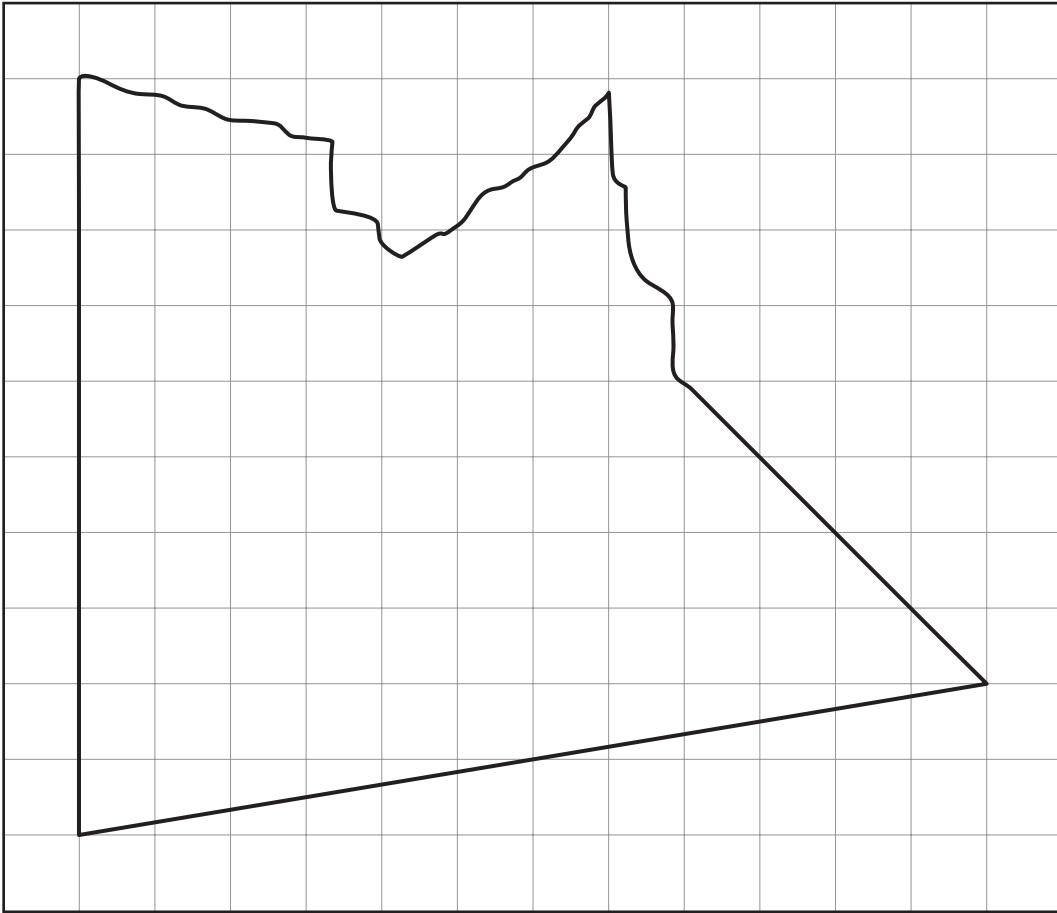

The above shape has been drawn on a centimetre squared grid.
Estimate the area of the above shape.

.....

.....

.....

.....

Area of the shape = cm²

[2]

(b) Complete the following figure so that it is symmetrical about the line AB .

[2]

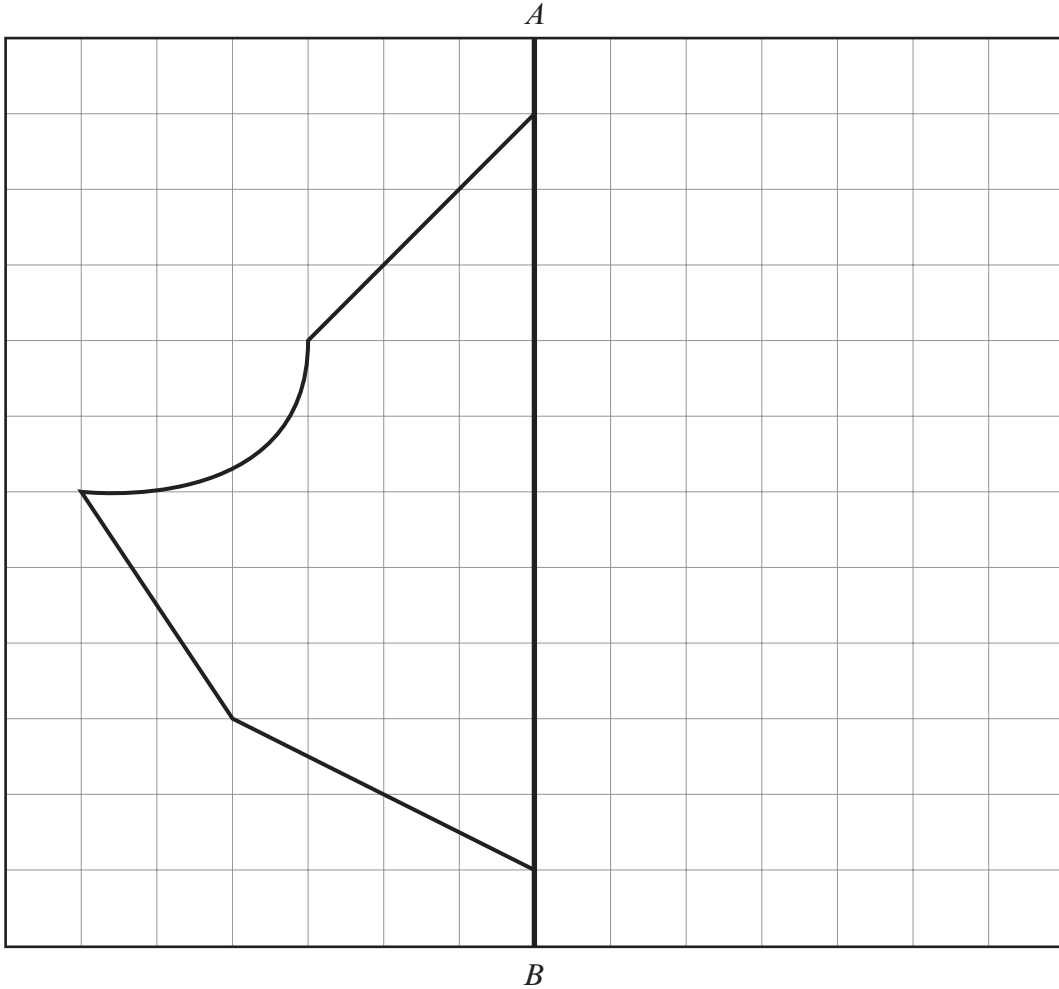

(c) Look at the angles a , b and c .
Write the letter of the angle alongside its special name.

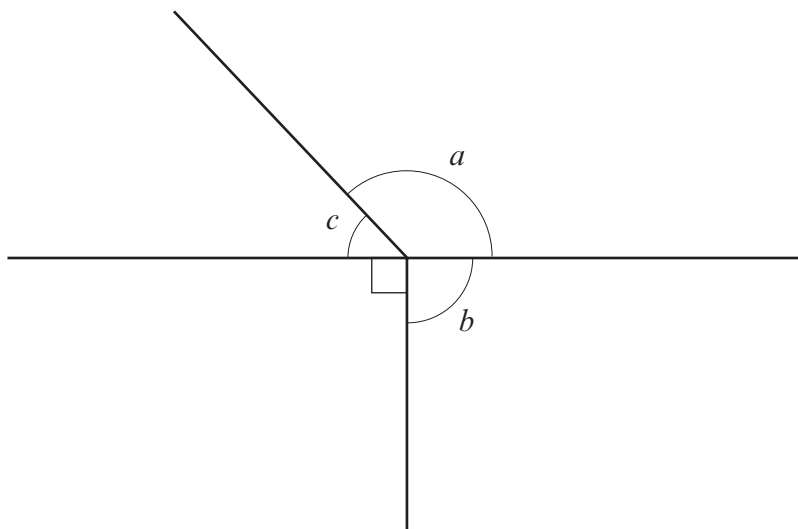

acute angle obtuse angle right angle

[3]

4. Forty pupils were asked to choose which of the seasons they preferred.
The results are shown below, using the codes:

	Spring (S)	Summer (U)	Autumn (A)	Winter (W)						
S	W	U	U	S	A	U	W	U	S	
A	U	W	S	U	A	S	A	U	U	
U	S	A	U	A	S	W	U	A	W	
W	U	S	W	U	U	S	A	S	U	

- (a) Using the centimetre squared grid on the opposite page, draw a bar chart for the data given.

.....

.....

.....

.....

.....

.....

.....

.....

.....

.....

[6]

(b) Write down the mode.

..... [1]

(c) Using these results, write down an estimate for the probability that a randomly chosen child prefers winter.

.....
.....
..... [2]

4370
040007

5. (a) Kevin has 10 coloured balls.
Some are yellow (Y), some are green (G) and some are pink (P).



He puts the 10 balls, shown above, into a bag, and then picks one ball at random from the bag.

On the probability scale shown below, mark the points **A**, **B** and **C** where

A is the probability that Kevin picks a pink ball.

B is the probability that Kevin does NOT pick a black ball.

C is the probability that Kevin picks a green ball.

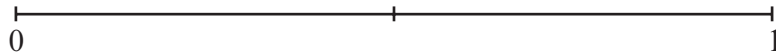

[3]

- (b) **Circle** the best expression from those given below to describe the chance of the event **A** occurring.

impossible **unlikely** **an even chance** **likely** **certain**

[1]

6. Each row of the following table needs to show equivalent fractions, decimals and percentages. The first row has been done for you. Complete the rest of the table.

Fraction	Decimal	Percentage
$\frac{1}{2}$	0.5	50%
$\frac{1}{4}$		25%
	0.6	
	0.75	75%

[4]

7. Gareth has tiles which are shaped like isosceles triangles.
For each tile, the side of the tile that is not equal to either of the other 2 sides has glue on it.
The glued side of each tile is the same length.

- (a) Gareth takes two **identical** isosceles triangular shaped tiles.
Gareth sticks the two glued sides together so that the two tiles make a quadrilateral shape.

What is the special name of the quadrilateral that Gareth has made?
Draw a sketch to show this.

Name of quadrilateral [2]

- (b) Gareth now takes two **different** isosceles triangular shaped tiles.
These tiles are **not** identical but their glued sides are of the same length.
Gareth sticks the two glued sides together so that the two tiles make a quadrilateral shape.

What is the special name of the quadrilateral that Gareth has made?
Draw a sketch to show this.

Name of quadrilateral [2]

8. (a) Describe **in words** a rule for continuing each of the following sequences.

(i) 82, 75, 68, 61, 54,

Rule:
..... [1]

(ii) 2, -4, 8, -16, 32,

Rule:
..... [1]

(b) (i) A sweet weighs w grams. Write down, in terms of w , the weight of 10 sweets.

..... [1]

(ii) A boy is 6 years older than his brother. One of the boys is x years old. Write down, in terms of x , the 2 possible ages of his brother.

.....
..... [1]

(c) Calculate $\frac{4}{9}$ of 45.

.....
..... [2]

(d) Given that $5W = 2P + 3R$, find the value of P when $W = 4$ and $R = -4$.

.....
.....
.....
..... [3]

(e) Solve $4x + 3 = 21$.

.....
.....
.....

[2]

9. Toby went on holiday to China.

(a) He changed £700 into Chinese yuan (CNY) when the exchange rate was $\text{£}1 = 9.79 \text{ CNY}$.
How many Chinese yuan (CNY) did he receive?

.....
.....
.....

[2]

(b) Whilst on holiday, he went on a tour which cost 2447.50 yuan.
What was the cost of the tour in pounds?

.....
.....
.....

[2]

10. Number sequences can be created by choosing a starting number and a step number. For example, if the starting number is 20 and the step number is 5, then the sequence would be

20	25	30	35	40
----	----	----	----	----

- (a) Write down the next 3 numbers of a sequence when the starting number is 10 and the step number is 7.

10			
----	--	--	--

[1]

A sequence can have negative steps.

- (b) Write down the next 3 numbers of a sequence when the starting number is 35 and the step number is -4 .

35	31			
----	----	--	--	--

[1]

- (c) A sequence has a starting number of 40 and a step number of 6. By considering the difference between 100 and 40, explain how you can decide whether or not the sequence will show the number 100 at some stage.

.....

.....

.....

[2]

- (d) Two pupils, John and Megan, play a game together. They each make up a sequence by independently choosing a starting number and a step number. Their choices are in the following table.

Pupil	Starting number	Step number
John	30	9
Megan	40	7

After how many steps will they show the same number at the same time and what is that number?

.....

.....

.....

[2]

- (e) They decide to find out, without writing down the sequences, if they can predict whether or not their sequences will show the same number at the same time, as they did in part (d).
They choose the following starting numbers and step numbers.

Pupil	Starting number	Step number
John	9	12
Megan	53	8

Explain how they can predict whether or not their sequences will show the same number at the same time.

.....

.....

.....

.....

.....

.....

[2]

11. (a) You will be assessed on the quality of your written communication in this question.

ABC is an equilateral triangle and $BCDE$ is a square.

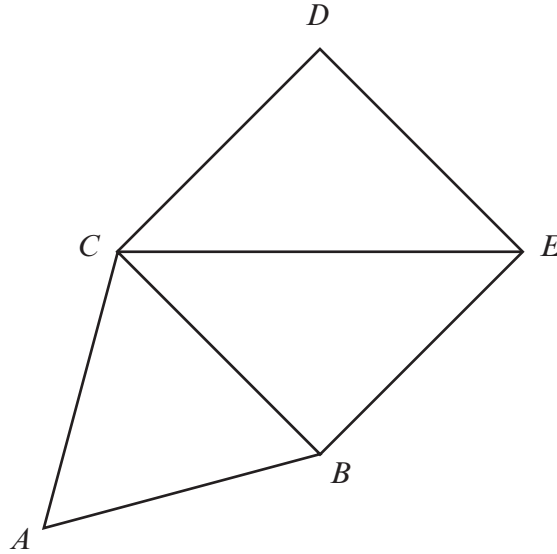

Diagram not drawn to scale

Find the size of \widehat{ACE} .

You must explain each step of your calculation and show all your working.

.....

.....

.....

.....

.....

.....

.....

.....

$$\widehat{ACE} = \dots\dots\dots^\circ$$

[5]

- (b) Using a ruler and a pair of compasses, bisect the angle given below.

[2]

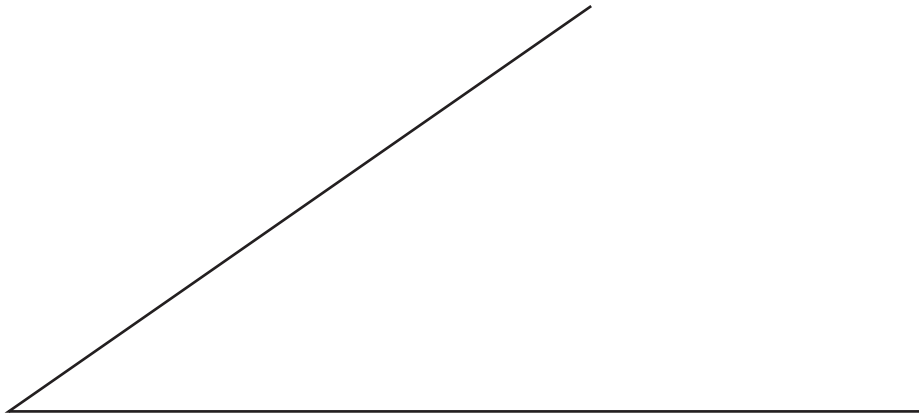

- (c) Using a ruler and a pair of compasses, construct a perpendicular to the line AB at X .

[2]

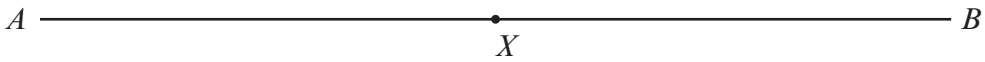

12. A ship is on a bearing of 215° from Holyhead and on a bearing of 324° from Cardigan. By drawing suitable lines, mark the position of the ship as C.

[3]



13. A solution to the equation

$$x^3 - 7x - 2 = 0$$

lies between 2 and 3.

Find this solution correct to 1 decimal place.

.....

.....

.....

.....

.....

.....

.....

.....

.....

.....

.....

.....

.....

.....

.....

.....

.....

.....

.....

[4]

14. The table below gives information from the Highway Code on stopping distances for cars.





Speed in mph	Stopping distance in metres = Thinking distance + Braking distance (Thinking distance is given first, followed by Braking distance)
20 mph	
30 mph	
40 mph	
50 mph	

Diagram not drawn to scale

- (a) A warning sign for a crossroads is to be placed on a road, which has a speed limit of 30 mph.
Use the data given above to find the minimum distance that the warning sign should be placed from the crossroads.

[1]

- (b) An average car is approximately 4 metres in length. How many car lengths is the stopping distance for a car travelling at 40 mph?

[2]

(c) Complete the table below.

Speed	
mph	km/h
30
50	80
.....	112

.....

.....

.....

.....

.....

.....

[3]

(d) The stopping distances given in the Highway Code are given assuming good driving conditions and alert drivers.
 When a driver is tired, the thinking distance increases by 30% and the braking distance increases by 20%.
 Calculate the stopping distance, in metres, for a tired driver travelling at 50 mph in good driving conditions.

.....

.....

.....

.....

.....

.....

[4]

15. Mr Jones' electricity quarterly statement from Welsh Energy is shown below.
 Some of the entries have been removed.
 He pays for his electricity by monthly direct debit payments.
 He gets a discount of £27.50 for paying by direct debit.
 Use the information given on the statement to complete all of the missing entries and to calculate the balance of Mr Jones' account.

<i>Welsh Energy</i>		Electricity Statement		
		<i>Period: 1st July 2012 to 30th September 2012</i>		
A Jones 54 Forest View Swansea				
Meter reading last time	Meter reading this time	Units used	Price of each unit in pence	Amount £
4267	4921	Units used	26.5
		Quarterly charge		30.45
		Total charge	
		VAT at 5% of the total charge	
		Balance from previous quarter		42.36 CR
		Total to pay	
		Payments received		
		Direct Debit Discount		27.50 CR
		Payment received 18th July 2012		55.00 CR
		Payment received 18th August 2012		55.00 CR
		Payment received 18th September 2012		55.00 CR
		Balance to carry forward to next quarter	

Working

.....

.....

.....

.....

.....

.....

.....

.....

.....

.....

[6]

16. (a)

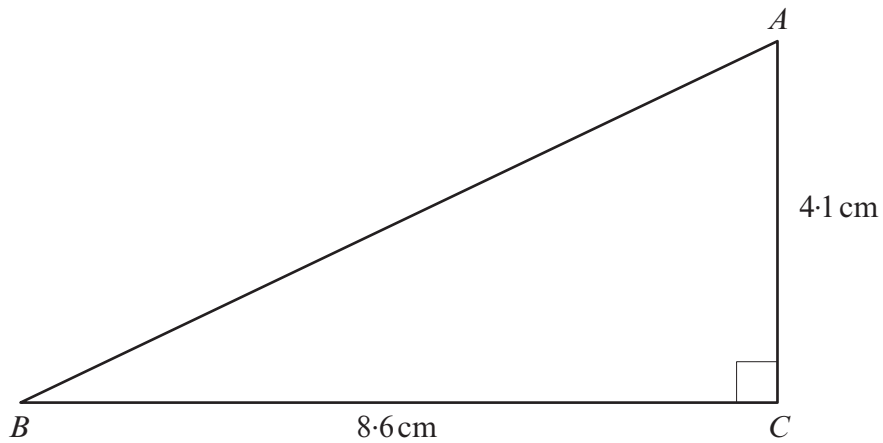

Diagram not drawn to scale

(a) Calculate the area of the triangle ABC .

.....

.....

.....

.....

[2]

(b) Calculate the perimeter of the triangle ABC , giving your answer correct to 2 significant figures.

.....

.....

.....

.....

.....

.....

.....

.....

[5]