

GENERAL CERTIFICATE OF SECONDARY EDUCATION
MATHEMATICS C (GRADUATED ASSESSMENT)
MODULE M1 – SECTION B

B271B

Candidates answer on the Question Paper

OCR Supplied Materials:
None

- Other Materials Required:**
- Geometrical instruments
 - Tracing paper (optional)
 - Electronic calculator

Thursday 21 January 2010
Afternoon

Duration: 30 minutes



Candidate Forename		Candidate Surname	
--------------------	--	-------------------	--

Centre Number						Candidate Number				
---------------	--	--	--	--	--	------------------	--	--	--	--

INSTRUCTIONS TO CANDIDATES

- Write your name clearly in capital letters, your Centre Number and Candidate Number in the boxes above.
- Use black ink. Pencil may be used for graphs and diagrams only.
- Read each question carefully and make sure that you know what you have to do before starting your answer.
- Show your working. Marks may be given for a correct method even if the answer is incorrect.
- Answer **all** the questions.
- Do **not** write in the bar codes.
- Write your answer to each question in the space provided, however additional paper may be used if necessary.

INFORMATION FOR CANDIDATES

- The number of marks is given in brackets [] at the end of each question or part question.
- Section B starts with question 6.
- You are expected to use a calculator in Section B of this paper.
- The total number of marks for this Section is **25**.
- This document consists of **12** pages. Any blank pages are indicated.

Formulae Sheet

Area of trapezium = $\frac{1}{2}(a + b)h$

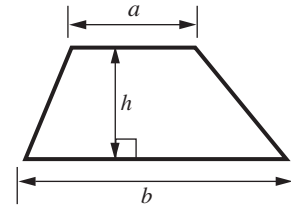

Volume of prism = (area of cross-section) \times length

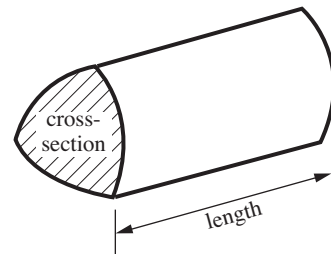

PLEASE DO NOT WRITE ON THIS PAGE



- (a) How much does each battery cost?
Give your answer in pence.

(a) p [2]

- (b) Write down **one** even number that is printed on the pack.

(b) [1]

- (c) Mrs Bentham needs 28 of these batteries for a class project.
How many of these packs does she need?

(c) [1]

7 100 g of cereal contains the following:

Protein	15g
Carbohydrate	75g
Fat	2g
Fibre	3g
Other	5g

(a) (i) Work out the total weight of Protein and Fibre in 100 g of this cereal.

(a)(i) g [1]

(ii) How much of the 100 g of cereal is **not** Carbohydrate?

(ii) g [2]

(b) The energy value of 100 g of cereal is 1586kJ.

Round 1586 to the nearest 100.

(b) [1]

(c) Brendan has a 500 g box of cereal.

He has eaten $\frac{1}{4}$ of the cereal.

Find $\frac{1}{4}$ of 500 g.

(c) g [1]

8 Here is some information about sea creatures.

Giant Squid		Minke whale		Walrus		Killer whale	
Weight	275 kg	Weight	9000 kg	Weight	1954 kg	Weight	7257 kg
Length	19 m	Length	9 m	Length	5 m	Length	18 m

(a) (i) Which of these weights is in the 10 times table?

(a)(i) [1]

(ii) Put these sea creatures in order of weight, heaviest first.

..... [2]
heaviest

(b) What is the difference in length between the longest of these sea creatures and the shortest?

(b) m [2]

- 9 Akil makes a spinner for a game.
He draws it on a grid and then decides that he needs a larger version.

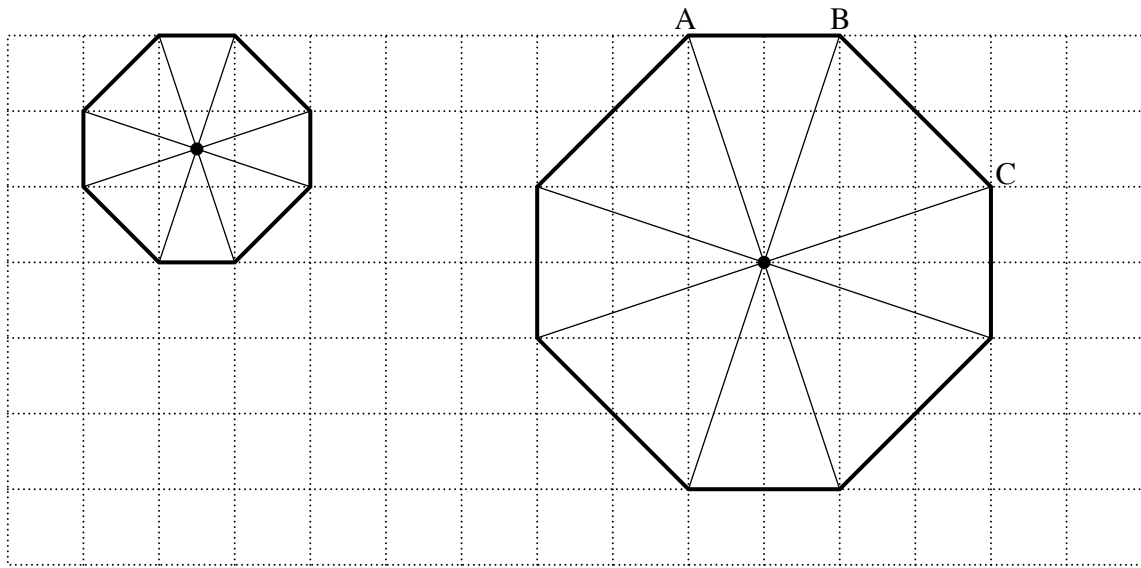

- (a) How many times bigger are the sides of Akil's large spinner than his small spinner?

(a) [1]

- (b) (i) Measure the length of line BC accurately.
Give the units of your answer.

(b)(i) BC = [2]

- (ii) Is the spinner fair?
Explain your answer.

*Write Yes
or No.*

..... because
..... [2]

10 (a)

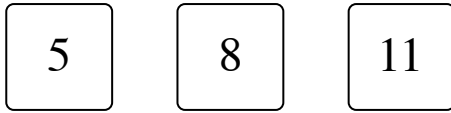

These numbers form the start of a pattern using the rule:

Add 3

Find the next three numbers in the pattern.

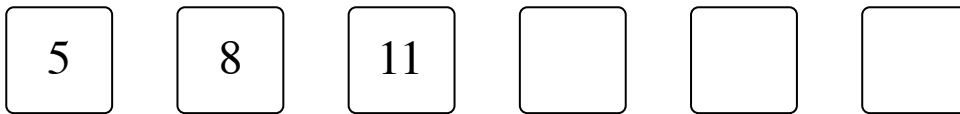

[1]

(b) This is part of another pattern.

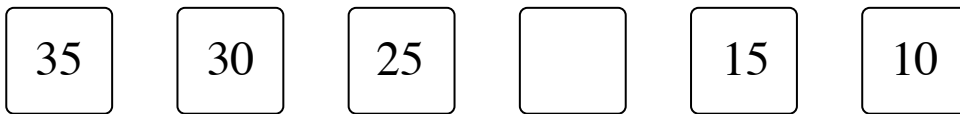

(i) What is the rule for this pattern?

(b)(i) [1]

(ii) What number has been missed out of the pattern?

(ii) [1]

- 11 Tony needs to know his height and his weight.

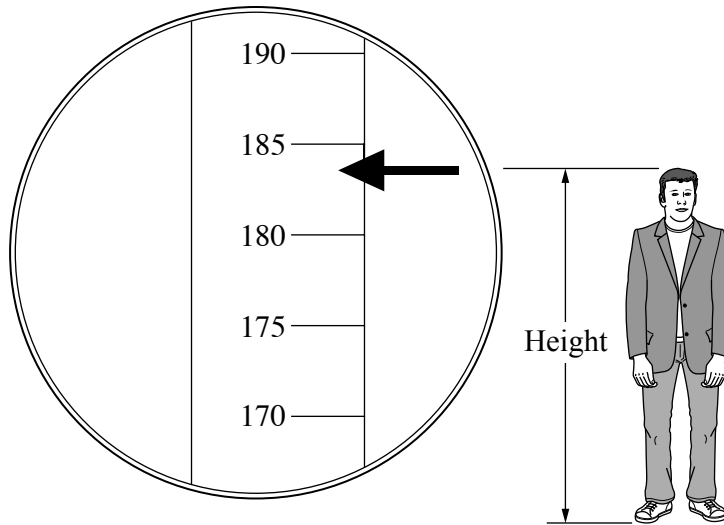

Tony has a tape that measures centimetres.
He marks the tape to show his height.

- (a) What is Tony's height in centimetres?

(a) cm [1]

- (b) Use this function machine to change Tony's height to metres.

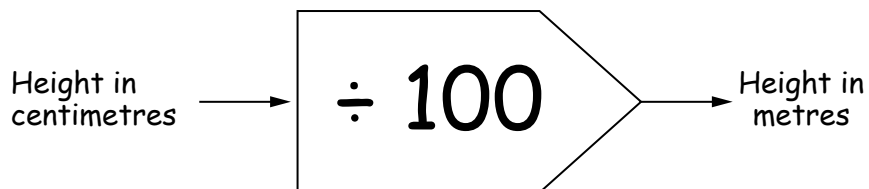

(b) m [1]

Tony weighed himself.

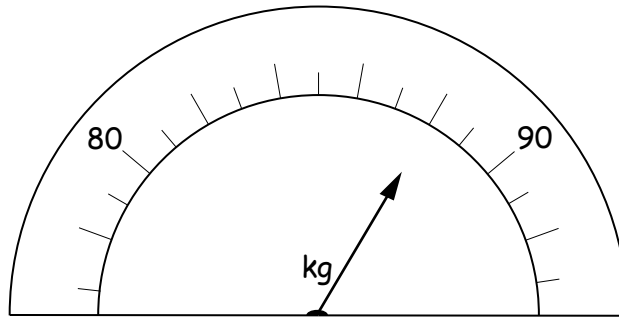

(c) What is Tony's weight in kilograms?

(c) kg [1]

PLEASE DO NOT WRITE ON THIS PAGE

PLEASE DO NOT WRITE ON THIS PAGE

PLEASE DO NOT WRITE ON THIS PAGE



Copyright Information

OCR is committed to seeking permission to reproduce all third-party content that it uses in its assessment materials. OCR has attempted to identify and contact all copyright holders whose work is used in this paper. To avoid the issue of disclosure of answer-related information to candidates, all copyright acknowledgements are reproduced in the OCR Copyright Acknowledgements Booklet. This is produced for each series of examinations, is given to all schools that receive assessment material and is freely available to download from our public website (www.ocr.org.uk) after the live examination series.

If OCR has unwittingly failed to correctly acknowledge or clear any third-party content in this assessment material, OCR will be happy to correct its mistake at the earliest possible opportunity.

For queries or further information please contact the Copyright Team, First Floor, 9 Hills Road, Cambridge CB2 1GE.

OCR is part of the Cambridge Assessment Group; Cambridge Assessment is the brand name of University of Cambridge Local Examinations Syndicate (UCLES), which is itself a department of the University of Cambridge.