

**GENERAL CERTIFICATE OF SECONDARY EDUCATION**  
**MATHEMATICS C (GRADUATED ASSESSMENT)**  
MODULE M2 – SECTION B

## B272B

Candidates answer on the question paper

**OCR Supplied Materials:**

None

**Other Materials Required:**

- Geometrical instruments
- Tracing paper (optional)
- Electronic calculator

**Monday 9 March 2009**  
**Morning**

**Duration: 30 minutes**



Candidate Forename		Candidate Surname	
--------------------	--	-------------------	--

Centre Number						Candidate Number				
---------------	--	--	--	--	--	------------------	--	--	--	--

**INSTRUCTIONS TO CANDIDATES**

- Write your name clearly in capital letters, your Centre Number and Candidate Number in the boxes above.
- Use black ink. Pencil may be used for graphs and diagrams only.
- Read each question carefully and make sure that you know what you have to do before starting your answer.
- Show your working. Marks may be given for a correct method even if the answer is incorrect.
- Answer **all** the questions.
- Do **not** write in the bar codes.
- Write your answer to each question in the space provided, however additional paper may be used if necessary.

**INFORMATION FOR CANDIDATES**

- The number of marks is given in brackets [ ] at the end of each question or part question.
- Section B starts with question 8.
- You are expected to use a calculator in Section B of this paper.
- The total number of marks for this Section is **25**.
- This document consists of **8** pages. Any blank pages are indicated.

<b>FOR EXAMINER'S USE</b>	
<b>SECTION B</b>	

## Formulae Sheet

$$\text{Area of trapezium} = \frac{1}{2}(a + b)h$$

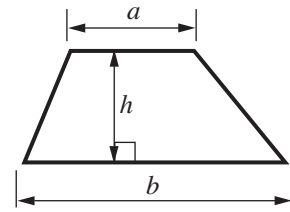

$$\text{Volume of prism} = (\text{area of cross-section}) \times \text{length}$$

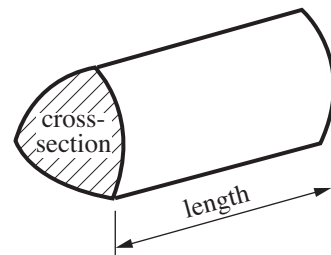

**PLEASE DO NOT WRITE ON THIS PAGE**

8 Here are the numbers of fish caught by some anglers.

2 0 9 2 1 5 1 0 1 2 9 6 1

(a) Find the mode.

(a) ..... [1]

(b) Find the median.

(b) ..... [2]

9 Here are the first four terms in a number pattern.

5 8 11 14

(a) Write down the next number in the pattern.

(a) ..... [1]

(b) Explain how you worked out your answer.

..... [1]

- 10 There are 32 students in Mr Brown's class.  
The students are asked:

How do you usually travel to school?

Here are the results.

Walk 9      Bus 16      Train 4      Car 3

Mr Brown chooses a student at random.

Use arrows to mark the following on the probability line below.

- (a) The probability that he chooses a student who travels by bus.  
Label this arrow **B**. [1]
- (b) The probability that he chooses a student who travels by train.  
Label this arrow **T**. [1]

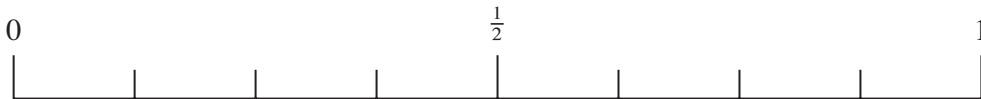

- 11 Here are some temperatures.

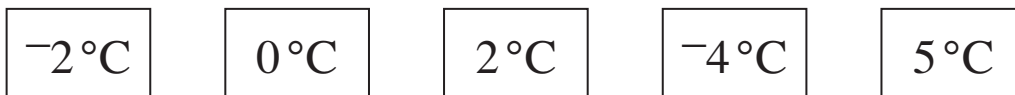

- (a) Write down the warmest of these temperatures.  
(a) .....  $^{\circ}\text{C}$  [1]
- (b) Write down the coldest of these temperatures.  
(b) .....  $^{\circ}\text{C}$  [1]

12 This car is 4.5 metres long and 2 metres high.

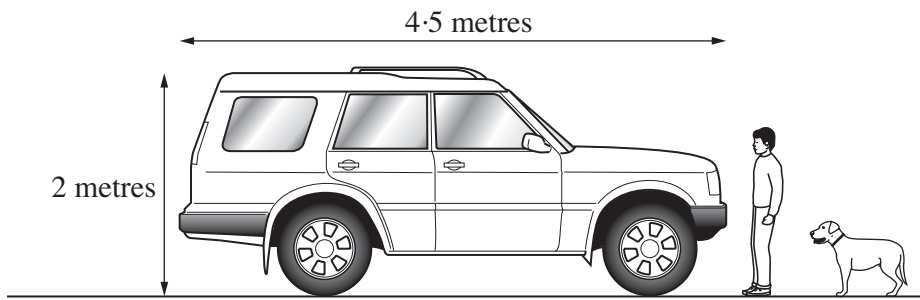

(a) Estimate the height of the boy.

(a) ..... m [1]

(b) Estimate the length of the dog.

(b) ..... m [1]

- 13 Henry asked 60 students to choose their favourite subject. This pie chart shows his results.

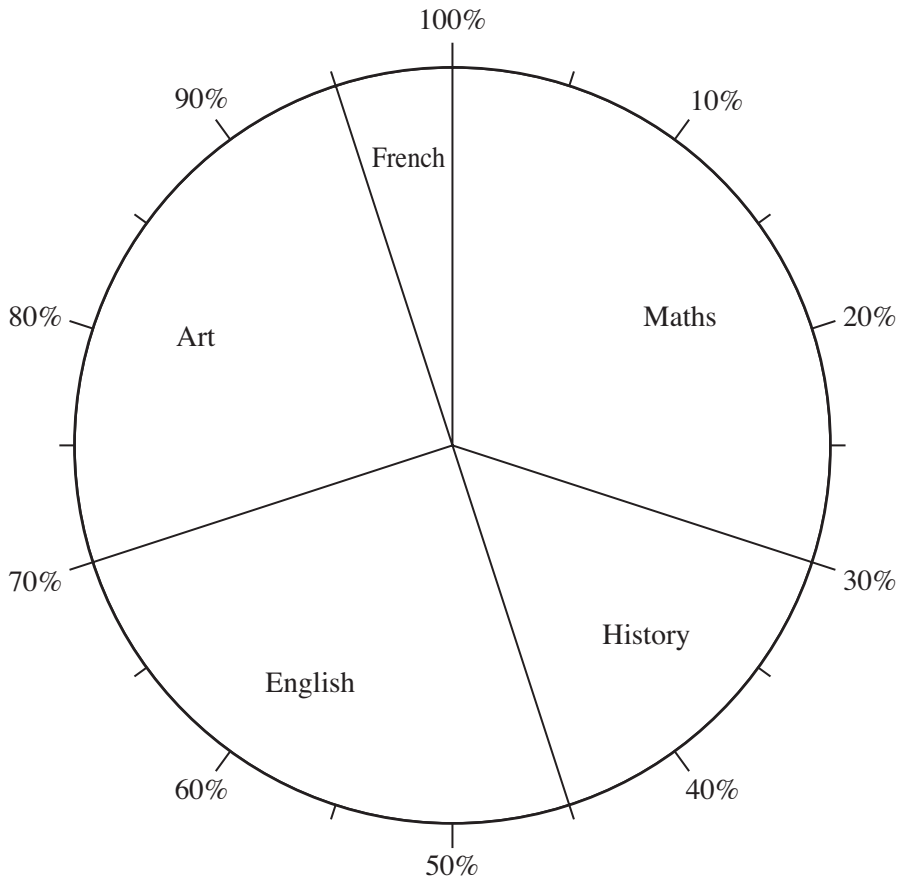

- (a) Which subject was chosen the most?

(a) ..... [1]

- (b) What percentage of the students chose Art?

(b) .....% [1]

- (c) Complete the sentence below.

Three times as many students chose ..... as French. [1]

- (d) Henry says:

Exactly half the students chose Maths or English.

Explain why he is wrong.

.....  
 ..... [1]

14

Reflex

Acute

Right angle

Obtuse

(a) Choose from the boxes to describe the angles below.



.....



.....

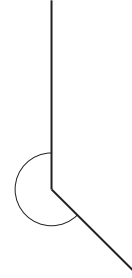

.....

[3]

(b) Measure the size of angle D.

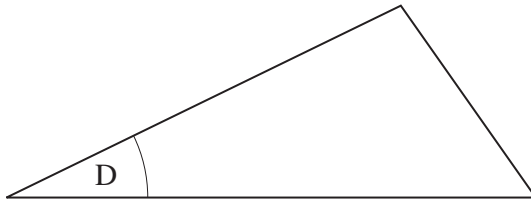

(b) .....° [1]

**TURN OVER FOR QUESTIONS 15 AND 16**

15 Haseena buys a 1 kg bag of flour.  
She uses 600 g of the flour.

How much flour is left in the bag?  
Give the units of your answer.

..... [3]

16 Bill needs 150 tiles.  
Tiles are sold in packs of 35.

(a) How many packs does he need to buy?

(a) ..... [2]

(b) How many tiles does he have left over?

(b) ..... [1]



**Copyright Information**

OCR is committed to seeking permission to reproduce all third-party content that it uses in its assessment materials. OCR has attempted to identify and contact all copyright holders whose work is used in this paper. To avoid the issue of disclosure of answer-related information to candidates, all copyright acknowledgements are reproduced in the OCR Copyright Acknowledgements Booklet. This is produced for each series of examinations, is given to all schools that receive assessment material and is freely available to download from our public website ([www.ocr.org.uk](http://www.ocr.org.uk)) after the live examination series.

If OCR has unwittingly failed to correctly acknowledge or clear any third-party content in this assessment material, OCR will be happy to correct its mistake at the earliest possible opportunity.

For queries or further information please contact the Copyright Team, First Floor, 9 Hills Road, Cambridge CB2 1PB.

OCR is part of the Cambridge Assessment Group; Cambridge Assessment is the brand name of University of Cambridge Local Examinations Syndicate (UCLES), which is itself a department of the University of Cambridge.