

**GENERAL CERTIFICATE OF SECONDARY EDUCATION**

**MATHEMATICS B (MEI)**

**B292B**

Paper 2 Section B  
(Foundation Tier)

Candidates answer on the question paper

**OCR Supplied Materials:**

None

**Other Materials Required:**

- Geometrical instruments
- Scientific or graphical calculator
- Tracing paper (optional)

**Monday 1 June 2009**  
**Morning**

**Duration: 1 hour**



Candidate Forename		Candidate Surname	
--------------------	--	-------------------	--

Centre Number						Candidate Number				
---------------	--	--	--	--	--	------------------	--	--	--	--

**INSTRUCTIONS TO CANDIDATES**

- Write your name clearly in capital letters, your Centre Number and Candidate Number in the boxes above.
- Use black ink. Pencil may be used for graphs and diagrams only.
- Read each question carefully and make sure that you know what you have to do before starting your answer.
- Show all your working. Marks may be given for a correct method even if the answer is incorrect.
- Answer **all** the questions.
- Do **not** write in the bar codes.
- Write your answer to each question in the space provided, however additional paper may be used if necessary.

**INFORMATION FOR CANDIDATES**

- The number of marks is given in brackets [ ] at the end of each question or part question.
- Section B starts with question 11.
- You are expected to use a calculator in Section B of this paper.
- Use the  $\pi$  button on your calculator or take  $\pi$  to be 3.142 unless the question says otherwise.
- The total number of marks for this Section is **50**.
- This document consists of **16** pages. Any blank pages are indicated.

## Formulae Sheet: Foundation Tier

$$\text{Area of trapezium} = \frac{1}{2} (a + b)h$$

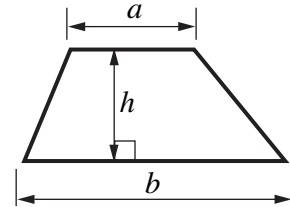

$$\text{Volume of prism} = (\text{area of cross-section}) \times \text{length}$$

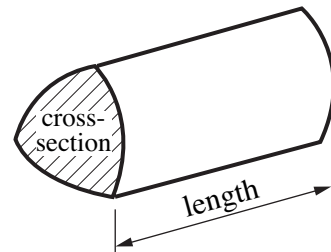

**PLEASE DO NOT WRITE ON THIS PAGE**

11 (a) Draw the reflection of the triangle in the mirror line.

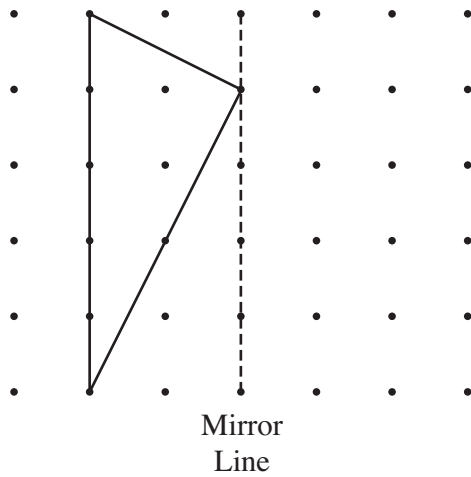

[2]

(b) Rectangle X is the reflection of rectangle Y.

Draw the mirror line.

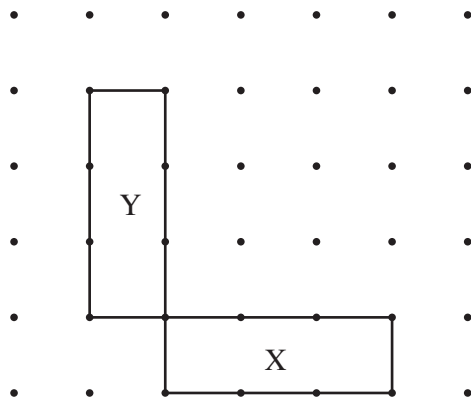

[1]

(c) Which two shapes below are congruent?

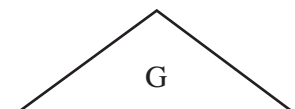
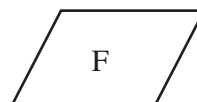
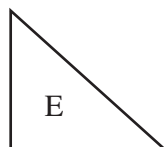
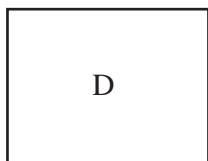
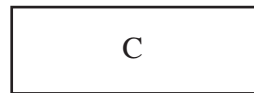
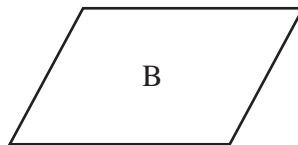
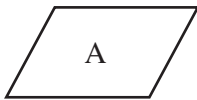

(c) ..... and ..... [1]

12 In a game, a blindfolded child sticks a pin into this picture at random.

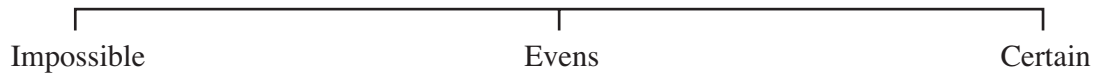
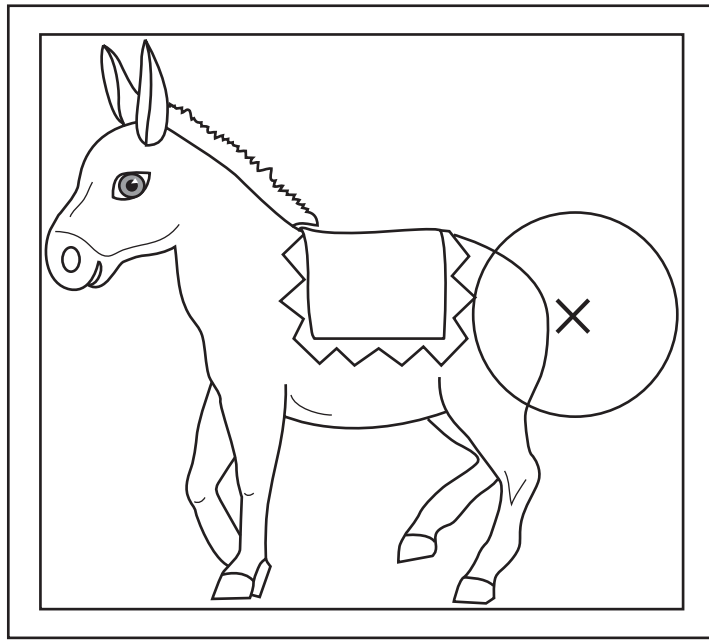

Draw an arrow on the probability line to show the probability of each of these outcomes.

- (a) The pin goes into the donkey.  
Label this arrow A. [1]
- (b) The pin goes outside the circle.  
Label this arrow B. [1]
- (c) The pin goes into the cross.  
Label this arrow C. [1]

13 For this question, **show your working** clearly in each part.

<b>Ticket prices for Deep Cave</b>	
Adult	£6.75
Child	£4.75
Group ticket (2 Adult and 2 Child) plus for each additional child	£20  £4

A party of 3 adults and 4 children visit Deep Cave.

(a) Which of these is it cheaper to buy?

- 3 adult tickets and 4 child tickets
- 2 group tickets

..... is cheaper. [3]

(b) Find a cheaper way of buying tickets for the party.

It would be cheaper to buy ..... [2]

14

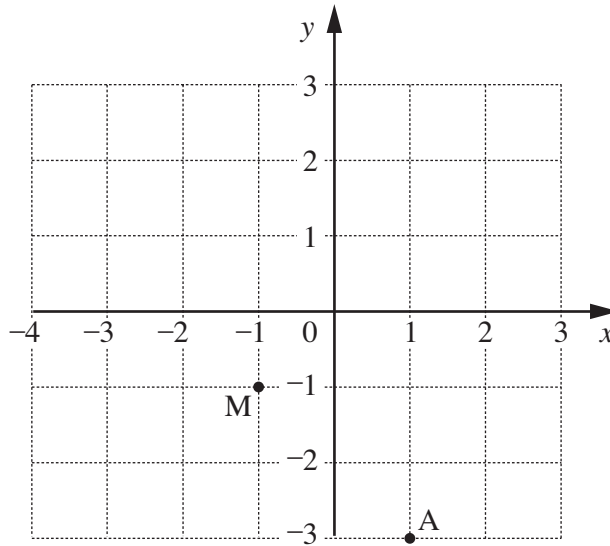

(a) Write down the coordinates of point A and point M.

(a) A(....., .....) [1]

M(....., .....) [1]

M is the midpoint of the line that joins A to another point, B.

(b) On the grid, mark the point B. [1]

15 In a school each class selects a class representative.

(a) A student is chosen at random from a class of 12 girls and 17 boys.

What is the probability that a girl is chosen?

(a) ..... [2]

(b) In another class the probability that a girl is chosen is  $\frac{18}{31}$ .

What is the probability that a boy is chosen?

(b) ..... [1]

(c) Describe a way of choosing a student at random from a class.

.....  
 ..... [2]

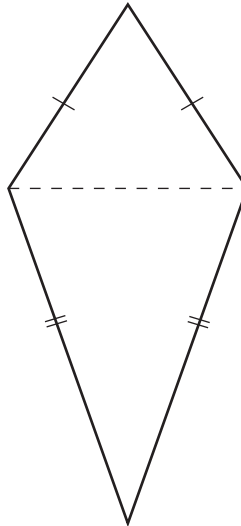

(a) Write down the mathematical name of this quadrilateral.

(a) ..... [1]

One diagonal of the quadrilateral is shown.

(b) Draw the other diagonal.

Tick the correct statement about the diagonals.

The diagonals cross at right angles.

The diagonals bisect each other.

The diagonals are of equal length. [1]

(c) Write down the mathematical name of a quadrilateral for which all three statements in part (b) are correct.

(c) ..... [1]

17

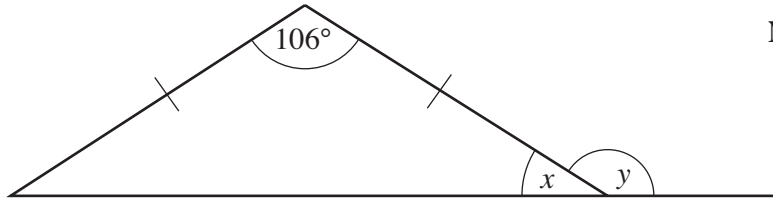

Not to scale

Calculate the following.

(a) angle  $x$

(a) .....° [2]

(b) angle  $y$

(b) .....° [1]



18 (a) (i)  $M$  represents a whole number.

What type of number is  $2M + 1$ ?

(a)(i) ..... [1]

(ii)  $N$  represents a positive number.

What type of number is  $-N$ ?

(ii) ..... [1]

(b) Here is a drawing of a butterfly net.

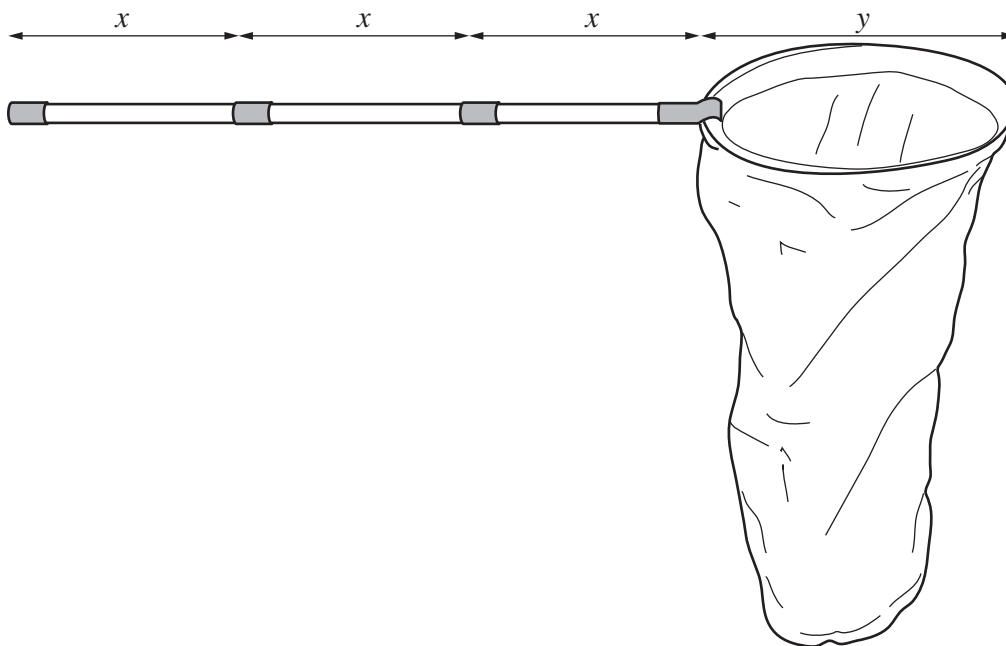

Write down an expression for the total length of the butterfly net.

(b) ..... [2]

19 (a) 2, 3 and 5 are prime numbers.

Write down two more prime numbers, each less than 20.

(a) ..... [2]

(b) Kurt notices that  $2 + 3 = 5$ . He has a theory.

**If you add two prime numbers together,  
you always get another prime number.**

Give an example to show that Kurt's theory is false.

(b) ..... + ..... = ..... which is not prime, so Kurt's theory is false. [1]

(c) Janice has a different theory.

**If you add any two prime numbers greater than 2,  
you will never get another prime number.**

Complete the proof of Janice's theory by filling in the gaps using these words.

prime	odd	even
-------	-----	------

All prime numbers greater than 2 are .....

When you add two ..... numbers your result is always .....

..... numbers are divisible by 2, so this result is not .....

[2]

20 (a) Factorise  $a^2 - 6a$ .

(a) ..... [1]

(b) Solve  $5x - 2 = 3x + 7$ .

(b) ..... [3]

(c) Simplify  $p^5 \times p^3$ .

(c) ..... [1]

- 21 John is arranging a rugby finals day.  
He asks two companies for their prices to print the programmes.

The total price is £ $y$  and the number of programmes printed is  $x$ .

- (a) Company A charges a basic fee of £200 plus an amount for each programme printed.  
The formula for Company A is  $y = 200 + 0.6x$ .

What is the amount charged for each programme printed?

(a) ..... [1]

- (b) Company B does not charge a basic fee, but charges £1.10 for each programme printed.

Write down a formula for  $y$  in terms of  $x$  for Company B.

(b) ..... [1]

(c) This graph is for  $y = 200 + 0.6x$ .

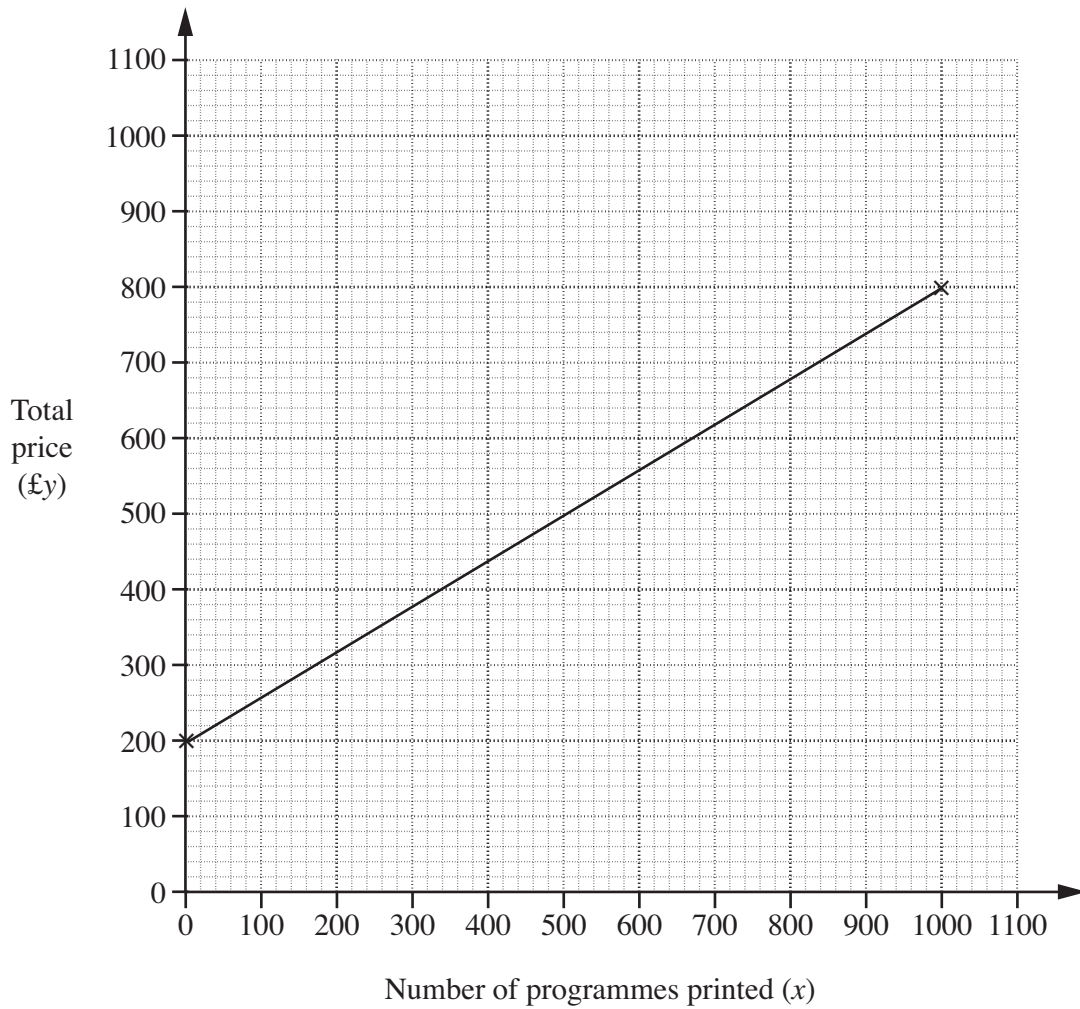

- (i) Draw a line on the grid to represent Company B's total price. [2]
- (ii) Use your graph to find the number of programmes for which the total price for the two companies is the same.

(c)(ii) ..... [2]

**TURN OVER FOR QUESTION 22**

**Discount Tiles**

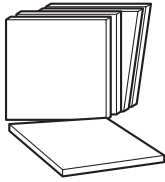

£24.35 per m<sup>2</sup>  
+ VAT

**Total Tiles**

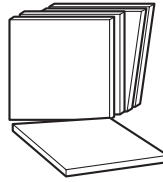

£27.73 per m<sup>2</sup>  
including VAT

VAT on tiles is charged at 17.5%.

Which shop is cheaper for the tiles after VAT is included?  
How much cheaper per m<sup>2</sup> are the tiles from this shop?

..... by £ ..... [4]

**15**  
**BLANK PAGE**

**PLEASE DO NOT WRITE ON THIS PAGE**

**PLEASE DO NOT WRITE ON THIS PAGE**



**Copyright Information**

OCR is committed to seeking permission to reproduce all third-party content that it uses in its assessment materials. OCR has attempted to identify and contact all copyright holders whose work is used in this paper. To avoid the issue of disclosure of answer-related information to candidates, all copyright acknowledgements are reproduced in the OCR Copyright Acknowledgements Booklet. This is produced for each series of examinations, is given to all schools that receive assessment material and is freely available to download from our public website ([www.ocr.org.uk](http://www.ocr.org.uk)) after the live examination series.

If OCR has unwittingly failed to correctly acknowledge or clear any third-party content in this assessment material, OCR will be happy to correct its mistake at the earliest possible opportunity.

For queries or further information please contact the Copyright Team, First Floor, 9 Hills Road, Cambridge CB2 1PB.

OCR is part of the Cambridge Assessment Group; Cambridge Assessment is the brand name of University of Cambridge Local Examinations Syndicate (UCLES), which is itself a department of the University of Cambridge.