

OXFORD CAMBRIDGE AND RSA EXAMINATIONS
General Certificate of Secondary Education
MATHEMATICS SYLLABUS A

1962/6

PAPER 6 (Higher Tier)

Monday **12 JUNE 2006** Morning 2 hours

Candidates answer on the question paper.

Additional materials:

- Electronic Calculator
- Geometrical instruments
- Tracing paper (optional)

Candidate Name	Centre Number	Candidate Number												
	<table border="1" style="display: inline-table; border-collapse: collapse;"> <tr> <td style="width: 15px; height: 15px;"></td> <td style="width: 15px; height: 15px;"></td> <td style="width: 15px; height: 15px;"></td> <td style="width: 15px; height: 15px;"></td> <td style="width: 15px; height: 15px;"></td> <td style="width: 15px; height: 15px;"></td> </tr> </table>							<table border="1" style="display: inline-table; border-collapse: collapse;"> <tr> <td style="width: 15px; height: 15px;"></td> <td style="width: 15px; height: 15px;"></td> <td style="width: 15px; height: 15px;"></td> <td style="width: 15px; height: 15px;"></td> <td style="width: 15px; height: 15px;"></td> <td style="width: 15px; height: 15px;"></td> </tr> </table>						

TIME 2 hours

INSTRUCTIONS TO CANDIDATES

- Write your name in the space above.
- Write your Centre number and candidate number in the boxes above.
- Answer **all** the questions.
- Write your answers, in blue or black ink, in the spaces provided on the question paper.
- Read each question carefully and make sure you know what you have to do before starting your answer.
- Show your working. Marks may be given for working that shows that you know how to solve the problem even if you get the answer wrong.
- You are expected to use an electronic calculator for this paper.

INFORMATION FOR CANDIDATES

- The number of marks is given in brackets [] at the end of each question or part question.
- Unless otherwise instructed in the question, take π to be 3.142 or use the π button on your calculator.

FOR EXAMINER'S USE

This question paper consists of 19 printed pages and 1 blank page.

Formulae Sheet: Higher Tier

Volume of prism = (area of cross-section) x length

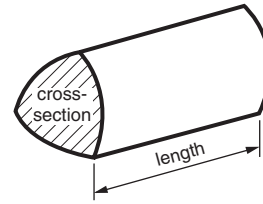

In any triangle ABC

Sine rule $\frac{a}{\sin A} = \frac{b}{\sin B} = \frac{c}{\sin C}$

Cosine rule $a^2 = b^2 + c^2 - 2bc \cos A$

Area of triangle = $\frac{1}{2} ab \sin C$

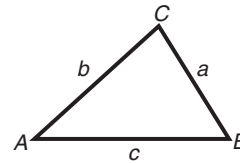

Volume of sphere = $\frac{4}{3} \pi r^3$

Surface area of sphere = $4\pi r^2$

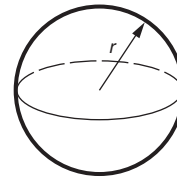

Volume of cone = $\frac{1}{3} \pi r^2 h$

Curved surface area of cone = $\pi r l$

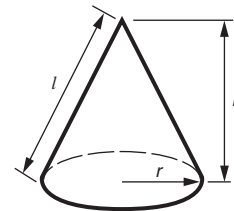

The Quadratic Equation

The solutions of $ax^2 + bx + c = 0$
where $a \neq 0$, are given by

$$x = \frac{-b \pm \sqrt{(b^2 - 4ac)}}{2a}$$

1 Use your calculator to work these out.

(a) $\sqrt{\frac{100}{2.7^3}}$

Give your answer correct to two significant figures.

.....

(a) _____ [2]

(b) $5\frac{3}{5} \div 1\frac{3}{4}$

Give your answer as a fraction.

.....

(b) _____ [2]

(c) $(5.4 \times 10^8) + (6.2 \times 10^9)$

Give your answer in standard form.

.....

(c) _____ [2]

- 2 (a) When 150 cm^3 of water freezes, 162 cm^3 of ice is formed.

Calculate the percentage increase in the volume.

.....
.....
.....
.....

(a) _____ % [3]

- (b) The volume of a large cake is 6708 cm^3 .
This volume is an increase of 72% of the uncooked mixture.

Calculate the volume of the uncooked mixture.

.....
.....
.....
.....

(b) _____ cm^3 [3]

3

5

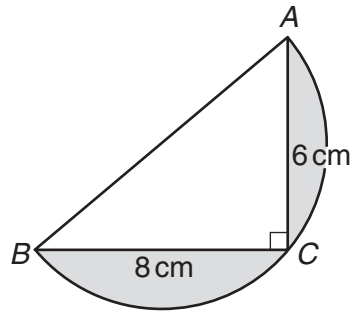

NOT TO
SCALE

The diagram shows part of a circle, radius 5 cm, with points A , B and C on the edge. $AC = 6$ cm, $BC = 8$ cm and angle $C = 90^\circ$.

(a) Explain how you can tell that AB is the diameter of the circle.

.....
.....

AB is the diameter because _____

_____ [2]

(b) Calculate the total shaded area.
Give the units of your answer.

.....
.....
.....
.....
.....

(b) _____ [6]

- 4 Use trial and improvement to find the value of x correct to **one** decimal place when

$$x^3 - 4x = 24.$$

You must show all your trials and their outcomes.

.....

.....

.....

.....

.....

.....

.....

.....

_____ [4]

- 5 (a) Hassan measured the heights of 80 boys from Year 11. His results are summarised in the table below.

Height (h cm)	Frequency
$150 < h \leq 160$	8
$160 < h \leq 170$	40
$170 < h \leq 180$	28
$180 < h \leq 190$	4

Calculate an estimate of the mean height.

.....

.....

.....

.....

.....

(a) _____ cm [4]

(b) The cumulative frequency diagram below shows the heights of 80 girls from Year 11.

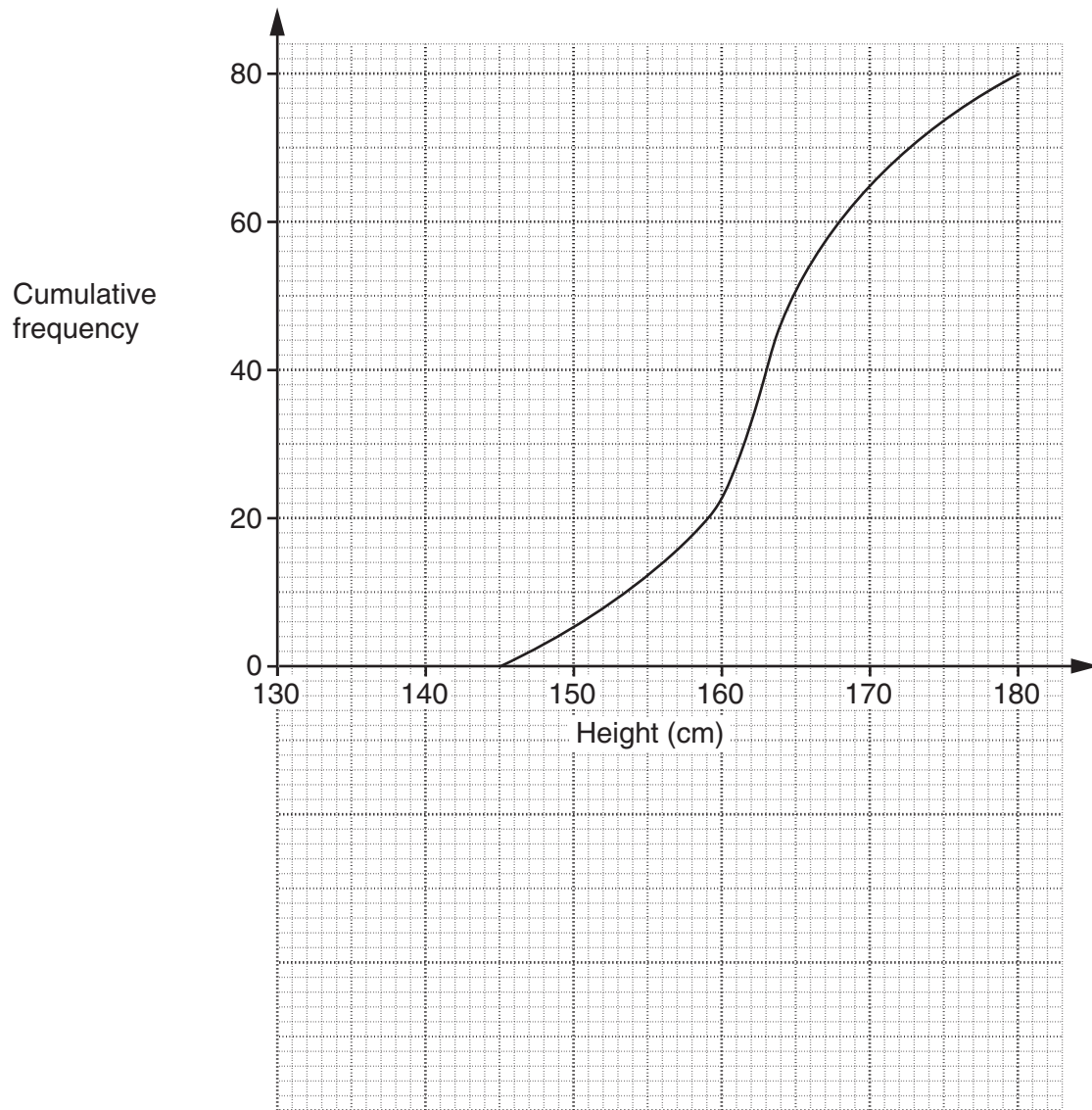

On the grid, below the cumulative frequency diagram, draw a box plot to illustrate the distribution of the heights of the girls. [3]

6 (a)

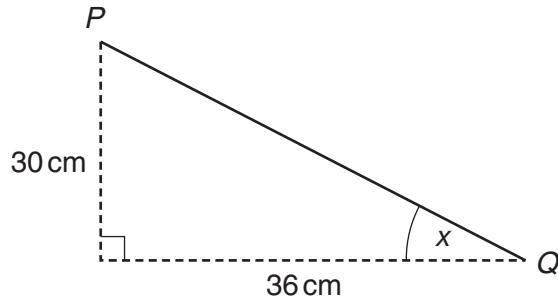

NOT TO
SCALE

A handrail, PQ , makes an angle x with the horizontal.

Calculate angle x .

.....

.....

.....

(a) _____° [3]

(b)

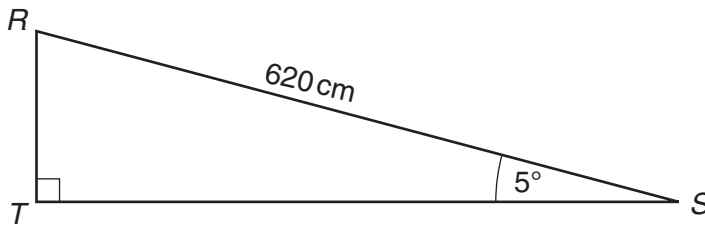

NOT TO
SCALE

Some steps are replaced by a ramp, RS .

The ramp measures 620 cm and makes an angle of 5° with the horizontal.

Calculate RT .

.....

.....

.....

.....

(b) _____ cm [3]

7 (a) Multiply out.

$$x(x^2 + 3)$$

.....

(a) _____ [2]

(b) Multiply out and simplify completely.

$$2(x + 3) + 3(2x - 1)$$

.....

(b) _____ [2]

(c) Solve.

$$\frac{x - 15}{2} = 3 - x$$

.....

.....

.....

.....

.....

.....

(c) _____ [3]

8

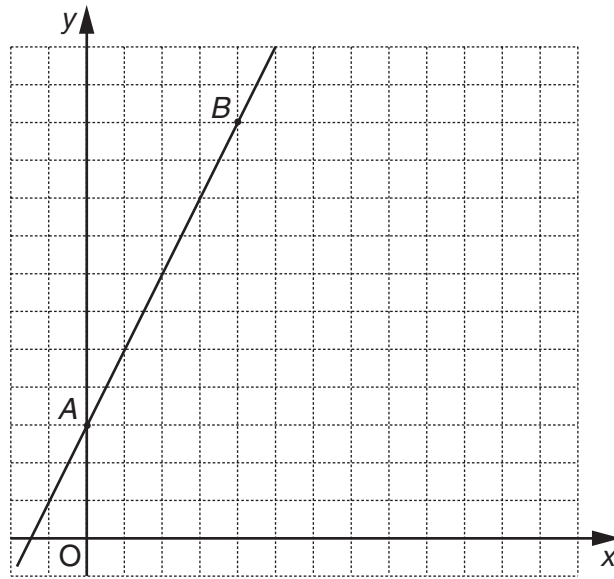

A straight line is drawn through the points $A(0, 3)$ and $B(4, 11)$.

(a) (i) Work out the gradient of AB .

.....

(a)(i) _____ [2]

(ii) Write down the equation of the line AB .

(ii) _____ [1]

(b) Write down the equation of the line parallel to AB which passes through the point $(0, 0)$.

.....

(b) _____ [1]

9

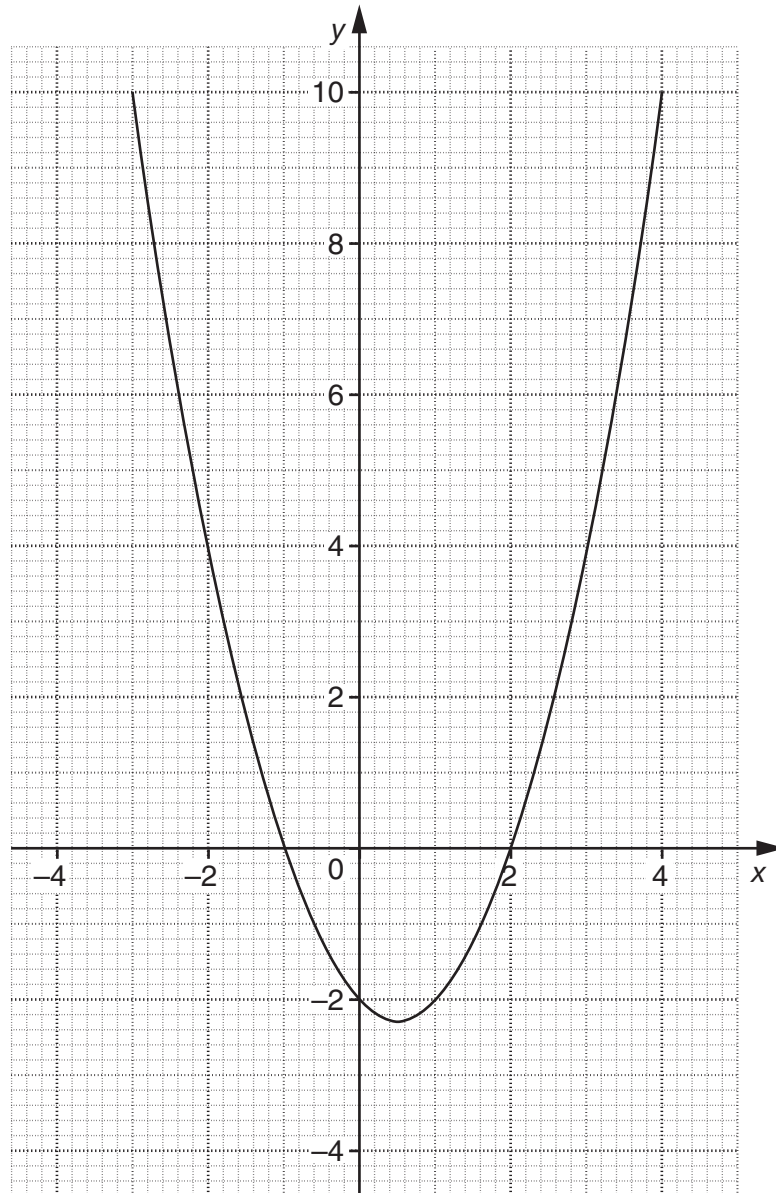

Part of the graph of $y = x^2 - x - 2$ is drawn on the grid above.

- (a) Draw the line $y = 3$ on the grid.
What are the values of x where the line $y = 3$ crosses the curve?

(a) _____ [2]

- (b) By drawing a suitable straight line on the grid solve the equation

$$x^2 - x - 2 = 2 - 2x.$$

(b) _____ [3]

10

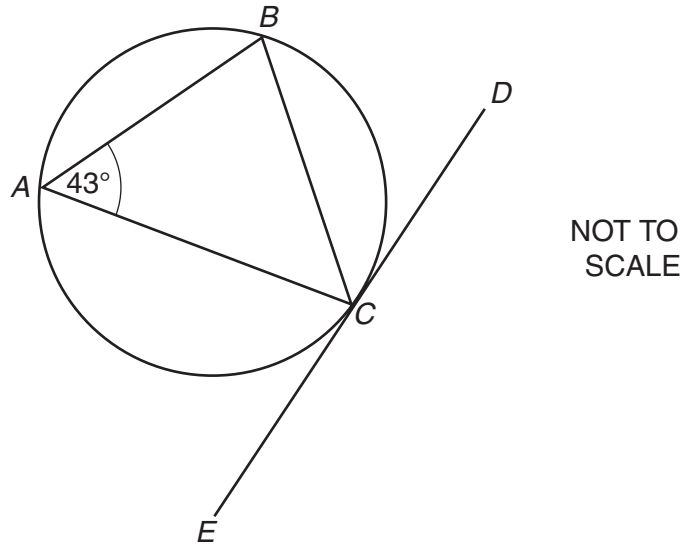

A , B and C are points on the circle.
 ECD is the tangent at C .
Angle $BAC = 43^\circ$.

Prove that angle $BCE = 137^\circ$.
Give a reason for each step of your proof.

[3]

- 11 When a stone is dropped, its speed, v , is proportional to the **square root** of the distance, d , it has fallen.

$$v = 14 \text{ ms}^{-1} \text{ when } d = 10 \text{ m.}$$

- (a) Find the formula for v in terms of d .

.....
.....
.....
.....
.....
.....

(a) _____ [3]

- (b) Calculate the distance the stone has fallen when its speed is 28 ms^{-1} .

.....
.....
.....
.....
.....
.....

(b) _____ m [2]

12

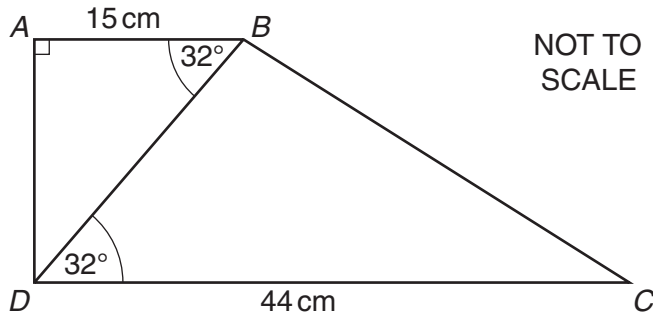

ABCD is a trapezium.
 Angle *BAD* = 90° .
 Angle *BDC* = angle *ABD* = 32°
AB = 15 cm and *DC* = 44 cm.

Calculate the length of *BC*.

Give your answer to a suitable degree of accuracy.

.....

.....

.....

.....

.....

.....

.....

.....

.....

.....

_____ cm [6]

13

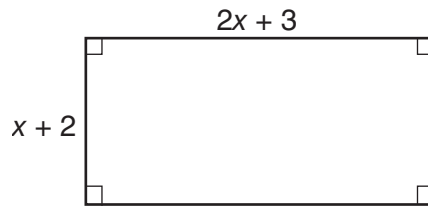
NOT TO
SCALE

The lengths of the sides of this rectangle are given in metres.
The area of the rectangle is 36 m^2 .

(a) Form an equation in x and show that it simplifies to

$$2x^2 + 7x - 30 = 0.$$

[3]

(b) Solve the equation

$$2x^2 + 7x - 30 = 0.$$

(b) _____ [3]

14

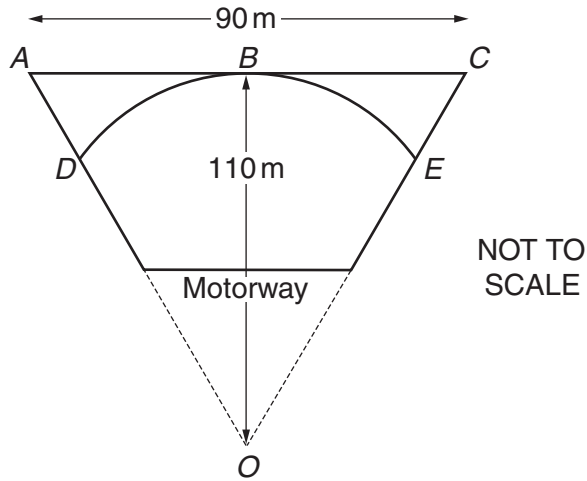

The diagram represents a horizontal bridge ABC over a motorway.

DBE is an arc of a circle with centre O .
 AC is the tangent to the circle at B .
 $AC = 90$ m and the radius, OB , of the circle is 110 m.
Triangle AOC is isosceles.

Calculate the length of the arc DBE .

.....

.....

.....

.....

.....

.....

.....

.....

.....

.....

_____ m [5]

- 15 A florist buys rolls of ribbon to make bows for decorating bouquets of flowers.
The length of ribbon on each roll is 145 m, correct to the nearest metre.
The length of ribbon she uses for each bow is 1.2 m correct to one decimal place.

Calculate the greatest number of bows she could possibly make from one roll.

.....

.....

.....

.....

.....

.....

.....

.....

.....

_____ [5]

- 16 Rationalise the denominator of this fraction.

$$\frac{10}{\sqrt{5}}$$

Give your answer in the form $a\sqrt{b}$ where a and b are integers.

.....

.....

.....

_____ [2]

17

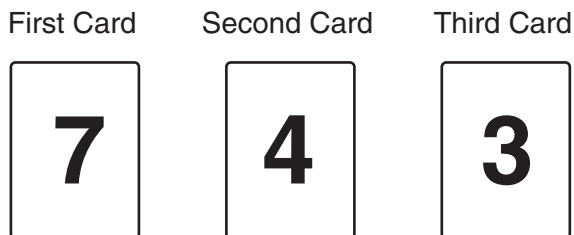

Seven cards, numbered **1, 2, 3, 4, 5, 7** and **9**, are thoroughly shuffled and placed face down. A person selects three cards and turns them over, placing them side by side to form a three digit number.

(a) What is the probability that the number formed is **743**?

Give your answer as a fraction.

.....

.....

.....

(a) _____ [2]

(b) What is the probability that the three digits are **all odd** numbers?

Give your answer as a fraction in its lowest terms.

.....

.....

.....

(b) _____ [3]

(c) What is the probability that the number is **greater than 700** and also **even**?

Give your answer as a fraction in its lowest terms.

.....

.....

.....

(c) _____ [3]

18 (a) Simplify.

$$\frac{x^2 - 3x}{x^2 - 6x + 9}$$

.....

.....

.....

.....

.....

.....

(a) _____ [3]

(b) (i) Find a and b when

$$x^2 + 8x + 21 = (x + a)^2 + b.$$

.....

.....

.....

.....

.....

(b)(i) $a =$ _____ $b =$ _____ [3]

(ii) Use your answer to (b)(i) to find the minimum value of

$$x^2 + 8x + 21.$$

.....

.....

.....

(ii) _____ [1]

