

Candidate forename		Candidate surname	
-----------------------	--	----------------------	--

Centre number						Candidate number				
------------------	--	--	--	--	--	---------------------	--	--	--	--

**OXFORD CAMBRIDGE AND RSA EXAMINATIONS
GCSE**

A501/02

MATHEMATICS A

Unit A (Higher Tier)

THURSDAY 19 JANUARY 2012: Afternoon

DURATION: 1 hour

SUITABLE FOR VISUALLY IMPAIRED CANDIDATES

Candidates answer on the Question Paper.

OCR SUPPLIED MATERIALS:

None

OTHER MATERIALS REQUIRED:

Scientific or graphical calculator

Geometrical instruments

Tracing paper (optional)

<p>You are permitted to use a calculator for this paper.</p>

This paper has been pre modified for carrier language

READ INSTRUCTIONS OVERLEAF

INSTRUCTIONS TO CANDIDATES

- **Write your name, centre number and candidate number in the boxes on the first page. Please write clearly and in capital letters.**
- **Use black ink. HB pencil may be used for graphs and diagrams only.**
- **Answer ALL the questions.**
- **Read each question carefully. Make sure you know what you have to do before starting your answer.**
- **Your answers should be supported with appropriate working. Marks may be given for a correct method even if the answer is incorrect.**
- **Write your answer to each question in the space provided. Additional paper may be used if necessary but you must clearly show your candidate number, centre number and question number(s).**

INFORMATION FOR CANDIDATES

- **The number of marks is given in brackets [] at the end of each question or part question.**
- **The total number of marks for this paper is 60.**

FORMULAE SHEET: HIGHER TIER

Area of trapezium = $\frac{1}{2}(a + b)h$

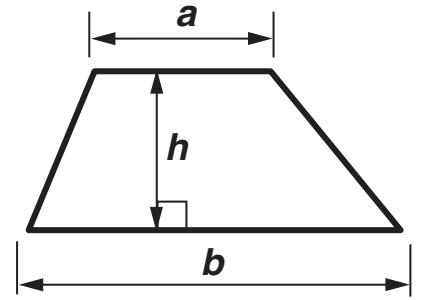

Volume of prism = (area of cross-section) \times length

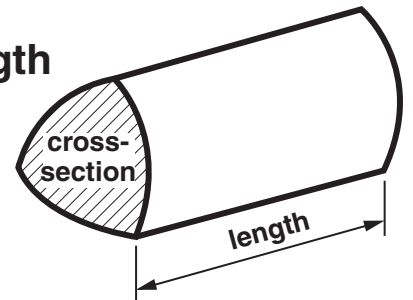

In any triangle ABC

Sine rule $\frac{a}{\sin A} = \frac{b}{\sin B} = \frac{c}{\sin C}$

Cosine rule $a^2 = b^2 + c^2 - 2bc \cos A$

Area of triangle = $\frac{1}{2} ab \sin C$

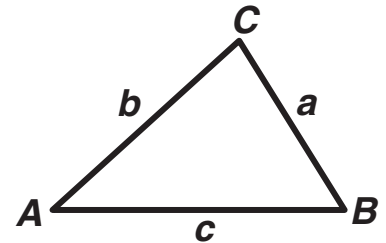

Volume of sphere = $\frac{4}{3} \pi r^3$

Surface area of sphere = $4\pi r^2$

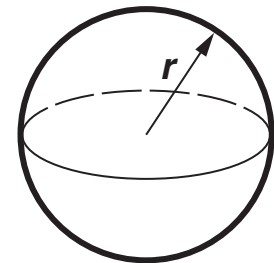

Volume of cone = $\frac{1}{3} \pi r^2 h$

Curved surface area of cone = $\pi r l$

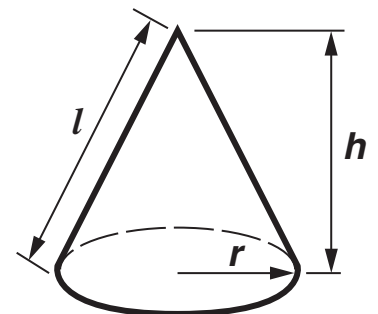

The Quadratic Equation

The solutions of $ax^2 + bx + c = 0$, where $a \neq 0$, are given by

$$x = \frac{-b \pm \sqrt{(b^2 - 4ac)}}{2a}$$

**1 Margie makes blackberry and apple jam.
Her recipe uses 2 kg of blackberries and 750 g of
apples.
This makes 6 jars of jam.**

**(a) Show that the ratio of blackberries to apples, in its
simplest terms, is 8 : 3.
Explain clearly how you obtain the answer.**

[2]

**(b) Margie has 3 kg of blackberries.
She uses them all to make blackberry and apple
jam.**

**(i) What weight of apples does she use?
Give the units of your answer.**

(b)(i) _____ [3]

(ii) How many jars of the jam does she make?

(ii) _____ [1]

2 Find the prime factors of 102.

_____ **[2]**

- 3 This is a scale drawing showing the position of two airports, A and B.
The scale is 1 cm represents 50 km.**

B.



SCALE: 1 cm REPRESENTS 50 km

**An aircraft flies from airport A to airport C.
C is 360 km from A on a bearing of 247° .**

**(a) On the scale drawing, construct the position of
airport C. [2]**

(b) Find the actual distance of airport C from airport B.

(b) _____ km [2]

4 (a) Solve.

$$3(2x - 1) = 6$$

(a) _____ **[3]**

(b) Find the value of $3y^2 + 5$ when

(i) $y = 2.6$,

(b)(i) _____ **[1]**

(ii) $y = -4.$

(ii) _____ [1]

5 (a) These are the first three terms of a sequence.

5 10 20

Here is the term-to-term rule for this sequence.

multiply by 2

The number 1280 is in this sequence.

Find the position of this number in the sequence.

(a) 1280 is the _____ th term [2]

(b) The first term of another sequence is 4.

Here is the term-to-term rule for this sequence.

add 7

(i) Find the second and third terms of this sequence.

(b)(i) _____ [1]

(ii) Find an expression for the n th term of this sequence.

(ii) _____ [2]

- 6 Dave is building a greenhouse.
The base measures 2.57 m by 1.93 m.

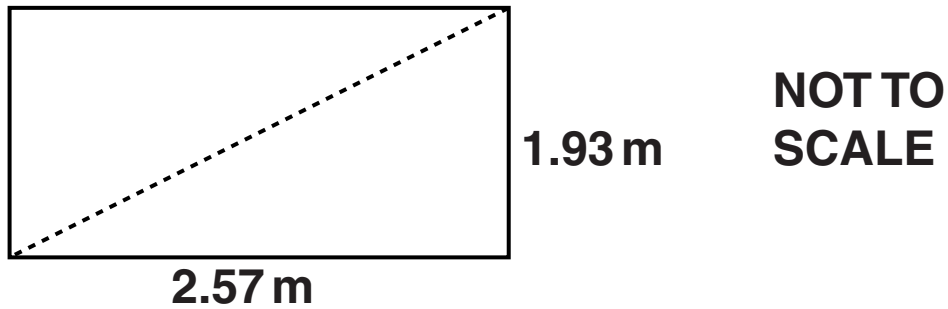

Dave checks that the base is a rectangle by measuring the diagonals.

Calculate the length that a diagonal should be.

_____ m [3]

BLANK PAGE

7 In a lift there is this sign.

<p>Maximum 8 people</p> <p>Maximum total weight 550 kg</p>

There are 7 people in the lift.

Their mean weight is 65.4 kg.

Another person who weighs 85 kg gets in the lift.

(a) Has the maximum total weight for the lift been exceeded?

Show calculations to support your answer.

[3]

(b) Find the mean weight of all 8 people.

(b) _____ kg [2]

8 Calculate.

(a) $\sqrt[3]{21.952^2}$

(a) _____ [2]

(b) $\frac{15.6 + 81.97}{4.3 \times 9.84}$

Give your answer correct to 2 decimal places.

(b) _____ [2]

(c) the reciprocal of 1.25

(c) _____ [1]

- 9 In T20 cricket, the number of runs per over scored by a team is important.

This table summarises the number of runs per over scored by team A in its matches in one season.

Minimum	4.2
Lower quartile	5.1
Median	7.6
Upper quartile	8.4
Maximum	10.1

- (a) Draw a box plot for this information.

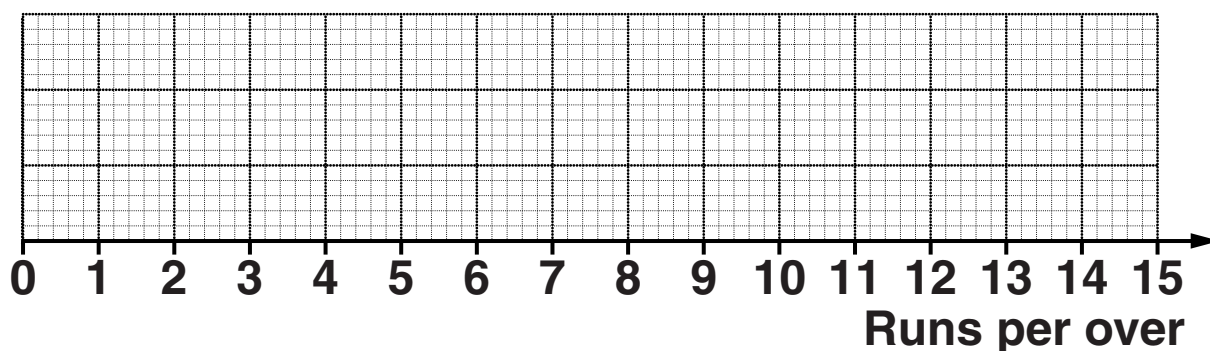

[3]

**(b) Here is a cumulative frequency diagram.
It gives information about the runs per over
scored by team A's opponents in 30 matches.**

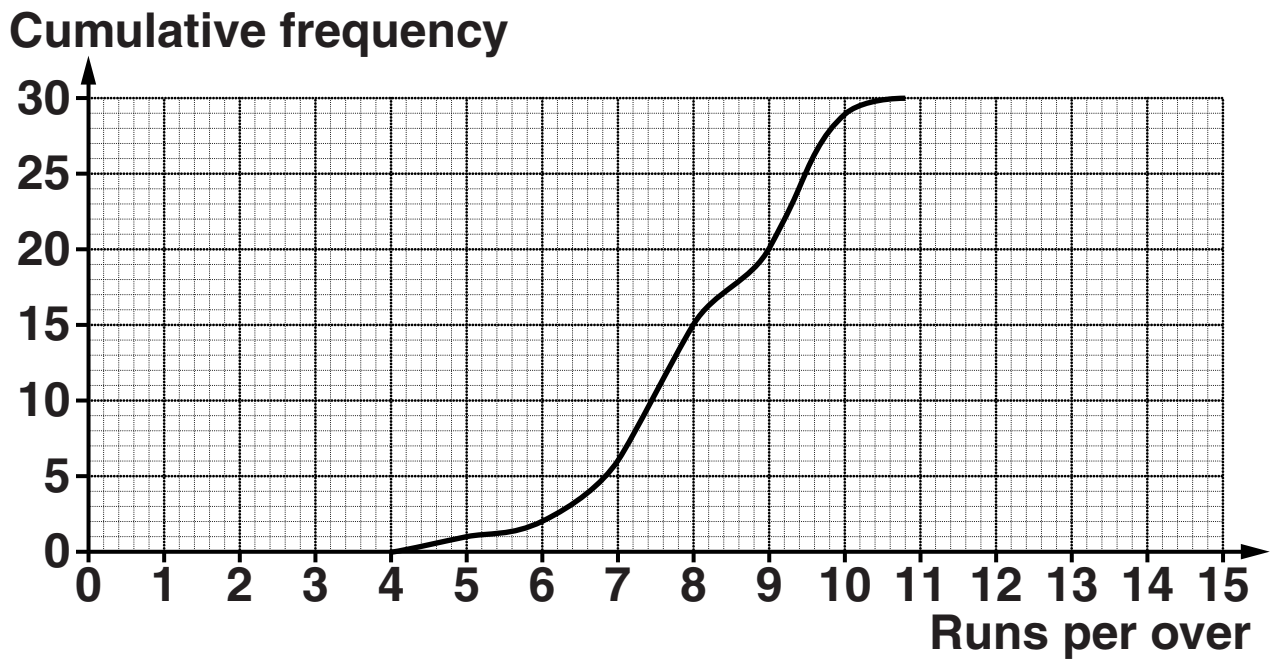

- (i) In how many matches did team A's opponents score 6 runs or less per over?

(b)(i) _____ [1]

- (ii) Make two comments comparing the number of runs per over scored by team A and by its opponents.
Give numerical evidence for the statistics you use.

Average: _____

Spread: _____

_____ [4]

**10 Use a ruler and a pair of compasses in this question.
Do not rub out your construction lines.**

**Construct the perpendicular from the point P to the
line AB.**

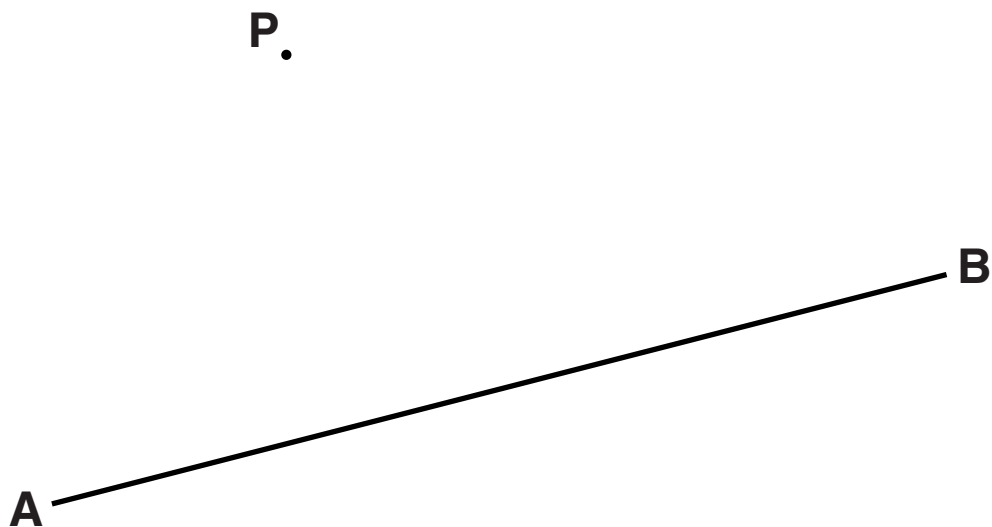

[2]

11 (a) Rearrange this formula to make r the subject.

$$S = 4\pi r^2$$

(a) _____ [3]

(b) $f(x) = \frac{3}{4x + 6}$

(i) Find $f(1)$.

(b)(i) _____ [1]

(ii) Explain why $f(-1.5)$ cannot be evaluated. [1]

12 (a) Find the values of a and b so that this is an identity.

$$5x + 3(x + 1) \equiv ax + b$$

(a) $a =$ _____

$b =$ _____ [2]

(b) Find possible values of c and d so that this is an equation with the solution $x = 2$.

$$5x + 3(x + 1) = cx + d$$

(b) $c =$ _____

$d =$ _____ **[2]**

- 13 ABCD is a quadrilateral.
Angles BAD and DBC are both right angles.
Angles ABD and BCD are both 35° .
AB = 6.5 cm.

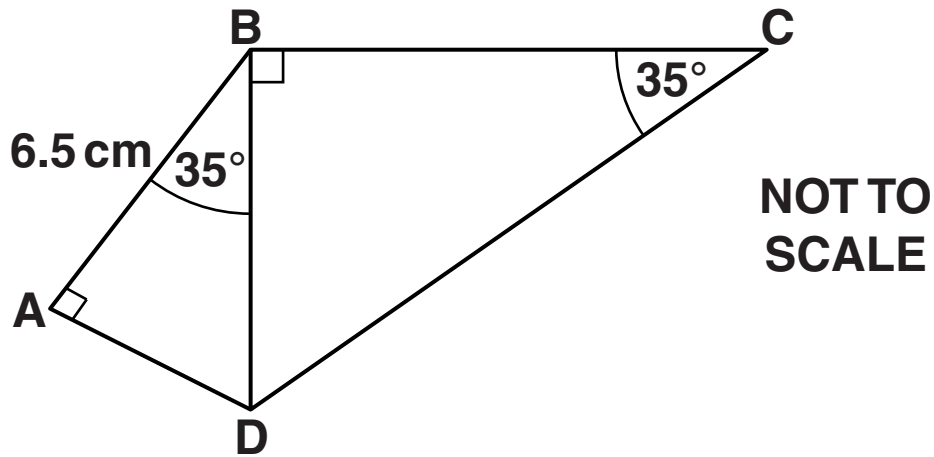

Calculate the length of CD.

_____ cm [6]

Copyright Information

OCR is committed to seeking permission to reproduce all third-party content that it uses in its assessment materials. OCR has attempted to identify and contact all copyright holders whose work is used in this paper. To avoid the issue of disclosure of answer-related information to candidates, all copyright acknowledgements are reproduced in the OCR Copyright Acknowledgements Booklet. This is produced for each series of examinations and is freely available to download from our public website (www.ocr.org.uk) after the live examination series.

If OCR has unwittingly failed to correctly acknowledge or clear any third-party content in this assessment material, OCR will be happy to correct its mistake at the earliest possible opportunity.

For queries or further information please contact the Copyright Team, First Floor, 9 Hills Road, Cambridge CB2 1GE.

OCR is part of the Cambridge Assessment Group; Cambridge Assessment is the brand name of University of Cambridge Local Examinations Syndicate (UCLES), which is itself a department of the University of Cambridge.