

Candidate forename		Candidate surname	
-----------------------	--	----------------------	--

Centre number						Candidate number				
------------------	--	--	--	--	--	---------------------	--	--	--	--

**OXFORD CAMBRIDGE AND RSA EXAMINATIONS  
GCSE**

**J512/01**

**MATHEMATICS SYLLABUS A**

**Paper 1 (Foundation Tier)**

**WEDNESDAY 11 JANUARY 2012: Morning**

**DURATION: 2 hours**

**SUITABLE FOR VISUALLY IMPAIRED CANDIDATES**

**Candidates answer on the Question Paper.**

**OCR SUPPLIED MATERIALS:**

**None**

**OTHER MATERIALS REQUIRED:**

**Geometrical instruments**

**Tracing paper (optional)**

<p><b><u>WARNING</u></b> <b>No calculator can be used for this paper.</b></p>
---

**This paper has been pre modified for carrier language**

**READ INSTRUCTIONS OVERLEAF**

## **INSTRUCTIONS TO CANDIDATES**

- **Write your name, centre number and candidate number in the boxes on the first page. Please write clearly and in capital letters.**
- **Use black ink. HB pencil may be used for graphs and diagrams only.**
- **Answer ALL the questions.**
- **Read each question carefully. Make sure you know what you have to do before starting your answer.**
- **Show your working. Marks may be given for a correct method even if the answer is incorrect.**
- **Write your answer to each question in the space provided. Additional paper may be used if necessary but you must clearly show your candidate number, centre number and question number(s).**

## **INFORMATION FOR CANDIDATES**

- **The number of marks is given in brackets [ ] at the end of each question or part question.**
- **The total number of marks for this paper is 100.**

# FORMULAE SHEET: FOUNDATION TIER

Area of trapezium =  $\frac{1}{2}(a + b)h$

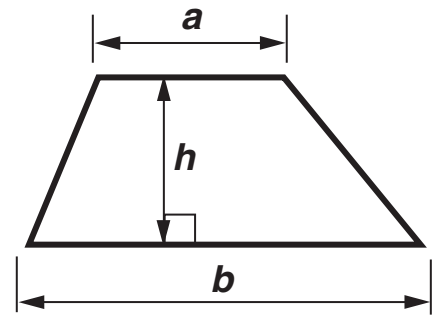

Volume of prism = (area of cross-section)  $\times$  length

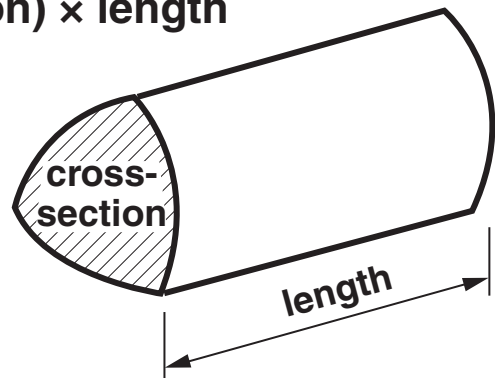

**1 Use the numbers in the box below, to answer the questions which follow.**

<b>25</b>	<b>3</b>	<b>105</b>	<b>23</b>
<b>62</b>	<b>7</b>		
<b>4</b>	<b>40</b>	<b>57</b>	<b>10</b>

**(a) the smallest odd number,**

**(a)** \_\_\_\_\_ **[1]**

**(b) an even number bigger than 50,**

**(b)** \_\_\_\_\_ **[1]**

**(c) a factor of 35,**

**(c)** \_\_\_\_\_ **[1]**

**(d) a multiple of 20,**

**(d)** \_\_\_\_\_ **[1]**

**(e) two numbers with a total of 80,**

---

---

**(e)** \_\_\_\_\_ **[1]**

**(f) two numbers that multiply together to give 100.**

---

---

**(f)** \_\_\_\_\_ **[1]**

2 (a) Write the mathematical name of the 3-D shapes below, that have these nets. Choose from the list in the box.

- |                             |                        |
|-----------------------------|------------------------|
| <b>Square-based pyramid</b> | <b>Cuboid</b>          |
| <b>Cylinder</b>             | <b>Sphere</b>          |
| <b>Cone</b>                 | <b>Cube</b>            |
| <b>Triangular prism</b>     | <b>Hexagonal prism</b> |

(i)

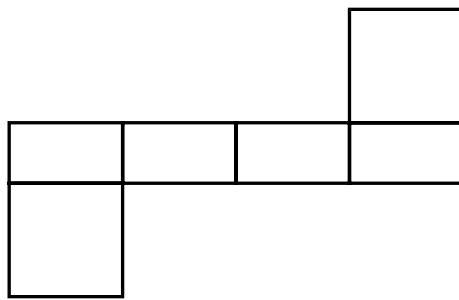

(a)(i) \_\_\_\_\_ [1]

(ii)

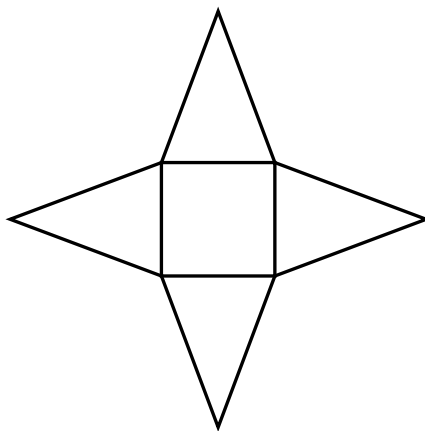

(ii) \_\_\_\_\_ [1]

**(iii)**



**(iii)** \_\_\_\_\_ **[1]**

**(b) Draw the reflection of this shape in the mirror line.**

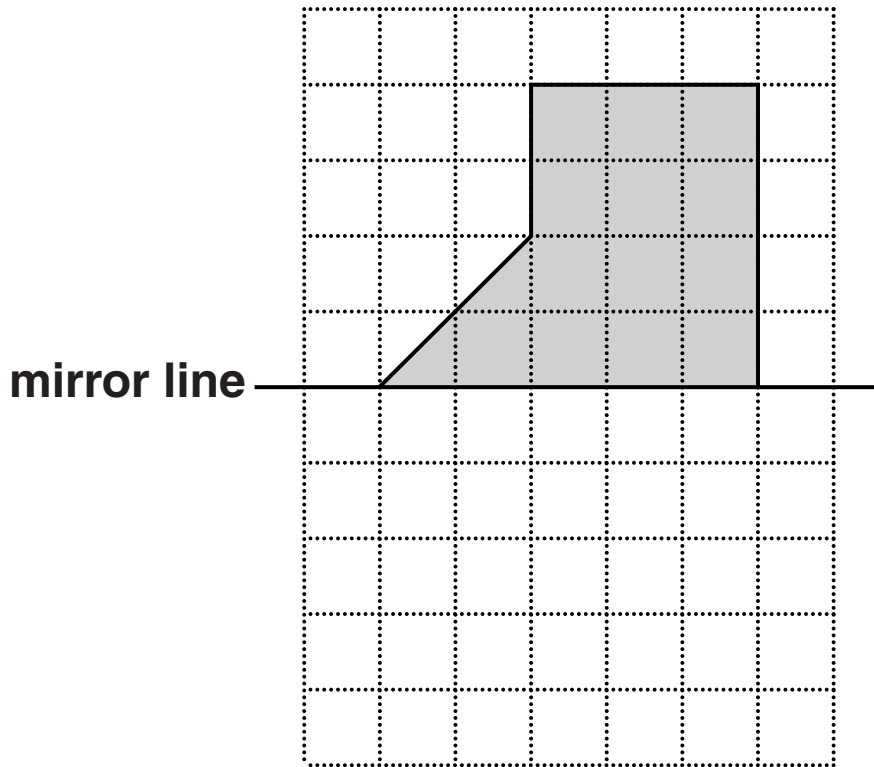

**[2]**

**(c) Look at the shapes below.**

**Put a tick (✓) in each of the TWO shapes that are CONGRUENT.**

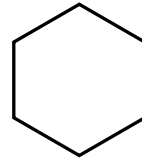
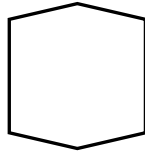
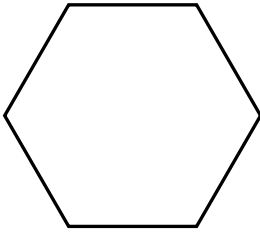
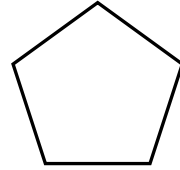
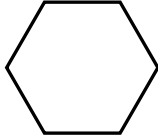

**[1]**



**3 Chose from these five events to complete the sentences below.**

**Write the appropriate letter in the space.**

<b>A</b>	<b>It will snow during the winter.</b>
<b>B</b>	<b>My dog will pass GCSE maths.</b>
<b>C</b>	<b>It will rain every day next week.</b>
<b>D</b>	<b>An ordinary dice will show a 1, 2, 3, 4, 5 or 6.</b>
<b>E</b>	<b>An ordinary dice will show an even number.</b>

**(a) Event \_\_\_\_\_ is impossible. [1]**

**(b) Event \_\_\_\_\_ is likely to happen. [1]**

**(c) Event \_\_\_\_\_ is certain to happen. [1]**

**(d) Event \_\_\_\_\_ has a fifty-fifty chance of happening. [1]**

4 (a) Write as a decimal.

(i)  $\frac{1}{4}$

(a)(i) \_\_\_\_\_ [1]

(ii) 30%

(ii) \_\_\_\_\_ [1]

(b) Write these numbers in order of size, starting with the smallest.

$\frac{1}{4}$

30%

0.2

---

---

(b) \_\_\_\_\_ *smallest* \_\_\_\_\_ [1]

- 5 (a) (i) Write down the two missing numbers in this sequence.

5      \_\_\_\_\_      19      26      33      \_\_\_\_\_ [2]

- (ii) Write down the rule for your sequence.

\_\_\_\_\_  
\_\_\_\_\_ [1]

- (b) A different sequence is made using this rule.

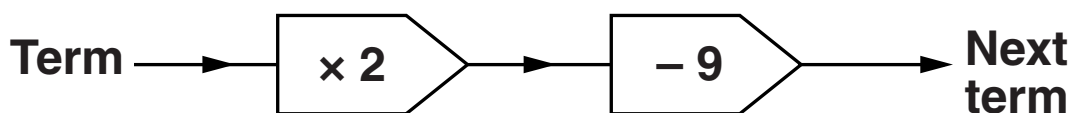

The first term of the sequence is 9.

- (i) Write down the second term of the sequence.

\_\_\_\_\_  
\_\_\_\_\_

(b)(i) \_\_\_\_\_ [1]

- (ii) Write down the 50th term of the sequence.

\_\_\_\_\_  
\_\_\_\_\_

(ii) \_\_\_\_\_ [1]

**BLANK PAGE**

**6 (a) What is the value of the 7 in the number 17238?**

**(a)** \_\_\_\_\_ **[1]**

**(b) What is the value of the 3 in the number 17.34?**

**(b)** \_\_\_\_\_ **[1]**

**(c) What is the value of the 2 in the ANSWER to  $32 \times 100$ ?**

\_\_\_\_\_  
\_\_\_\_\_

**(c)** \_\_\_\_\_ **[1]**

**(d) What is the value of the 9 in the ANSWER to  $7913 \div 100$ ?**

\_\_\_\_\_  
\_\_\_\_\_

**(d)** \_\_\_\_\_ **[1]**

7 Use the grid below, to answer the questions which follow.

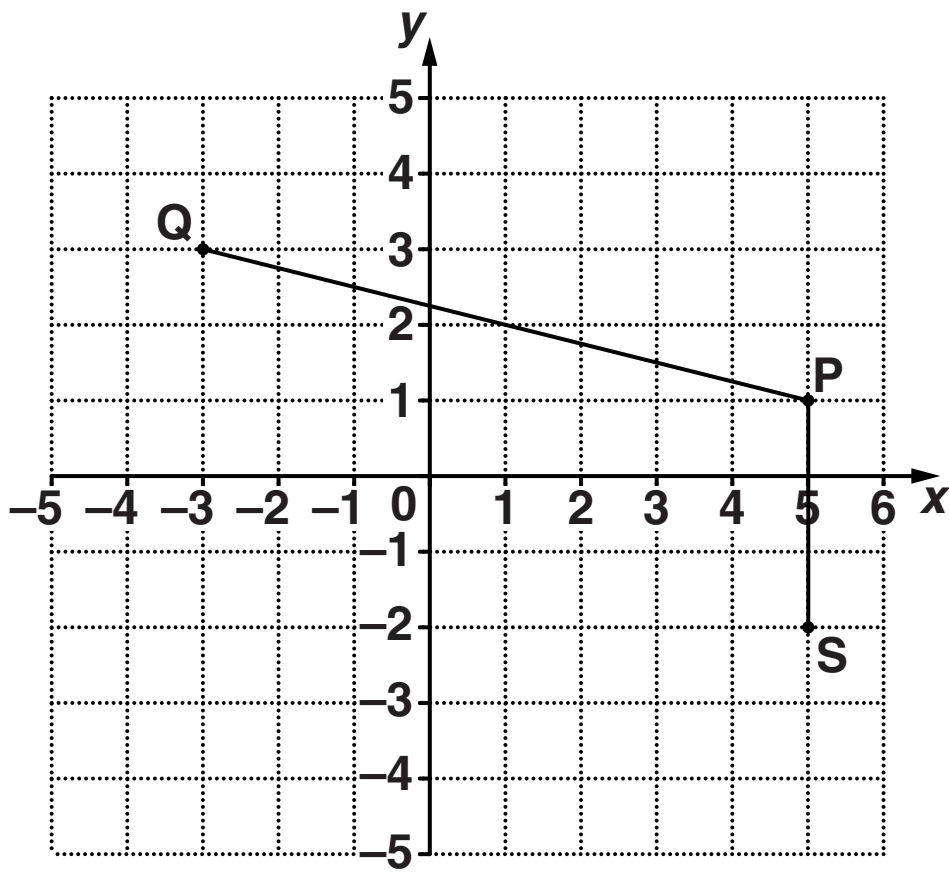

(a) Write down the coordinates of point P.

(a) ( \_\_\_\_\_ , \_\_\_\_\_ ) [1]

(b) Write down the coordinates of point Q.

(b) ( \_\_\_\_\_ , \_\_\_\_\_ ) [1]

**(c) Write down the coordinates of the midpoint of the line PQ.**

**(c) ( \_\_\_\_\_ , \_\_\_\_\_ ) [1]**

**Lizzie marks point R on the grid so that the shape PQRS is a parallelogram.**

**(d) Write down the coordinates of point R.**

**(d) ( \_\_\_\_\_ , \_\_\_\_\_ ) [1]**

- 8 Marcus wants to buy two rabbits.  
A pet shop has FOUR breeds of rabbit for sale:**

**Dwarf Lop (D)  
German Lop (G)  
Lionhead (L)  
Angora (A)**

- (a) Complete the table below, to show all the different pairs of breeds that Marcus could buy. You may not need all the spaces.**

<b>D D</b>	<b>D G</b>		

**[2]**



**(b) Marcus asks the pet shop owner for any two rabbits.**

**The pet shop owner makes a random selection from the completed table.**

**What is the probability that Marcus is NOT given a Lionhead rabbit?**

---

---

---

---

**(b) \_\_\_\_\_ [2]**

**9 Marnie is cooking meat sauce using these ingredients.**

<b>Meat sauce</b>	
<b>Minced beef</b>	<b>750g</b>
<b>Tomatoes</b>	<b>300g</b>
<b>Onions</b>	<b>2</b>

**At her local shop, minced beef is £6.80 per kilogram, onions are 33p each and tomatoes are 48p for 100 g.**

**Marnie pays for the ingredients with a £20 note.**

**How much change should she get?**

---

---

---

---

---

---

---

---

---

---

---

---

---

---

---

---

---

---

£ \_\_\_\_\_ [6]

10 (a) Work out the area of the rectangle.

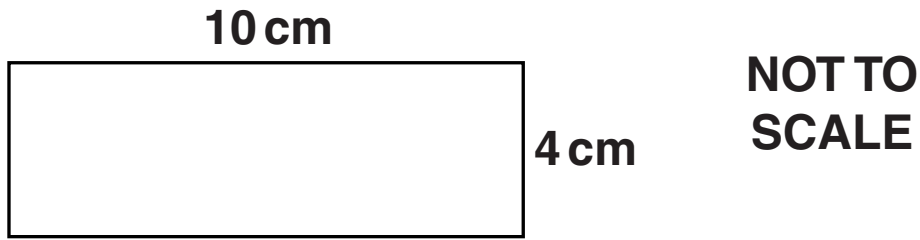

---

(a) \_\_\_\_\_ cm<sup>2</sup> [2]

(b) The rectangle in part (a) is enlarged.  
Its perimeter is now 280 cm.  
Huw says “The scale factor of the enlargement  
is 10.”

Is Huw correct?  
Show clearly how you decide.

---

---

---

---

\_\_\_\_\_ [2]

11 (a) Work out the value of  $10c + 20d$  when  $c = 12$  and  $d = 4$ .

---

---

(a) \_\_\_\_\_ [2]

(b) Simplify.

(i)  $m \times m \times m \times m \times m$

---

(b)(i) \_\_\_\_\_ [1]

(ii)  $8r + 2q + 3q - r$

---

---

(ii) \_\_\_\_\_ [2]

**12 This stem and leaf diagram shows the time, in seconds, for each student from class 10A to run 100m.**

<b>13</b>	<b>6</b>	<b>8</b>						
<b>14</b>	<b>0</b>	<b>0</b>	<b>3</b>	<b>7</b>				
<b>15</b>	<b>1</b>	<b>2</b>	<b>2</b>	<b>2</b>	<b>6</b>	<b>9</b>		
<b>16</b>	<b>0</b>	<b>1</b>	<b>4</b>	<b>5</b>	<b>7</b>	<b>7</b>	<b>8</b>	
<b>17</b>	<b>0</b>	<b>3</b>						
<b>18</b>	<b>7</b>							

**Key: 15 | 1 represents 15.1 seconds**

**(a) What was the longest time taken to run 100m?**

\_\_\_\_\_

**(a) \_\_\_\_\_ s [1]**

**(b) What is the range of the times?**

\_\_\_\_\_

**(b) \_\_\_\_\_ s [2]**

**(c) When students in class 10B recorded their times they had a range of 3.7 seconds.**

**Geoff says “10B has a smaller range of times than 10A so they were faster.”**

**Explain why Geoff is wrong.**

---

---

**[1]**

**BLANK PAGE**



13 Use the diagram below, to answer the questions which follow.

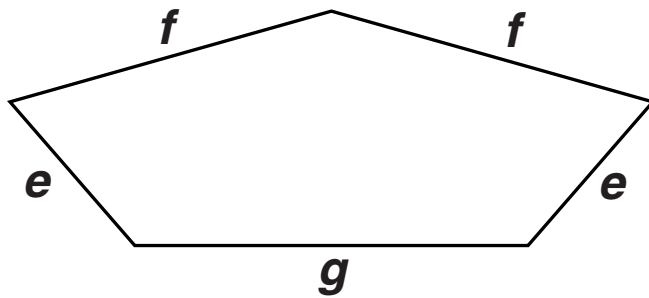

NOT TO  
SCALE

(a) What is the mathematical name for this shape?

(a) \_\_\_\_\_ [1]

(b) The perimeter of the shape is given by this formula.

$$P = 2e + 2f + g$$

Work out  $e$  when  $P = 33$  cm,  $f = 6.5$  cm and  $g = 8$  cm.

---

---

---

---

---

(b) \_\_\_\_\_ cm [3]

14 Use the grid below, to answer the questions which follow.

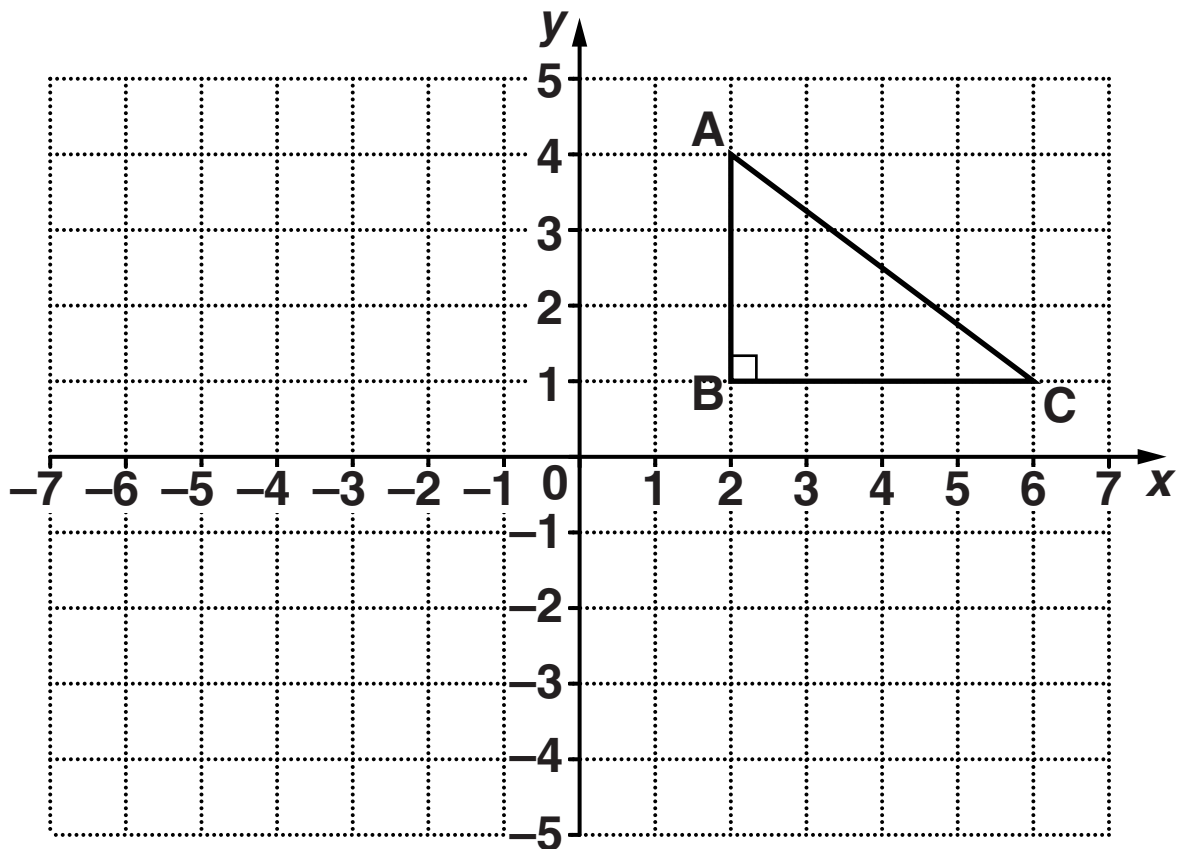

(a) Reflect triangle ABC in the  $y$ -axis. [2]

(b) Angle A is  $53^\circ$ .

Calculate angle C.

---

---

(b) \_\_\_\_\_  $^\circ$  [2]

**(c) Triangle ABC is enlarged by scale factor 5.**

**How big is angle A in the enlarged triangle?**

---

**(c)** \_\_\_\_\_ ° **[1]**

**15 (a) Calculate.**

**(i)  $0.5 \times 0.2$**

---

**(a)(i) \_\_\_\_\_ [1]**

**(ii)  $5^3$**

---

**(ii) \_\_\_\_\_ [1]**

**(b) (i) Change  $\frac{7}{8}$  into a percentage.**

---

---

---

---

**(b)(i) \_\_\_\_\_ % [2]**

**(ii) Use your answer to part (b)(i) to write  $\frac{7}{80}$  as a percentage.**

---

**(ii) \_\_\_\_\_ % [1]**

**16 Use ruler and compasses to construct a triangle with sides 9 cm, 7 cm and 6 cm.  
The 9 cm side has been drawn for you.**

**Show all your construction arcs.**



**[3]**

- 17 The table shows the ingredients needed to make vegetable soup for 4 people.

Vegetable soup (Serves 4 people)	
Vegetables	600 g
Stock	400 ml
Oil	3 tablespoons
Garlic	2 cloves

- (a) What weight of vegetables is needed to make vegetable soup for 3 people?

---

---

(a) \_\_\_\_\_ g [1]

- (b) How many tablespoons of oil are needed to make vegetable soup for 6 people?

---

---

(b) \_\_\_\_\_ [1]

**(c) Matt has only 1 litre of stock.  
He has plenty of the other ingredients.**

**What is the maximum number of people he can  
make vegetable soup for?**

---

---

**(c) \_\_\_\_\_ [2]**

- 18 In the diagram,  $ABC$  is parallel to  $DEF$  and  $BEG$  is parallel to  $ADH$ .  
 Angle  $EDH = 66^\circ$  and angle  $EAD = 34^\circ$ .

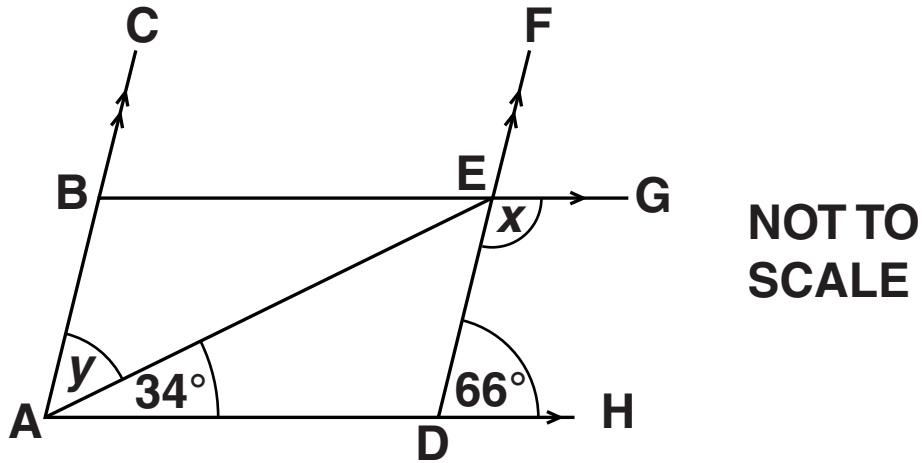

- (a) Work out the size of angle  $x$ .  
 Give a reason for your answer.

---



---

Angle  $x =$  \_\_\_\_\_  $^\circ$  because \_\_\_\_\_

---

[2]



**(b) Work out the size of angle  $y$ .  
Give a reason for your answer.**

---

---

**Angle  $y =$  \_\_\_\_\_ $^{\circ}$  because \_\_\_\_\_**

---

**[2]**

**BLANK PAGE**

**19 Solve.**

**(a)  $2(3x + 7) = 26$**

---

---

---

---

**(a)** \_\_\_\_\_ **[3]**

**(b)  $5x - 7 = 3x + 2$**

---

---

---

---

**(b)** \_\_\_\_\_ **[3]**

20 The table shows the lengths and weights of nine guinea pigs.

Length (cm)	15.2	15.5	15.8	15.8	16.0	17.0	17.5	17.8	18.0
Weight (g)	62	63	64	62	62	65	70	66	67

- (a) Complete the scatter diagram.  
The first five points have already been plotted.

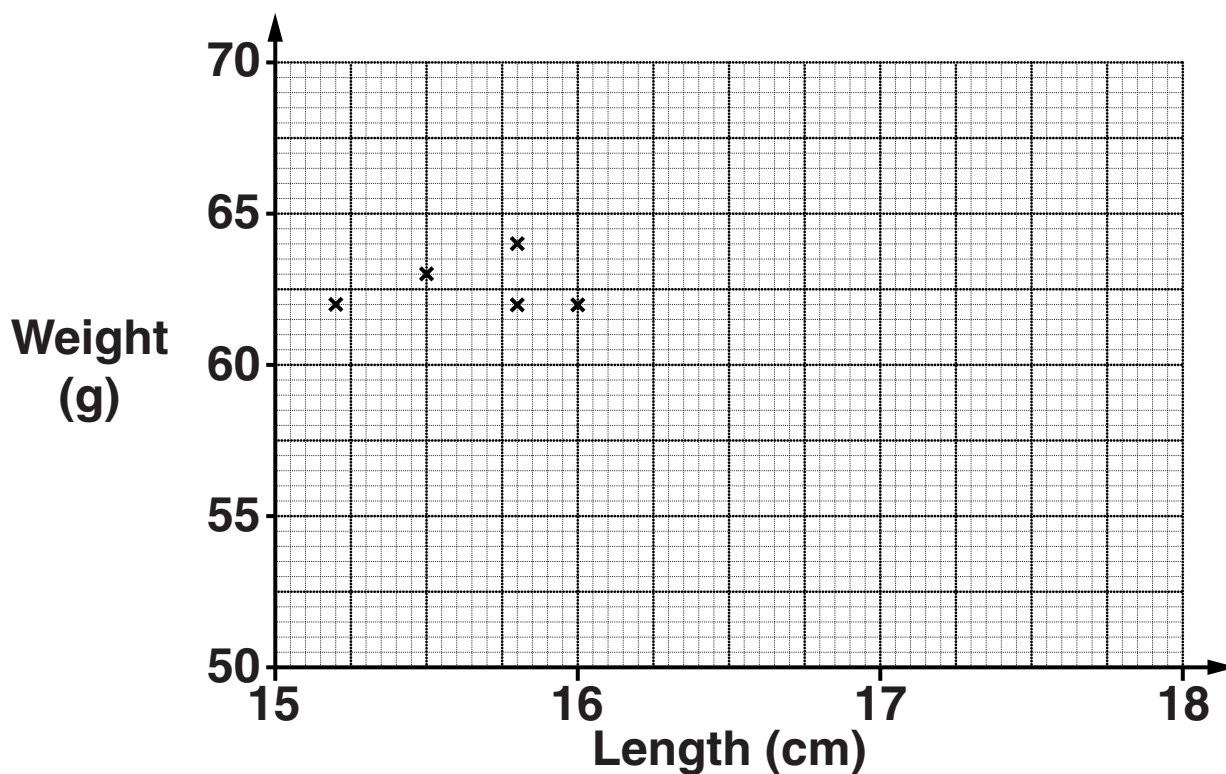

[2]

- (b) Describe the correlation shown in the diagram.

(b) \_\_\_\_\_ [1]

- (c) Draw a line of best fit on your diagram. [1]

**(d) Another guinea pig is 16.5 cm long.**

**Use your line of best fit to estimate its weight.**

**(d) \_\_\_\_\_ g [1]**

**(e) Jill says ‘If I could extend the horizontal axis and the line of best fit I could estimate the weight of a guinea pig which is 22 cm long’.**

**Explain why it would not be sensible for Jill to do this.**

\_\_\_\_\_  
\_\_\_\_\_ [1]

**21 Work out.**

(a)  $\sqrt{10^3 - 4 \times 15^2}$

---

---

---

---

(a) \_\_\_\_\_ [3]

(b)  $\frac{3}{4} \div \frac{7}{8}$

**Give your answer as a fraction in its simplest form.**

---

---

---

---

(b) \_\_\_\_\_ [2]

**22** A triangular prism has dimensions as shown in the diagram.

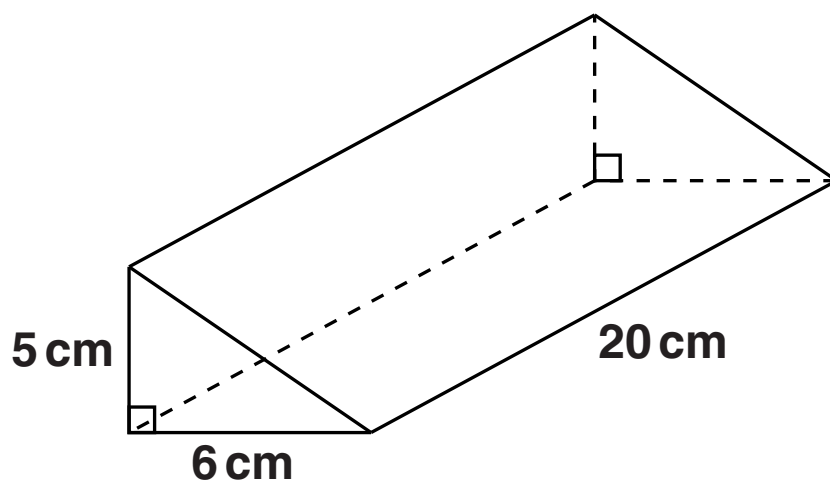

**Work out the volume of the prism.**

---

---

---

---

\_\_\_\_\_  $\text{cm}^3$  [3]

## **Copyright Information**

**OCR is committed to seeking permission to reproduce all third-party content that it uses in its assessment materials. OCR has attempted to identify and contact all copyright holders whose work is used in this paper. To avoid the issue of disclosure of answer-related information to candidates, all copyright acknowledgements are reproduced in the OCR Copyright Acknowledgements Booklet. This is produced for each series of examinations and is freely available to download from our public website ([www.ocr.org.uk](http://www.ocr.org.uk)) after the live examination series.**

**If OCR has unwittingly failed to correctly acknowledge or clear any third-party content in this assessment material, OCR will be happy to correct its mistake at the earliest possible opportunity.**

**For queries or further information please contact the Copyright Team, First Floor, 9 Hills Road, Cambridge CB2 1GE.**

**OCR is part of the Cambridge Assessment Group; Cambridge Assessment is the brand name of University of Cambridge Local Examinations Syndicate (UCLES), which is itself a department of the University of Cambridge.**