

Monday 16 January 2012 – Morning

GCSE MATHEMATICS SYLLABUS A

J512/02 Paper 2 (Foundation Tier)

Candidates answer on the Question Paper.

OCR supplied materials:
None

Other materials required:

- Electronic calculator
- Geometrical instruments
- Tracing paper (optional)

Duration: 2 hours



Candidate forename		Candidate surname	
--------------------	--	-------------------	--

Centre number							Candidate number				
---------------	--	--	--	--	--	--	------------------	--	--	--	--

INSTRUCTIONS TO CANDIDATES

- Write your name, centre number and candidate number in the boxes above. Please write clearly and in capital letters.
- Use black ink. HB pencil may be used for graphs and diagrams only.
- Answer **all** the questions.
- Read each question carefully. Make sure you know what you have to do before starting your answer.
- Show your working. Marks may be given for a correct method even if the answer is incorrect.
- Write your answer to each question in the space provided. Additional paper may be used if necessary but you must clearly show your candidate number, centre number and question number(s).
- Do **not** write in the bar codes.

INFORMATION FOR CANDIDATES

- The number of marks is given in brackets [] at the end of each question or part question.
- You are expected to use an electronic calculator for this paper.
- Use the π button on your calculator or take π to be 3.142 unless the question says otherwise.
- The total number of marks for this paper is **100**.
- This document consists of **24** pages. Any blank pages are indicated.

This paper has been pre modified for carrier language

Formulae Sheet: Foundation Tier

Area of trapezium = $\frac{1}{2} (a + b)h$



Volume of prism = (area of cross-section) \times length

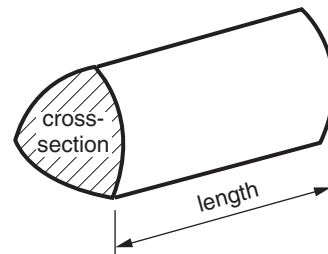

PLEASE DO NOT WRITE ON THIS PAGE

- 1 (a) What fraction of this diagram has been shaded?



(a) _____ [1]

- (b) Write $\frac{3}{4}$ as a decimal.

.....

(b) _____ [1]

- (c) Write these decimals in order of size, smallest first.

0.34 0.28 0.09 0.5

.....

(c) _____ *smallest* _____ [2]

- (d) All the tickets for a music concert cost the same amount.
 Three tickets cost £58.80.

How much does one ticket cost?

.....

(d) £ _____ [2]

2 (a) The Eiffel Tower is one thousand and sixty three feet tall.



Write one thousand and sixty three in figures.

(a) _____ [1]

(b) The CN Tower is 1815 feet tall.
The Dubai Tower is 2258 feet tall.

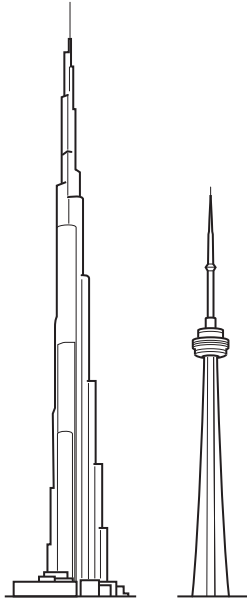

How much taller is the Dubai Tower than the CN Tower?

.....

.....

.....

(b) _____ feet [2]

- 3 (a) A mobile phone company charges 15p a minute for calls.
Text messages cost 8p each.

In December, Lily spoke to her friends on her mobile phone for a total of 53 minutes.
She also sent 32 text messages.

How much was Lily charged for calls and texts in December?

.....

.....

.....

.....

(a) £ _____ [3]

- (b) Tommy uses a different mobile phone company.
This company charges 20p a minute for the first five minutes of calls in each day
and then 5p for each minute after that.

On Thursday Tommy spoke for a total of 19 minutes on his mobile phone.

How much was Tommy charged for calls on Thursday?

.....

.....

.....

.....

(b) £ _____ [3]

4 This is a circle with centre O.

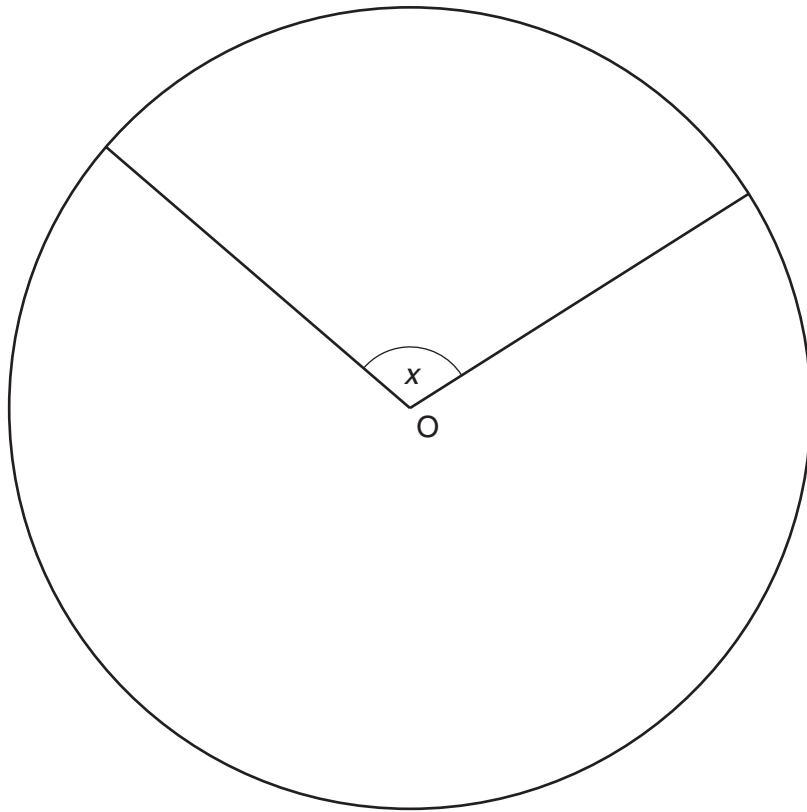

(a) Measure the radius of the circle.

(a) _____ cm [1]

(b) Measure angle x .

(b) _____ ° [1]

(c) Use one of these to describe angle x .

acute

right angle

reflex

obtuse

(c) _____ [1]

5 Claudia, Kalyan and Rhys are collecting one penny, two pence and five pence coins.

- (a) (i) Claudia has collected 72 one penny coins, 53 two pence coins and 35 five pence coins.

How much has Claudia collected altogether?

Give your answer in pounds and pence.

.....

(a)(i) £ _____ [2]

- (ii) Kalyan has collected £3.62 altogether.
 He has collected 53 one penny coins and 47 two pence coins.

How many five pence coins has he collected?

.....

(ii) _____ [2]

- (b) Rhys has 87 coins in a jar.

- (i) He has 25 one penny coins.
 He takes a coin from the jar without looking.

What is the probability that he takes a one penny coin from the jar?

(b)(i) _____ [1]

- (ii) The probability that Rhys takes a two pence coin from the jar is $\frac{1}{3}$.

How many two pence coins are there in the jar?

.....

(ii) _____ [2]

- (iii) How many five pence coins are in the jar?

.....

(iii) _____ [2]

- 6 Jack, a plumber, uses this rule to work out how much he charges for a job.



- (a) Jack does a job for Mr Chan that takes 3 hours.

How much does he charge?

.....

.....

.....

(a) £ _____ [2]

- (b) Jack charges Mrs Pryce £285.

How long did it take him to do this job?

.....

.....

.....

(b) _____ hours [2]

7 Use your calculator to work these out.

(a) 25% of 147.6

.....
.....

(a) _____ [2]

(b) $\frac{3}{7}$ of 50.4

.....
.....
.....

(b) _____ [2]

(c) 4% of 64.5

.....
.....
.....

(c) _____ [2]

- 8 (a) This regular hexagon and this square have the same perimeter. The length of one side of the hexagon is 4.6 cm.

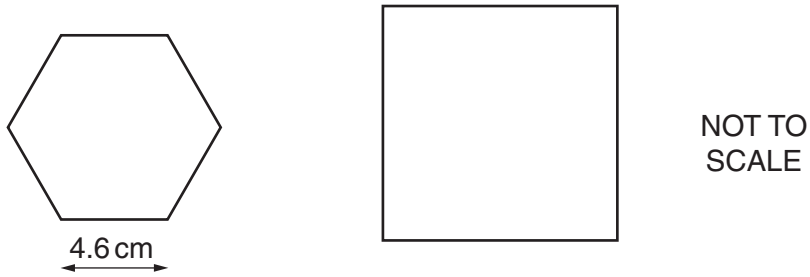

Work out the length of one side of the square.

.....

.....

.....

(a) _____ cm [3]

- (b) (i) Find the order of rotation symmetry of this shape.

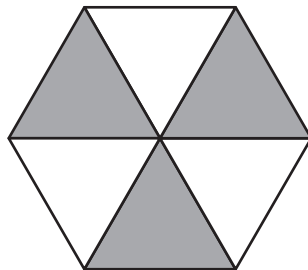

(b)(i) _____ [1]

- (ii) Shade 2 more small squares on this shape so that it has rotation symmetry of order 4.

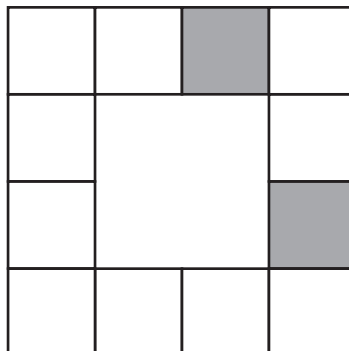

[1]

9 (a) These are the prices, in pence, of a 'Choco' chocolate bar in six supermarkets.

44 48 53 56 44 41

Work out

(i) the mode,

.....

(a)(i) _____ p [1]

(ii) the median,

.....

.....

.....

(ii) _____ p [2]

(iii) the range.

.....

(iii) _____ p [1]

(b) Five positive whole numbers have a mode of 6 and a median of 3.

What are the five numbers?

.....

.....

.....

.....

(b) _____ [2]

- 10 (a) Lisa and David were collecting data to find the favourite meal of students in Year 10. They gave this survey question to some of Year 10.

What is your favourite meal?

Fish and Chips
 Chicken Tikka Masala
 Spaghetti Bolognese
 Roast Beef
 Pizza

- (i) Explain why students may find the question difficult to answer.

[1]

- (ii) How could the question be improved?

[1]

- (b) Lisa and David collected their data in this tally chart.

Complete the chart by filling in the three empty boxes.

	Tally	Frequency
Fish and Chips		14
Chicken Tikka Masala		8
Spaghetti Bolognese		
Roast Beef		
Pizza		17

[2]

(c) Lisa and David present their results in this bar chart.

Complete the bar chart.

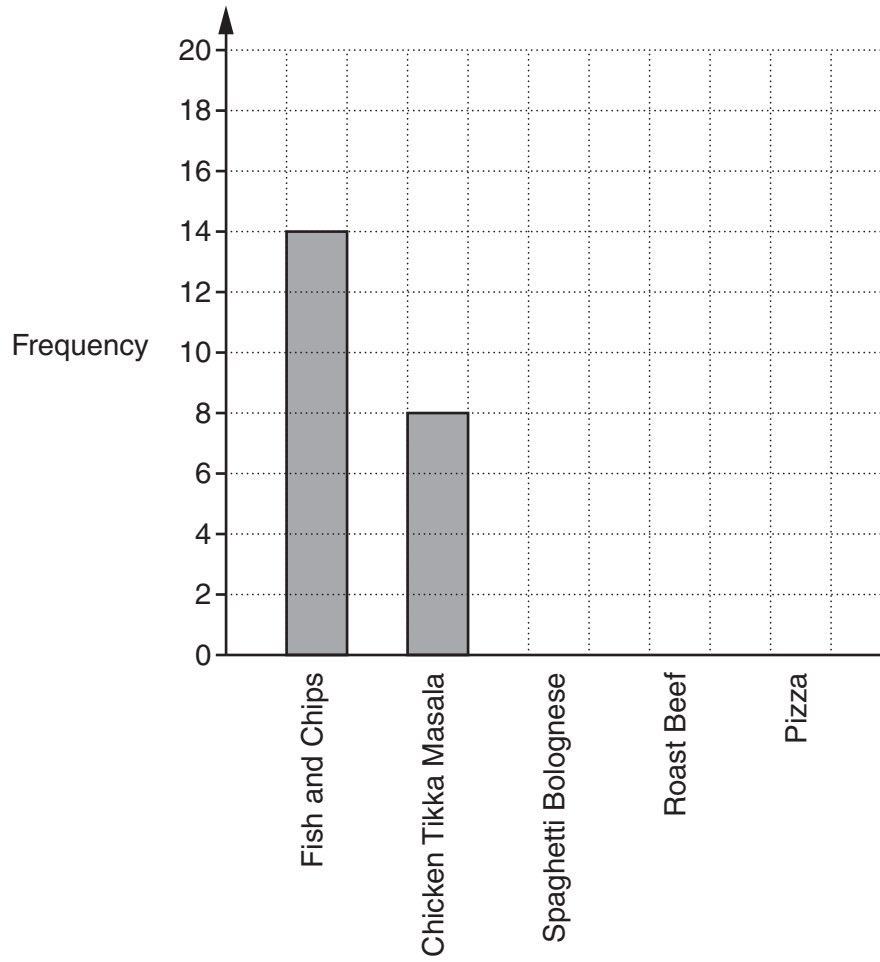

[2]

11 (a) Here is a list of numbers.

6 8 15 19 39 49 56

From this list write down

(i) a square number,

(a)(i) _____ [1]

(ii) a prime number,

(ii) _____ [1]

(iii) a cube number.

(iii) _____ [1]

(b) Some square numbers can be written as the sum of two prime numbers.
For example, $36 = 17 + 19$.

Find two prime numbers which have a sum of

(i) 16,

.....
.....
.....

(b)(i) _____ and _____ [1]

(ii) 25.

.....
.....
.....

(ii) _____ and _____ [1]

12 Tom has y songs in his music library.

(a) Lucy has fifteen more songs than Tom in her music library.

Write down an expression, in terms of y , for the number of songs Lucy has.

(a) _____ [1]

(b) Tesni has $y - 7$ songs in her music library.

Complete this sentence.

Tesni has 7 songs _____ than Tom. [1]

(c) Jason has $3y$ songs in his music library.

Complete this sentence.

Jason has _____ times as many songs as Tom. [1]

(d) Write down and simplify an expression, in terms of y , for the **total** number of songs that **Tom, Tesni and Jason** have altogether in their music libraries.

.....

(d) _____ [2]

13 Fill in the boxes for this pattern.

$$16^2 - 14^2 = 4 \times 15$$

$$14^2 - 12^2 = 4 \times 13$$

$$12^2 - 10^2 = 4 \times \boxed{}$$

$$10^2 - 8^2 = 4 \times 9$$

$$\boxed{} - \boxed{} = \boxed{} \times \boxed{}$$

[3]

14 (a) Complete the table for $y = 3x - 2$.

.....

.....

x	0	1	2	3	4
y		1			10

[2]

(b) Draw the graph of $y = 3x - 2$.

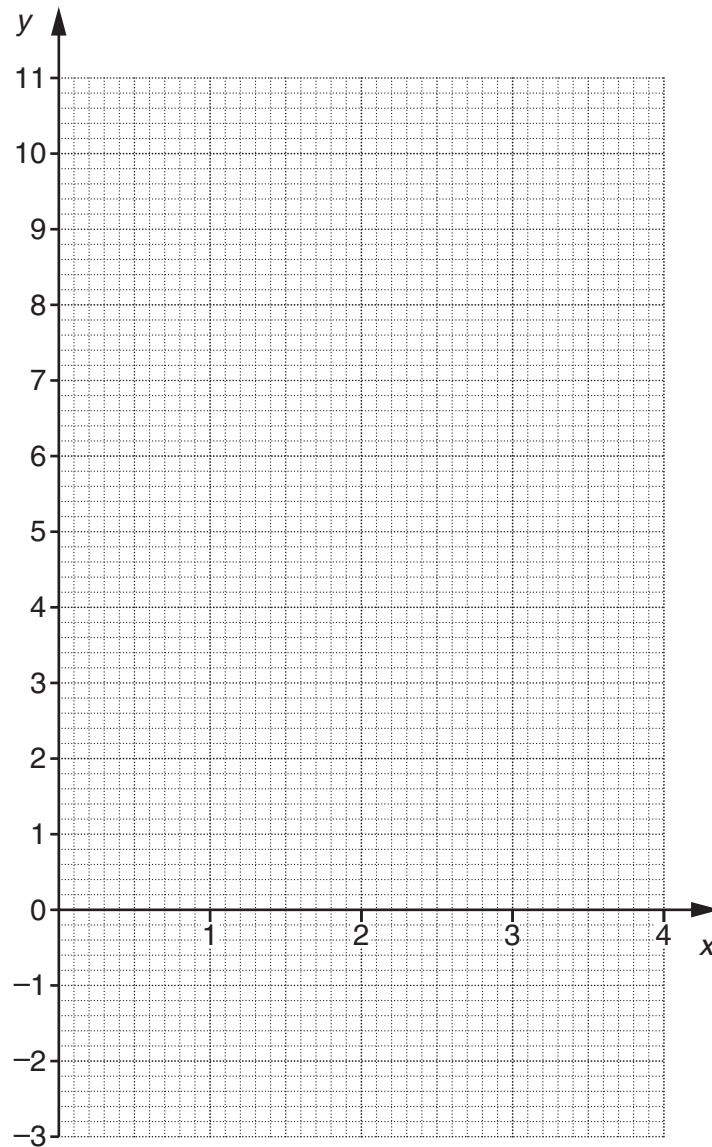

[2]

(c) Use your graph to find the value of x when $y = 5.8$.

(c) _____ [1]

15 A band of four musicians has a mean age of 34 years.

(a) What is the total of all the ages of the four musicians?

.....
.....

(a) _____ years [1]

(b) Stella, who is 24 years old, joins the band.

What is the mean age of the five members of the band?

.....
.....
.....
.....

(b) _____ years [2]

- 16 Dylan is putting cereal boxes into a packing case.
Each cereal box is a cuboid of width 5 cm, length 15 cm and height 25 cm.

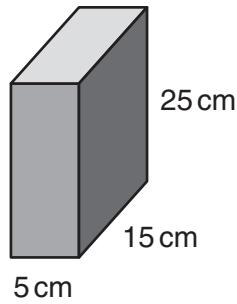

The packing case is a cuboid of width 50 cm, length 60 cm and height 50 cm.

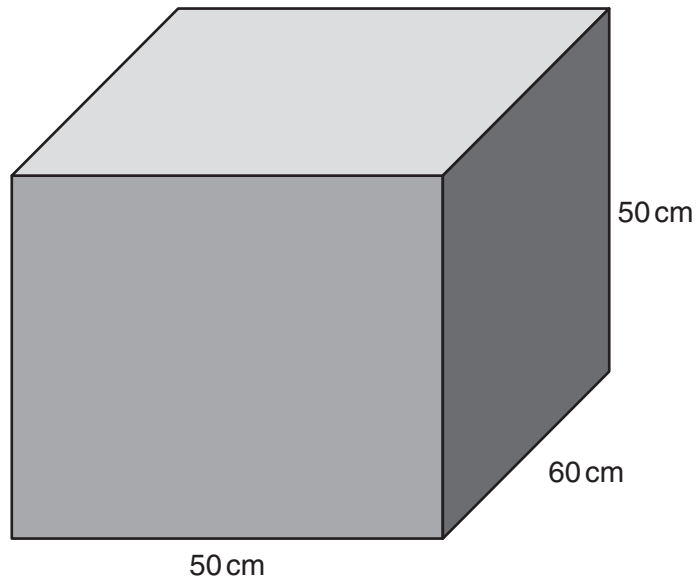

Dylan fills the packing case with cereal boxes so that there are no gaps.

How many cereal boxes does Dylan put into the packing case?

.....

.....

.....

.....

.....

.....

.....

.....

_____ [3]

17 Find the perimeter and area of this shape.

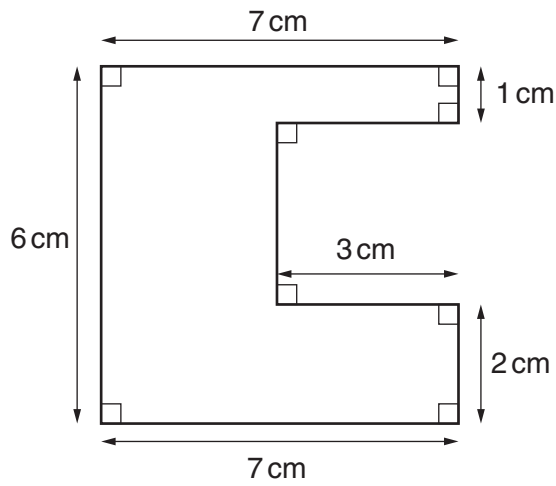

NOT TO SCALE

.....

.....

.....

.....

.....

.....

.....

.....

.....

Perimeter _____ cm

Area _____ cm² [4]

- 18 A lifeboat, B, is 9 km from a lighthouse, L, on a bearing of 320° .
A dinghy, D, is 5 km from the lighthouse, L, on a bearing of 075° .

- (a) Make a scale drawing to show the positions of the lifeboat and the dinghy.
Use a scale of 1 cm represents 1 km.



[4]

- (b) How far, and on what bearing, is the dinghy from the lifeboat?

.....
.....

(b) _____ km and _____ $^\circ$ [2]

19 Here is a sequence of diagrams.

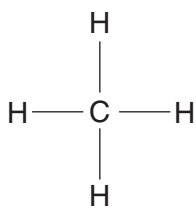

Diagram 1

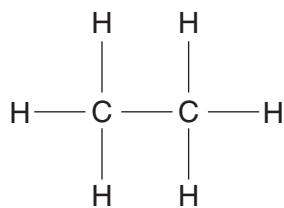

Diagram 2

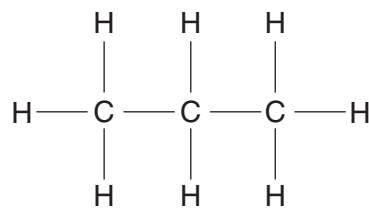

Diagram 3

(a) Draw Diagram 4.

[1]

(b) How many Cs and how many Hs will be in Diagram 7?

.....

.....

.....

(b) C _____

H _____ [2]

(c) Write down expressions in terms of n for the number of Cs and Hs in Diagram n .

.....

.....

.....

(c) C _____

H _____ [3]

- 20 Jonah drew shape **P** on a square grid. He then transformed shape **P** to shape **Q**.

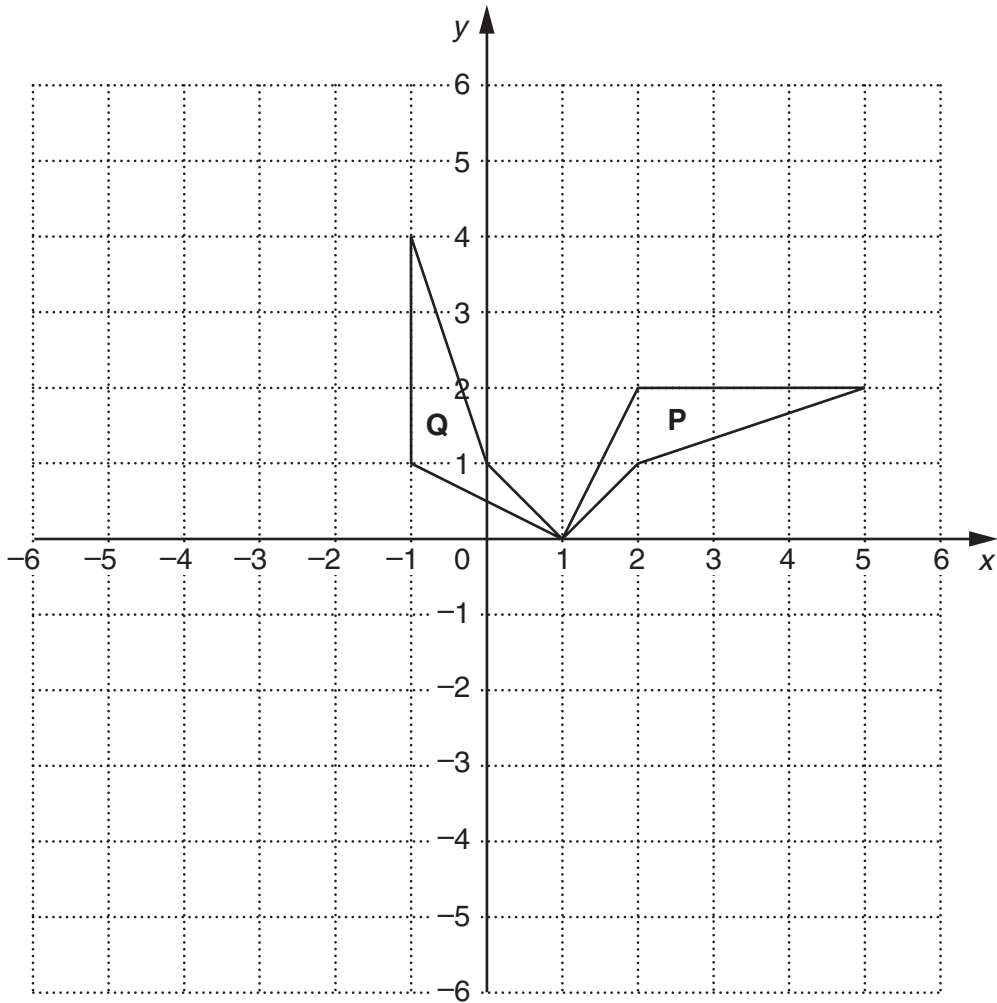

Describe fully the **single** transformation that maps shape **P** onto shape **Q**.

[3]

21

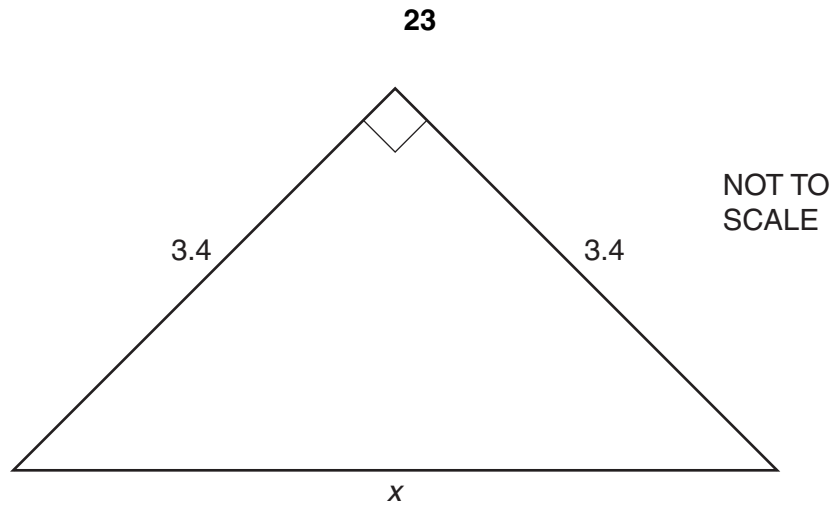

Calculate x .

.....

.....

.....

.....

.....

_____ [3]

PLEASE DO NOT WRITE ON THIS PAGE



Copyright Information

OCR is committed to seeking permission to reproduce all third-party content that it uses in its assessment materials. OCR has attempted to identify and contact all copyright holders whose work is used in this paper. To avoid the issue of disclosure of answer-related information to candidates, all copyright acknowledgements are reproduced in the OCR Copyright Acknowledgements Booklet. This is produced for each series of examinations and is freely available to download from our public website (www.ocr.org.uk) after the live examination series.

If OCR has unwittingly failed to correctly acknowledge or clear any third-party content in this assessment material, OCR will be happy to correct its mistake at the earliest possible opportunity.

For queries or further information please contact the Copyright Team, First Floor, 9 Hills Road, Cambridge CB2 1GE.

OCR is part of the Cambridge Assessment Group; Cambridge Assessment is the brand name of University of Cambridge Local Examinations Syndicate (UCLES), which is itself a department of the University of Cambridge.