

Candidate forename		Candidate surname	
-----------------------	--	----------------------	--

Centre number						Candidate number				
------------------	--	--	--	--	--	---------------------	--	--	--	--

**OXFORD CAMBRIDGE AND RSA EXAMINATIONS
GENERAL CERTIFICATE OF SECONDARY EDUCATION**

J512/04

MATHEMATICS SYLLABUS A

Paper 4 (Higher Tier)

FRIDAY 10 JUNE 2011: Morning

DURATION: 2 hours

SUITABLE FOR VISUALLY IMPAIRED CANDIDATES

Candidates answer on the question paper.

OCR SUPPLIED MATERIALS:

None

OTHER MATERIALS REQUIRED:

Electronic calculator

Geometrical instruments

Tracing paper (optional)

READ INSTRUCTIONS OVERLEAF

INSTRUCTIONS TO CANDIDATES

- **Write your name, centre number and candidate number in the boxes on the first page. Please write clearly and in capital letters.**
- **Use black ink. Pencil may be used for graphs and diagrams only.**
- **Read each question carefully. Make sure you know what you have to do before starting your answer.**
- **Show your working. Marks may be given for a correct method even if the answer is incorrect.**
- **Write your answer to each question in the space provided. Additional paper may be used if necessary but you must clearly show your candidate number, centre number and question number(s).**
- **Answer ALL the questions.**

INFORMATION FOR CANDIDATES

- **The number of marks is given in brackets [] at the end of each question or part question.**
- **You are expected to use an electronic calculator for this paper.**
- **Use the π button on your calculator or take π to be 3.142 unless the question says otherwise.**
- **The total number of marks for this paper is 100.**

Formulae Sheet: Higher Tier

$$\text{Area of trapezium} = \frac{1}{2}(a + b)h$$

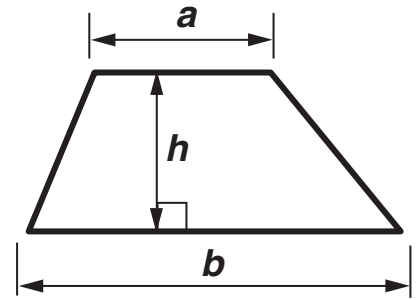

$$\text{Volume of prism} = (\text{area of cross-section}) \times \text{length}$$

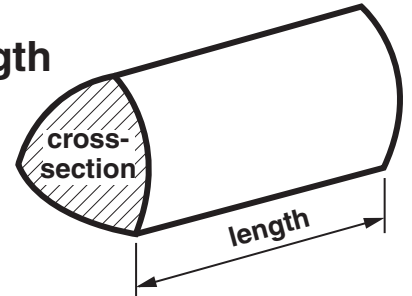

In any triangle ABC

$$\text{Sine rule} \quad \frac{a}{\sin A} = \frac{b}{\sin B} = \frac{c}{\sin C}$$

$$\text{Cosine rule} \quad a^2 = b^2 + c^2 - 2bc \cos A$$

$$\text{Area of triangle} = \frac{1}{2} ab \sin C$$

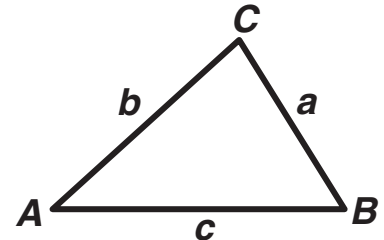

$$\text{Volume of sphere} = \frac{4}{3} \pi r^3$$

$$\text{Surface area of sphere} = 4\pi r^2$$

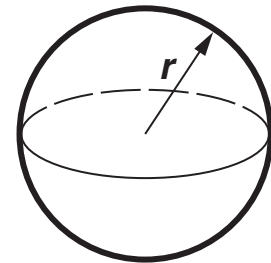

$$\text{Volume of cone} = \frac{1}{3} \pi r^2 h$$

$$\text{Curved surface area of cone} = \pi r l$$

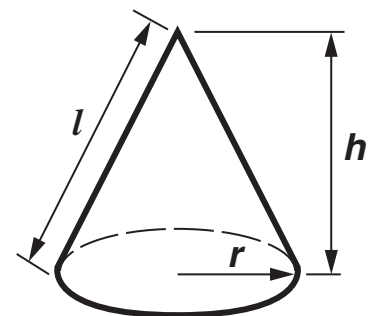

The Quadratic Equation

The solutions of $ax^2 + bx + c = 0$,
where $a \neq 0$, are given by

$$x = \frac{-b \pm \sqrt{(b^2 - 4ac)}}{2a}$$

- 1 Josh raised £650 for charity.
He divided the amount between two charities in the ratio 7 : 1.

How much did each charity receive?

£ _____

£ _____ [2]

2 (a) Calculate.

(i) $\frac{34.7}{6.97 + 7.68}$

Give your answer correct to 1 decimal place.

(a)(i) _____ [2]

(ii) $\sqrt{3.6^2 + 2.25}$

(ii) _____ [2]

(b) Jasmine wanted to work out this calculation.

$7200 \div 7.5$

She did not have a calculator.

Jasmine was told that $96 \times 0.75 = 72$.

Show how Jasmine could use this information to work out the calculation.

[1]

3 (a)

The front legs of a giraffe are always longer than the back legs.

Which one of these diagrams shows this information?

Diagram A

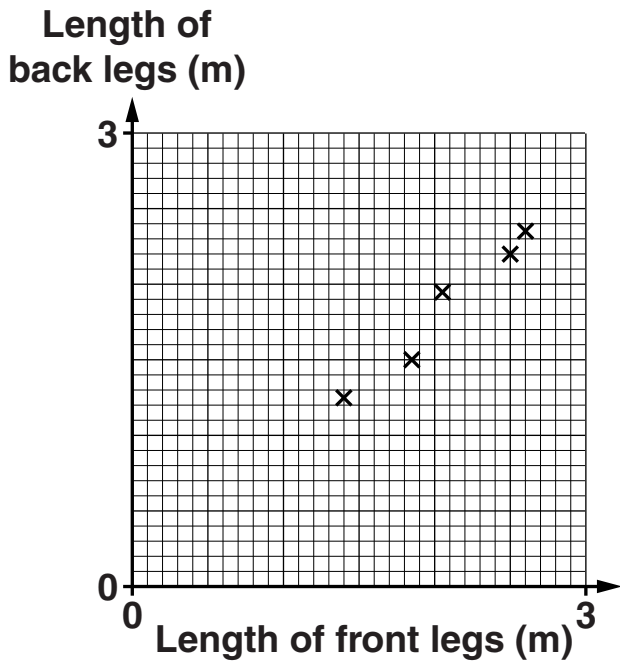

Diagram B

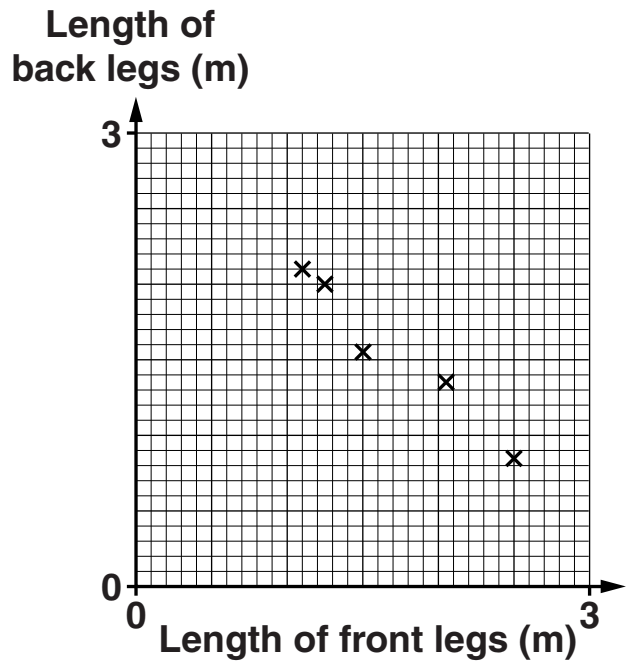

Diagram C

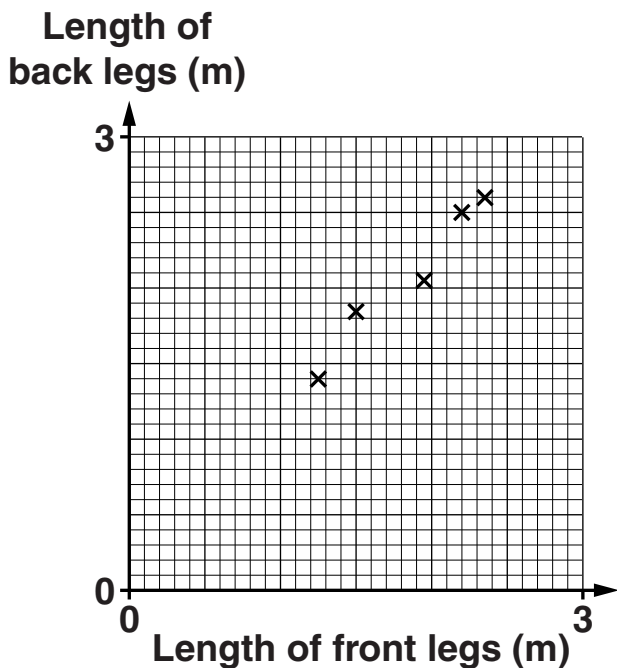
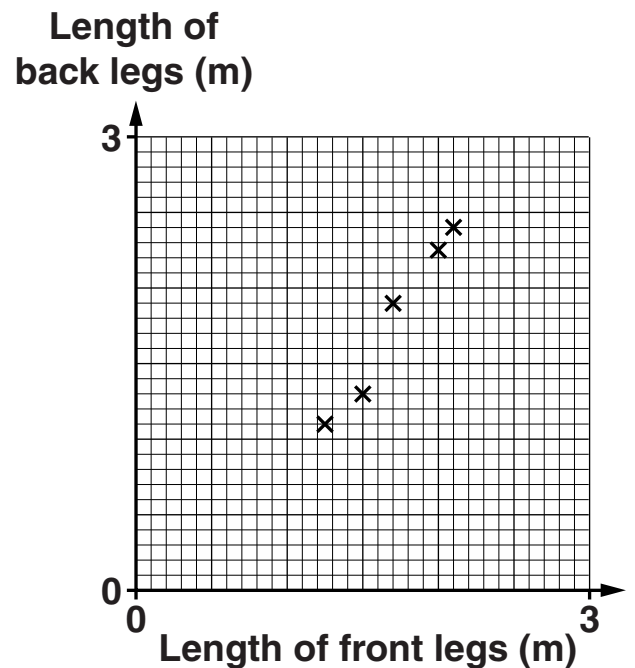

Diagram D



(a) Diagram _____ [1]

(b) The table summarises the times, in minutes, that giraffes in a herd slept during 24 hours.

Time (t minutes)	Frequency
$0 < t \leq 20$	1
$20 < t \leq 40$	4
$40 < t \leq 60$	10
$60 < t \leq 80$	12
$80 < t \leq 100$	3
$100 < t \leq 120$	2

(i) Write down the modal class interval for the time a giraffe in this herd slept.

(b)(i) _____ minutes [1]

(ii) Work out an estimate of the mean time that a giraffe in this herd slept in 24 hours.

(ii) _____ minutes [4]

(c) It is known that none of these giraffes slept for less than 15 minutes.

What effect does this fact have on

(i) the modal class,

_____ [1]

(ii) the mean?

_____ [1]

4 Here are details of the costs of making one pair of jeans.

- **1.75 m of denim at £4.20 per metre**
- **Labour £2**
- **Buttons etc 85p.**

The jeans are sold for £40.

Express the profit as a percentage of the SELLING price.

_____ % [4]

5 (a) Angie draws a quadrilateral with angles x° , x° , 135° and $3x^\circ$.

(i) Work out the value of x .

(a)(i) _____ [4]

(ii) Write down a mathematical name for the type of quadrilateral Angie has drawn.

(ii) _____ [1]

(b) A regular polygon has exterior angles of 20° .

Work out the number of sides of this polygon.

(b) _____ [2]

6 These are some of the ingredients needed for making beetroot brownies.

**250 g beetroot
200 g chocolate
3 eggs**

**Gareth picks a beetroot weighing 410 g.
He wants to use all the beetroot to make a batch of brownies.**

How much chocolate and how many eggs will he need?

Chocolate _____ g

Eggs _____ [3]

- 7 A drinking glass is a cylinder.
The interior dimensions of the glass are as shown.

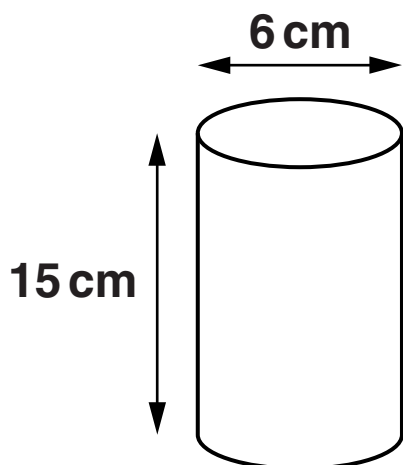

- (a) Work out the volume of liquid needed to fill the glass.

(a) _____ cm^3 [3]

- (b) Is it possible to pour the entire contents of a $\frac{1}{2}$ litre bottle of water into this glass?
Show how you decide.

- 8 This shape is made from 4 congruent rectangles.
The width of each rectangle is x cm.
The length of each rectangle is 6 times its width.
The total area of the shape is 150 cm^2 .

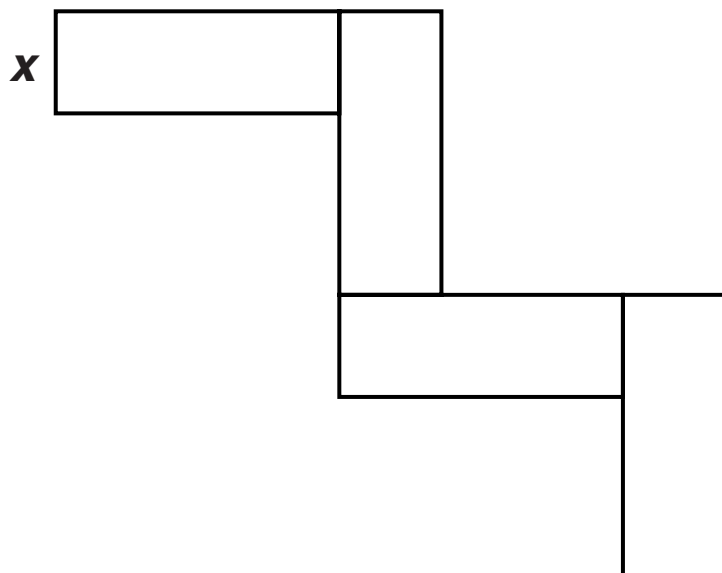

NOT TO SCALE

Write an equation in x .

Solve your equation and hence find the perimeter of the shape.

You must show all your working.

_____ cm [5]

- 9 Write 144 as a product of prime factors.
Give your answer using indices.**

_____ **[3]**

BLANK PAGE

10 On the grid, the graph of $x + y = 7$ has been drawn.

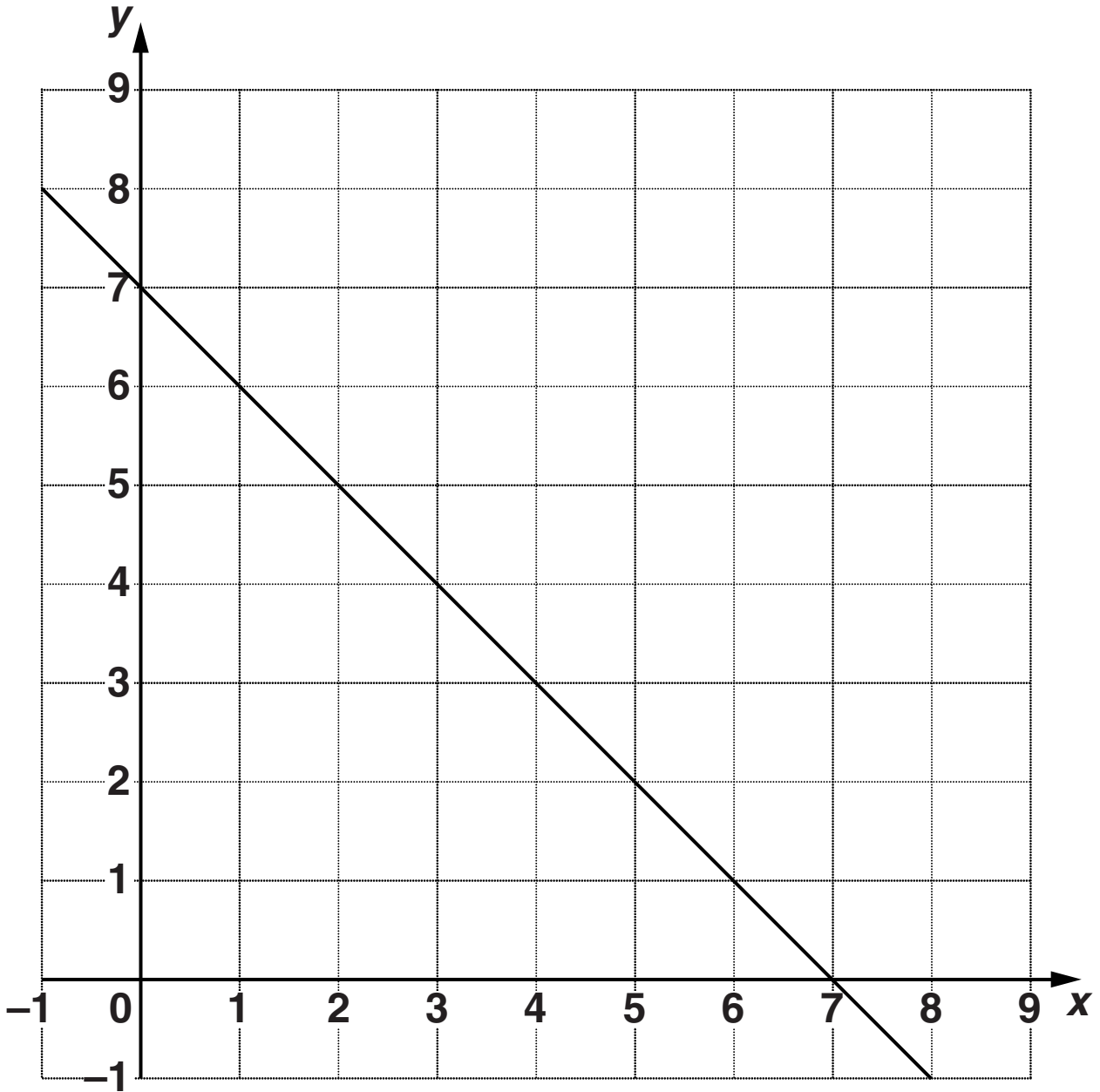

(a) On the same grid draw the graph of $y = 2x + 1$.

[3]

(b) Use the graphs to solve these simultaneous equations.

$$\begin{aligned}x + y &= 7 \\ y &= 2x + 1\end{aligned}$$

(b) $x =$ _____ $y =$ _____ [1]

11 (a) Factorise.

(i) $4x + 14$

(a)(i) _____ [1]

(ii) $x^2 - 5x$

(ii) _____ [1]

(iii) $x^2 - 16$

(iii) _____ [1]

(iv) $(x + y)^2 + 8(x + y)$

(iv) _____ [2]

(b) Rearrange $v = 6 + 5t$ to make t the subject of the formula.

(b) _____ [2]

(c) Multiply out and simplify.

$$2(3x + 7) + 3(5x - 4)$$

(c) _____ [2]

(d) Simplify.

$$\frac{2(x - 1)^2}{(x - 1)}$$

(d) _____ [1]

12 (a) The speed of light is approximately 300 000 000 m/s.

Write 300 000 000 in standard form.

(a) _____ [1]

(b) The wavelength of red light is approximately 0.000 000 65 m.

Write 0.000 000 65 in standard form.

(b) _____ [1]

BLANK PAGE

13 (a) O is the centre of the circle.

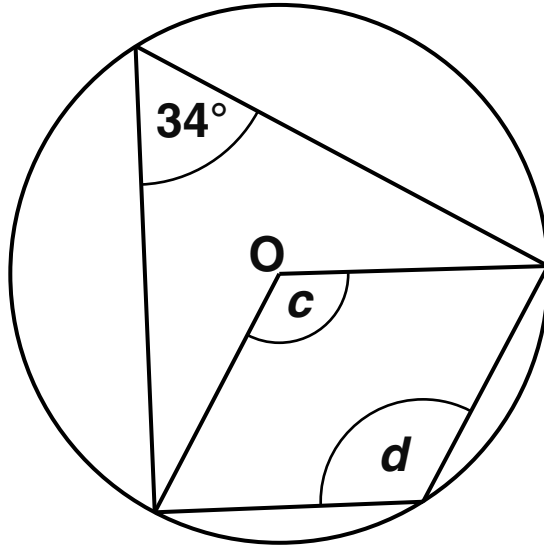

NOT TO SCALE

Find the sizes of angle c and angle d .
Write down a geometrical reason for each answer.

$c =$ _____ $^{\circ}$ because _____

$d =$ _____ $^{\circ}$ because _____

_____ [4]

(b) Tom draws a circle.

Jerry draws a circle with a diameter three times the diameter of Tom's circle.

Write down the ratio

area of Tom's circle : area of Jerry's circle.

(b) _____ : _____ [1]

(c) Barry draws a sector of a circle with dimensions as shown.

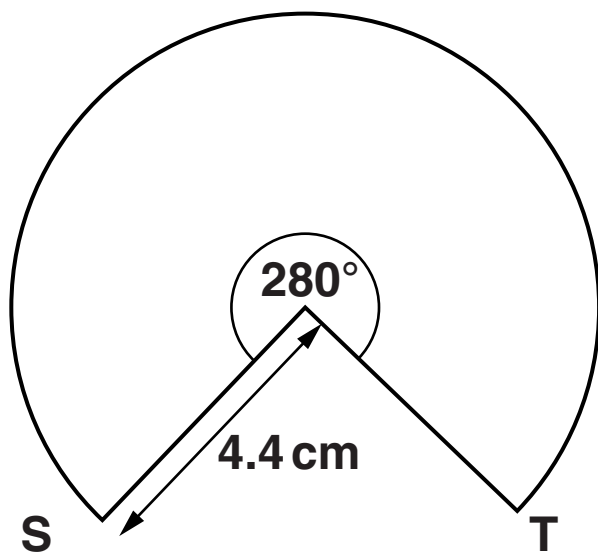

NOT TO SCALE

Calculate the length of the arc ST.

(c) _____ [3]

- 14 The sun's rays hit a tall building, casting a shadow along the ground.
The sun's rays make an angle of 52° with the ground.
The shadow of the building is 36.2 m long.

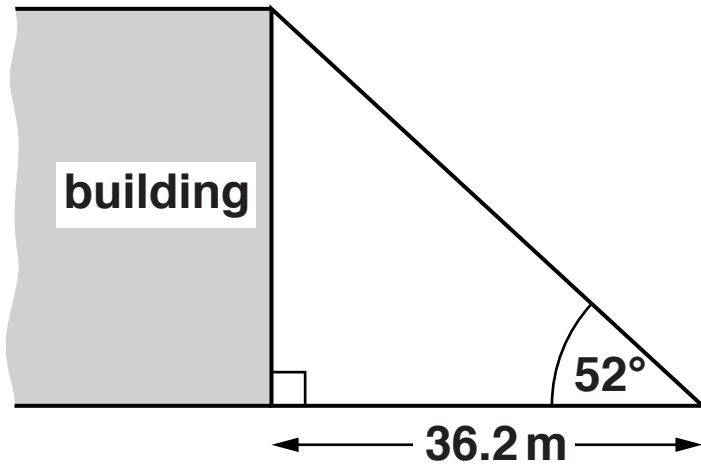

NOT TO SCALE

Work out the height of the building.
Give your answer to an appropriate degree of accuracy.

_____ m [4]

15 ABC is a triangle with dimensions as shown.

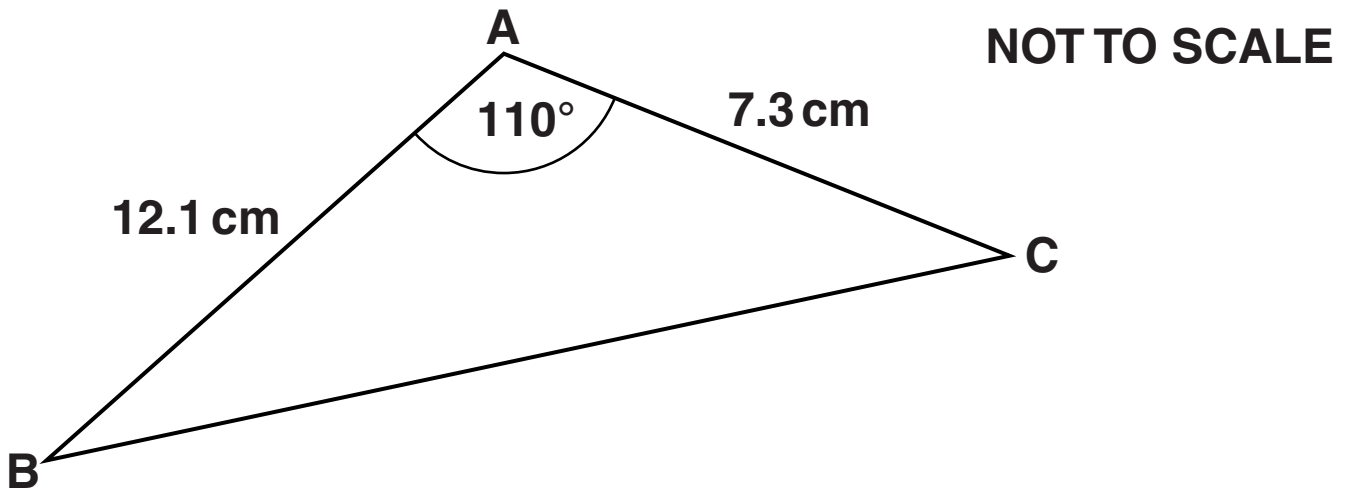

Work out the length BC.

_____ cm [3]

- 16 (a) Four students, Adil, Dev, Freddie and Shane, each kept a record of their scores at cricket one season.

The table summarises Adil's scores.

	Score
Lowest	10
Lower quartile	24
Median	40
Upper quartile	60
Highest	110

- (i) Draw a box plot to summarise Adil's scores.

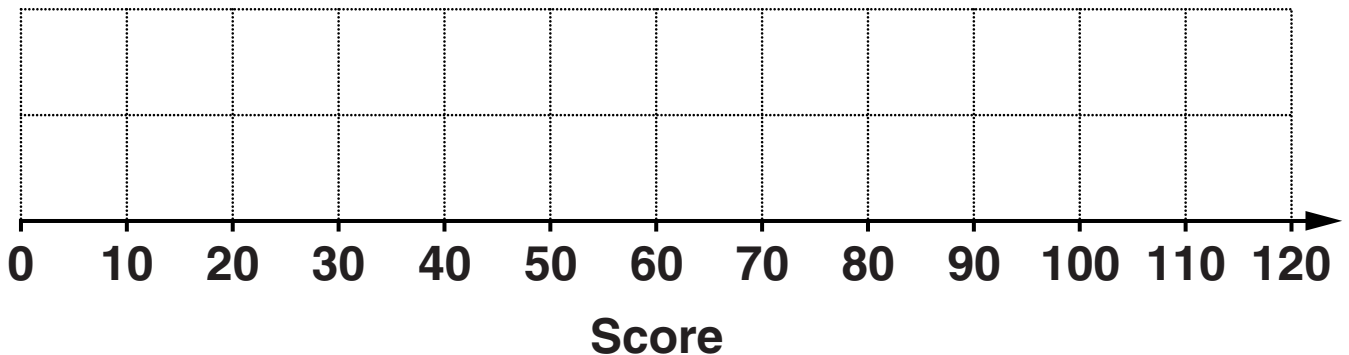

[2]

The box plot below summarises Dev's scores.

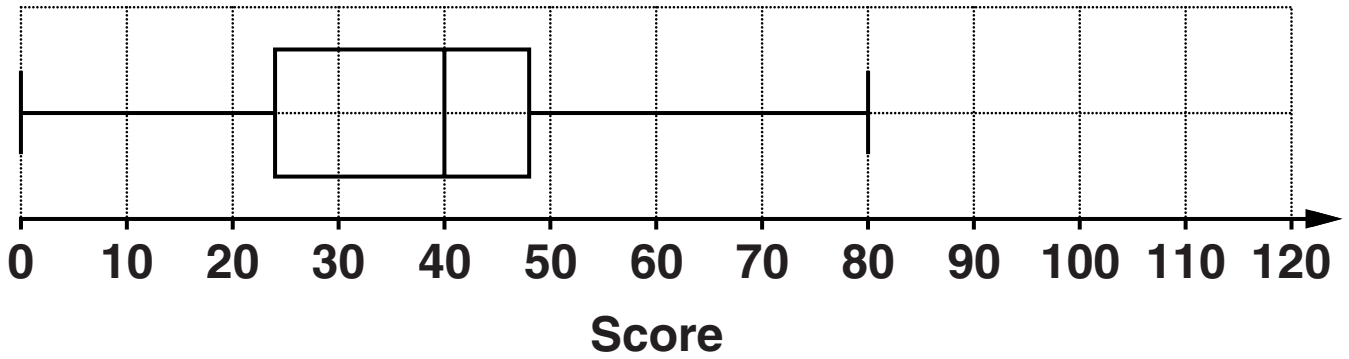

(ii) State one similarity and one difference between Adil's scores and Dev's scores.

Similarity _____

Difference _____

_____ [2]

(iii) Freddie and Shane summarised their scores in these frequency diagrams.

Freddie

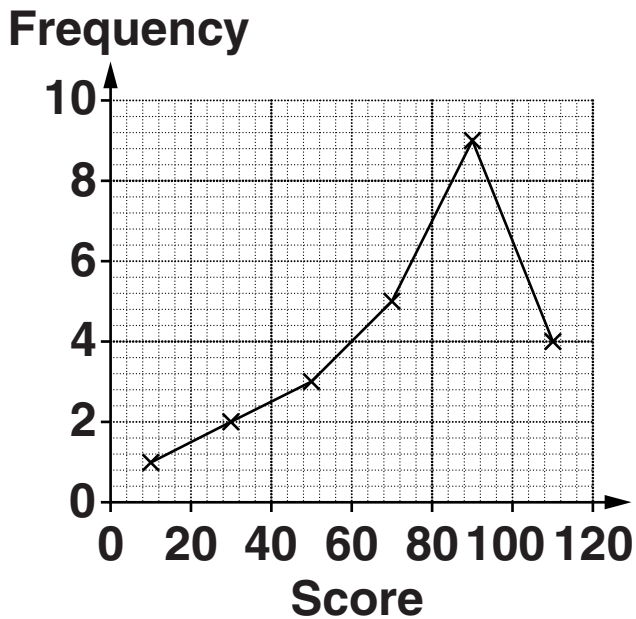

Shane

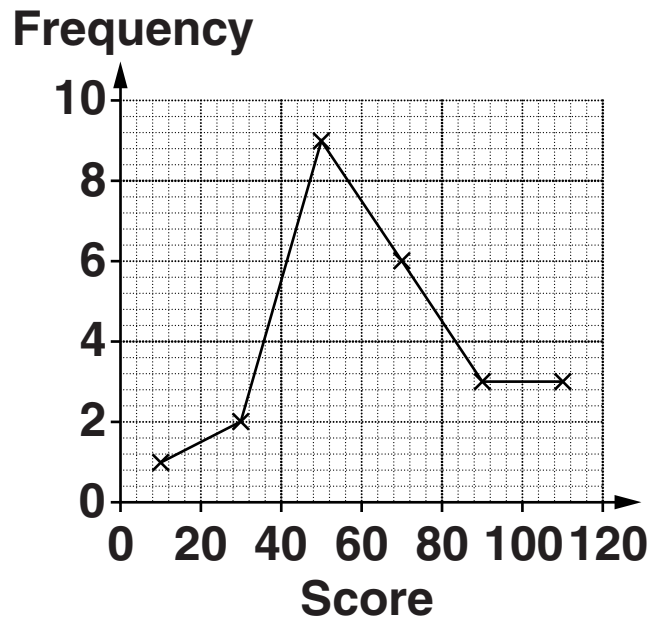

All four students have the same number of scores.

The school magazine contained the following report about one of the four students.

He batted brilliantly. He scored zero only once. He scored over 100 several times and his mean score was over 75.

Which student, Adil, Dev, Freddie or Shane, is the report describing?

Give reasons to support your choice of student, using the information in the report to explain fully why the report cannot be describing any of the other three students.

[4]

(b) The Head of PE wants to carry out a survey to find out how much sport students play during the summer holidays.

She wants to take a representative sample of 75 students stratified by gender.

There are 320 boys and 180 girls at the school.

Work out how many boys should be included in the sample.

(b) _____ [2]

17 (a) Complete this table for $y = 4^x$.

x	-1	-0.5	0	0.5	1	1.5	2
y	0.25	0.5		2	4		16

[2]

(b) Draw the graph of $y = 4^x$ for $-1 \leq x \leq 2$.

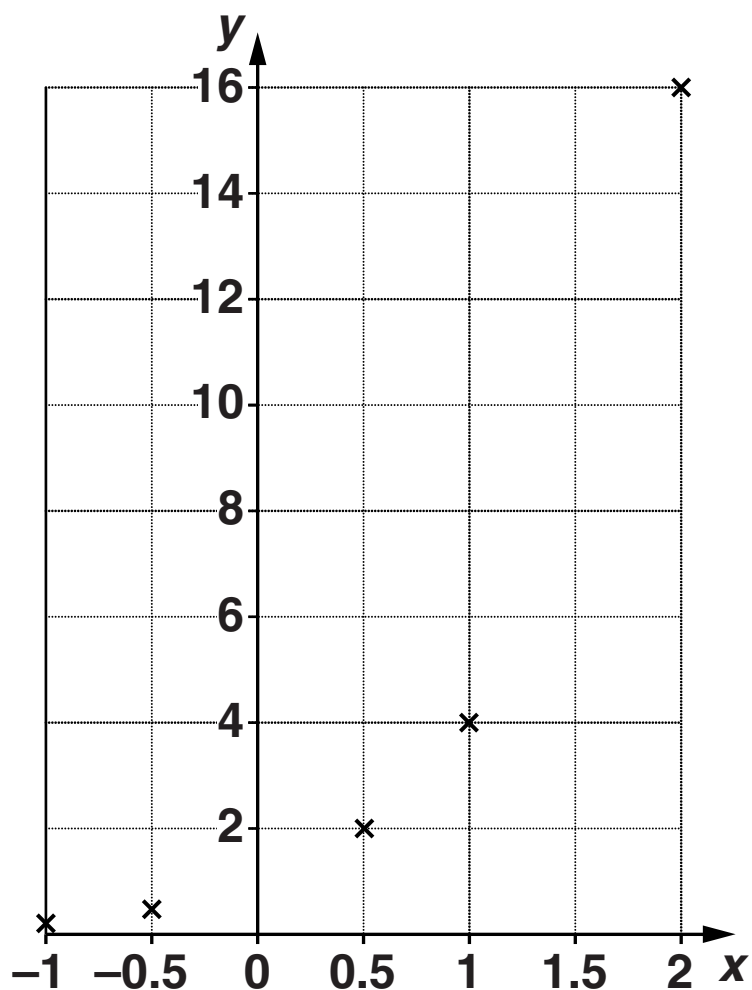

[2]

(c) Use the graph to solve the equation $4^x = 12$.

(c) _____ [1]

18 (a) Solve $2\sqrt{x} = 18$.

(a) _____ [2]

(b) Solve $\cos x = -0.5$ for $0^\circ < x < 360^\circ$.

(b) _____ [2]

19 The height, h , of an image on a whiteboard is directly proportional to the distance, d , of the whiteboard from the projector.

The image is 24 cm high when the projector is 120 cm from the whiteboard.

(a) Find an equation connecting h and d .

(a) _____ **[3]**

(b) Work out the height of the image on the whiteboard when the projector is moved 15 cm **FURTHER AWAY** from the whiteboard.

(b) _____ **[2]**

20 (a) Find a and b when

$$x^2 + 4x + 17 = (x + a)^2 + b.$$

(a) $a =$ _____ $b =$ _____ [3]

(b) Write down the minimum value of $x^2 + 4x + 17$.

(b) _____ [1]

BLANK PAGE

BLANK PAGE

Copyright Information

OCR is committed to seeking permission to reproduce all third-party content that it uses in its assessment materials. OCR has attempted to identify and contact all copyright holders whose work is used in this paper. To avoid the issue of disclosure of answer-related information to candidates, all copyright acknowledgements are reproduced in the OCR Copyright Acknowledgements Booklet. This is produced for each series of examinations and is freely available to download from our public website (www.ocr.org.uk) after the live examination series.

If OCR has unwittingly failed to correctly acknowledge or clear any third-party content in this assessment material, OCR will be happy to correct its mistake at the earliest possible opportunity.

For queries or further information please contact the Copyright Team, First Floor, 9 Hills Road, Cambridge CB2 1GE.

OCR is part of the Cambridge Assessment Group; Cambridge Assessment is the brand name of University of Cambridge Local Examinations Syndicate (UCLES), which is itself a department of the University of Cambridge.