

Candidate forename		Candidate surname	
-------------------------------	--	------------------------------	--

Centre number						Candidate number				
--------------------------	--	--	--	--	--	-----------------------------	--	--	--	--

**OXFORD CAMBRIDGE AND RSA EXAMINATIONS
GENERAL CERTIFICATE OF SECONDARY EDUCATION**

J512/02

MATHEMATICS SYLLABUS A

Paper 2 (Foundation Tier)

FRIDAY 14 JANUARY 2011: Morning

DURATION: 2 hours

SUITABLE FOR VISUALLY IMPAIRED CANDIDATES

Candidates answer on the question paper.

OCR SUPPLIED MATERIALS:

None

OTHER MATERIALS REQUIRED:

Electronic calculator

Geometrical instruments

Tracing paper (optional)

READ INSTRUCTIONS OVERLEAF

INSTRUCTIONS TO CANDIDATES

- **Write your name, centre number and candidate number in the boxes on the first page. Please write clearly and in capital letters.**
- **Use black ink. Pencil may be used for graphs and diagrams only.**
- **Read each question carefully. Make sure you know what you have to do before starting your answer.**
- **Show your working. Marks may be given for a correct method even if the answer is incorrect.**
- **Write your answer to each question in the space provided. Additional paper may be used if necessary but you must clearly show your candidate number, centre number and question number(s).**
- **Answer ALL the questions.**

INFORMATION FOR CANDIDATES

- **The number of marks is given in brackets [] at the end of each question or part question.**
- **You are expected to use an electronic calculator for this paper.**
- **Use the π button on your calculator or take π to be 3.142 unless the question says otherwise.**
- **The total number of marks for this paper is 100.**

FORMULAE SHEET: FOUNDATION TIER

Area of trapezium = $\frac{1}{2} (a + b)h$

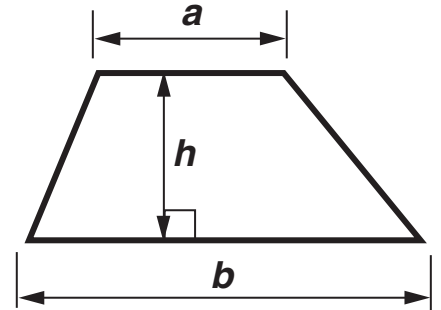

Volume of prism = (area of cross-section) × length

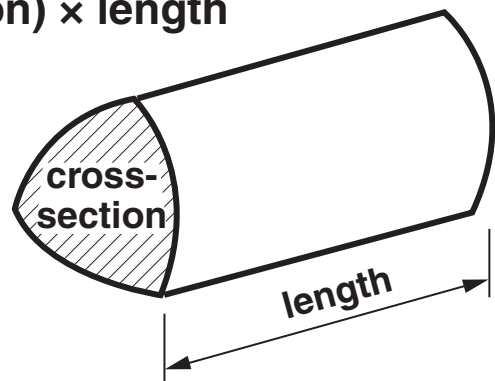

1 John works in a sandwich shop.

**(a) He has £10 to spend on bread.
A loaf of bread costs £1.15.**

How many loaves can John buy?

(a) _____ [2]

**(b) Cheese costs £9.70 for a kilogram.
John buys 500 grams of cheese.**

How much does John pay for the cheese?

(b) £ _____ [2]

- (c) Ham is sold in packs of 250 grams.
Each pack costs £2.55.
John buys 750 grams of ham.**

How much does John pay for the ham?

(c) £ _____ [2]

- (d) Cooked chicken costs £11.70 for a kilogram.
John buys 0.6 kilograms of cooked chicken.**

How much does John pay for the chicken?

(d) £ _____ [2]

2 The shapes in this question are drawn on grids of 1 cm squares.

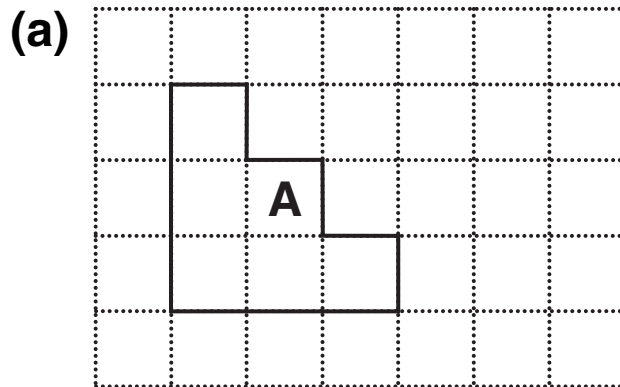

(i) Find the perimeter of shape A.

(a)(i) _____ cm [1]

(ii) Find the area of shape A.

(ii) _____ cm² [1]

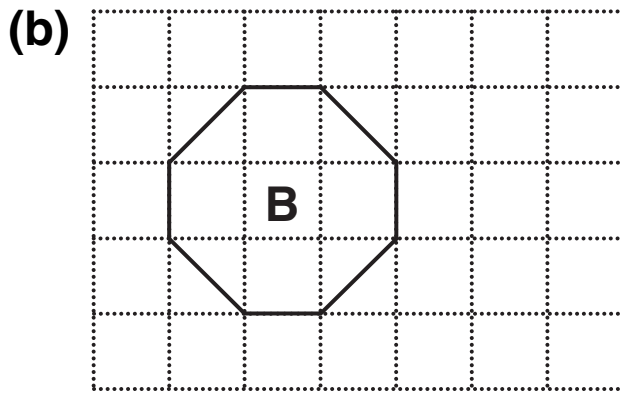

Find the area of shape B.

(b) _____ cm^2 [1]

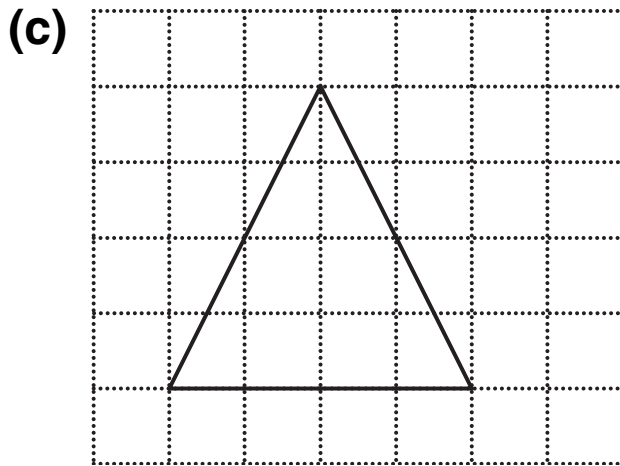

(i) What is the special mathematical name for this triangle?

(c)(i) _____ [1]

(ii) Find the area of the triangle.

(ii) _____ cm^2 [1]

- 3 Ria is playing a game to help learn the names of shapes.
She has these 6 cards.**

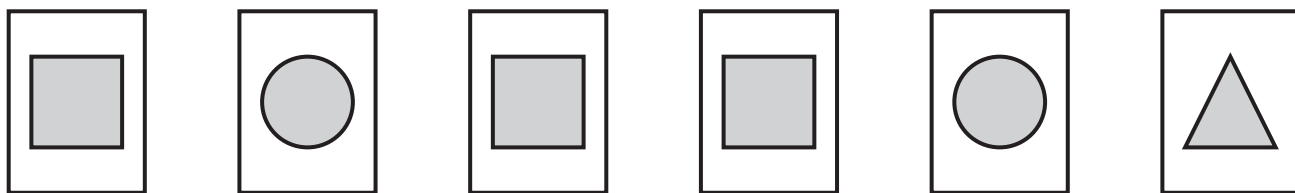

She picks one of these cards without looking.

Use one of these words to describe the probability of the events below.

certain likely impossible evens unlikely

(a) Ria picks a triangle.

(a) _____ [1]

(b) Ria picks a hexagon.

(b) _____ [1]

(c) Ria picks a square.

(c) _____ [1]

BLANK PAGE

4 The lines AB and XY are shown.

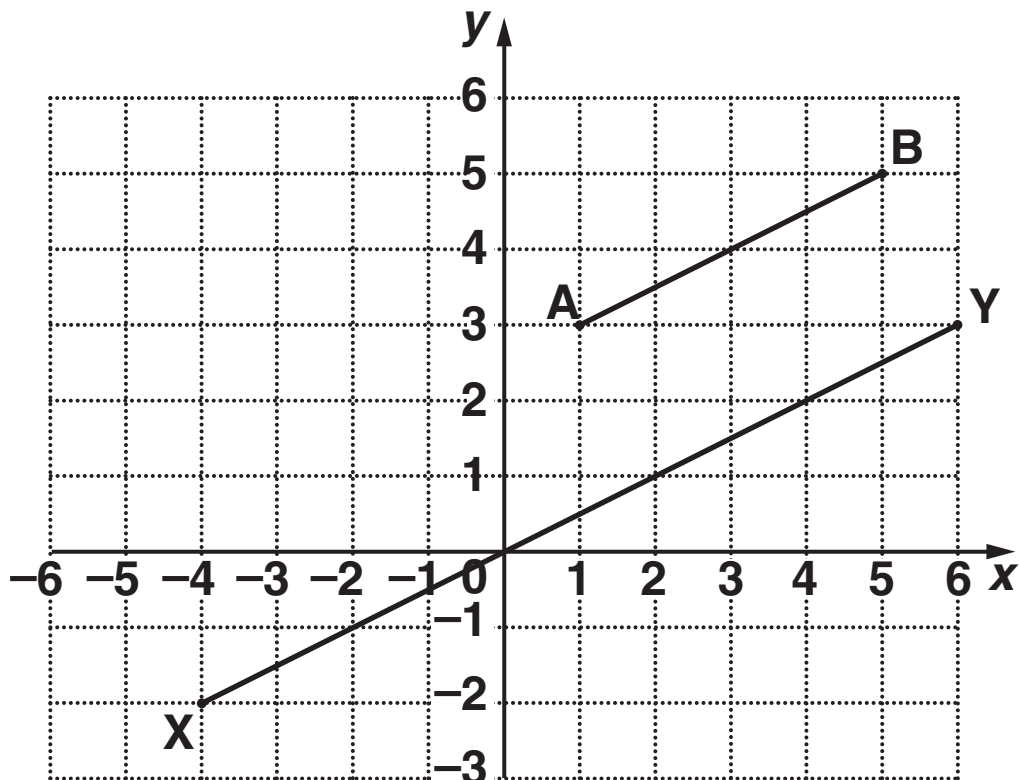

(a) Use one of these words to describe the lines AB and XY.

- vertical equal congruent parallel

(a) _____ [1]

(b) (i) Write down the coordinates of the point A.

(b)(i) (_____ , _____) [1]

(ii) Write down the coordinates of the point X.

(ii) (_____ , _____) [1]

(c) (i) Write down the coordinates of the midpoint of the line AB.

(c)(i) (_____ , _____) [1]

(ii) Mark on the grid the midpoint of the line XY and write down its coordinates.

(ii) (_____ , _____) [2]

(d) On the grid, draw a line that is perpendicular to the line AB. [1]

5 This chart shows the number of boys and girls in each year group who attend guitar lessons.

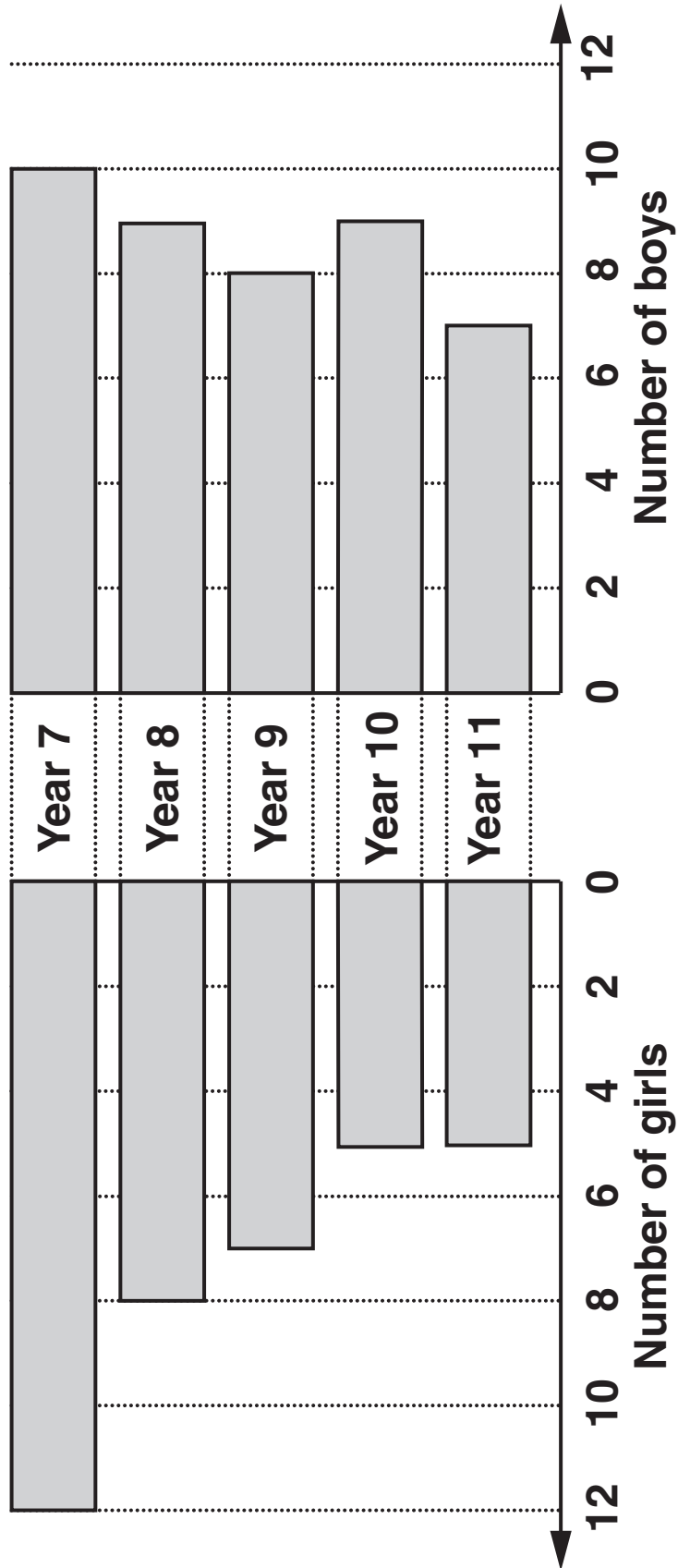

(a) How many Year 8 girls attend guitar lessons?

(a) _____ **[1]**

(b) How many Year 10 boys attend guitar lessons?

(b) _____ **[1]**

(c) Use the chart to compare the number of girls who attend guitar lessons with the number of boys who attend guitar lessons.

[1]

- 6 (a) This diagram shows a cuboid of width 3 cm, length 4 cm and height 2 cm.

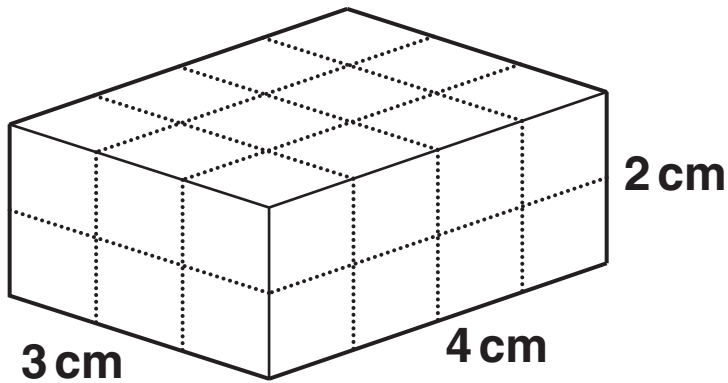

Find the volume of the cuboid.
Give the units of your answer.

(a) _____ [2]

- (b) A swimming pool is in the shape of a cuboid.
The swimming pool holds 480 m^3 of water.
The base of the swimming pool is a rectangle
with width 12 m and length 25 m.**

How deep is the water in the swimming pool?

(b) _____ m [2]

- 7 A cookery book gives the following rule for the length of time, in minutes, needed to roast a chicken.

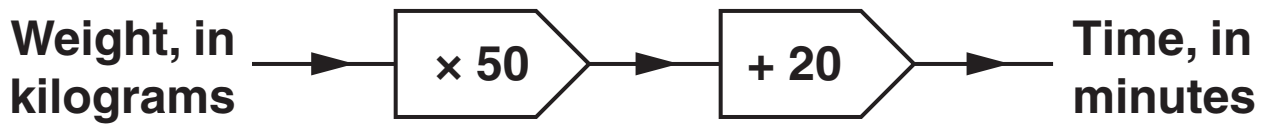

How long will it take to roast a chicken that weighs 2.3 kilograms?

_____ minutes [2]

- 8 Rose has 11 metres of material to make curtains and cushions.
She makes 4 curtains.
Each curtain needs 1.7 metres of material.
She uses the rest of the material to make 3 identical cushions.**

What length of material does she have for each cushion?

_____ m [4]

9 (a) These are the first five numbers of a sequence.

7 4 1 -2 -5

(i) What is the next number in the sequence?

(a)(i) _____ [1]

(ii) Explain how you found the next number in the sequence.

_____ [1]

(b) These are the first five numbers of another sequence.

1 2 4 7 11

(i) What is the next number in the sequence?

(b)(i) _____ [1]

(ii) Explain how you found the next number in the sequence.

_____ [1]

10 Ewan has n tracks on his MP4 Player.

(a) Jake has ten more tracks than Ewan on his MP4 Player.

Write down an expression in terms of n for the number of tracks Jake has.

(a) _____ [1]

(b) Luke has twice as many tracks as Ewan on his MP4 Player.

Write down an expression in terms of n for the number of tracks Luke has.

(b) _____ [1]

(c) Write down and simplify an expression in terms of n for the total number of tracks that the THREE boys have on their MP4 Players.

(c) _____ [2]

11 (a) These are the factors of 99.

1 3 9 11 33 99

Which of the factors of 99 are prime numbers?

(a) _____ [2]

(b) Write down all the factors of 20.

(b) _____ [2]

(c) A bank uses a code number on its computer. To crack the code you need to find the two prime numbers which multiply together to make the code number.

For example, for the code number 91, the two prime numbers that crack the code are 7 and 13 as $7 \times 13 = 91$.

What are the two prime numbers that crack the code for the following code numbers?

(i) 69

(c)(i) _____ , _____ [1]

(ii) 85

(ii) _____ , _____ [1]

12 This graph can be used to convert between pounds and kilograms.

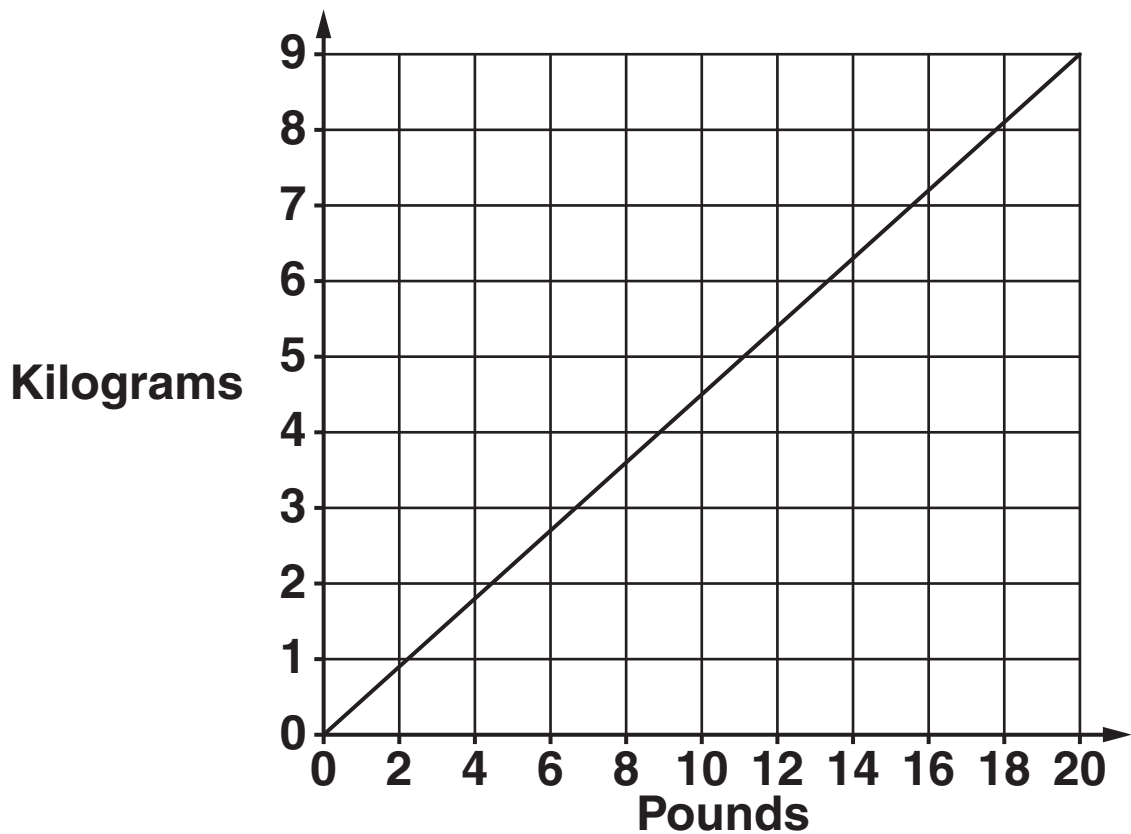

(a) Use the graph to convert

(i) 12 pounds into kilograms,

(a)(i) _____ kilograms [1]

(ii) 2 kilograms into pounds.

(ii) _____ pounds [1]

(b) (i) Use the graph to convert 32 pounds into kilograms.

(b)(i) _____ kilograms [1]

(ii) Explain how you worked out your answer to part (b)(i).

[1]

13 Marcie goes to the gym every day of the week. Each day, at the end of her session, Marcie records her pulse rate in beats per minute.

These are her pulse rates for the first week.

89 87 88 89 84 81 84

(a) (i) Find the mean of Marcie's pulse rates for the first week.

(a)(i) _____ [3]

(ii) Find the range of Marcie's pulse rates for the first week.

(ii) _____ [1]

(b) For the second week the mean of Marcie's pulse rates is 83 and the range is 5.

Use this information and the answers to part (a) to make two comparisons between Marcie's pulse rates for the first and second weeks.

1 _____

2 _____

_____ **[2]**

(b) (i) Use your table to find the probability of throwing a head and a 5.

(b)(i) _____ **[1]**

(ii) Use your table to find the probability of throwing a tail and an odd number.

(ii) _____ **[1]**

15 (a) Draw an enlargement of this pentagon with scale factor 2.

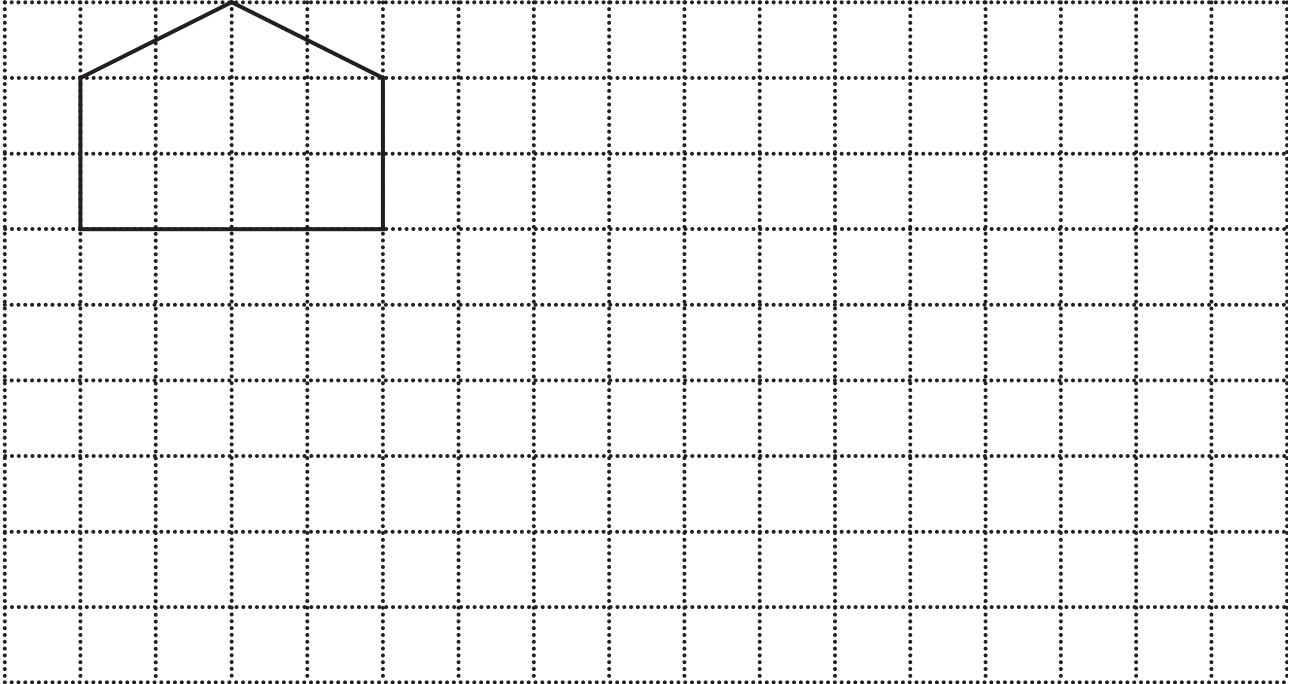

[2]

(b) Complete the pattern so that it has rotational symmetry of order 4.

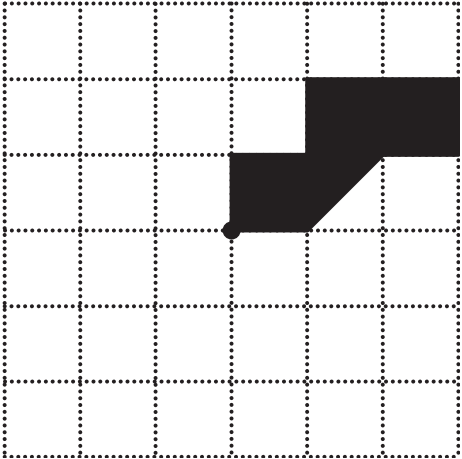

[3]

16 Calculate.

(a) $\frac{3.6 \times 4.7}{5.1 - 3.6}$

(a) _____ [2]

(b) $\frac{2}{3.6 + 1.7}$

Give your answer correct to 2 decimal places.

(b) _____ [2]

17 Sarfraz scored 13 out of 20 in his English exam, 63% in his Maths exam and 23 out of 35 in his Science exam.

**By converting his results in English and Science into percentages, put his exam results in order, lowest percentage first.
You must show your working.**

lowest

[4]

BLANK PAGE

18 Josh collected these data showing the midday temperature in degrees Fahrenheit, °F, for 15 places around the world on one day in December.

Place	Temperature °F
Athens	46
Bangkok	84
Calcutta	73
Dallas	57
Frankfurt	34

Place	Temperature °F
Gibraltar	59
Hong Kong	70
Jerusalem	61
Luxembourg	34
Melbourne	77

Place	Temperature °F
Perth	79
Rhodes	54
Sydney	81
Tenerife	68
Wellington	63

(a) Draw an ordered stem and leaf diagram to show these 15 temperatures.

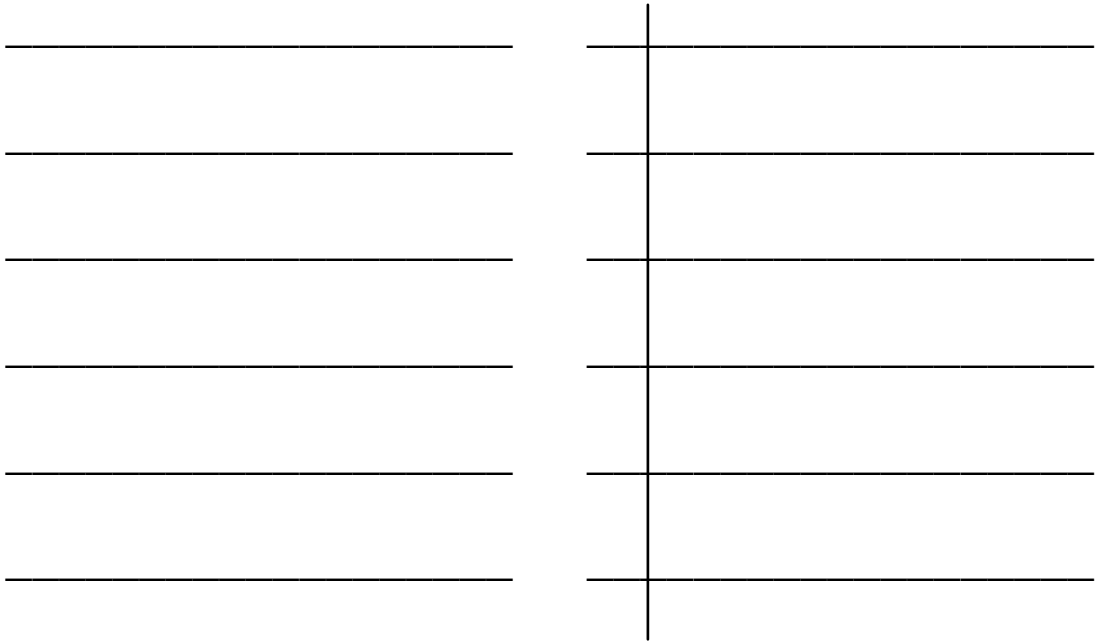

Key:

[3]

- (b) Josh chose 15 places each beginning with a different letter of the alphabet.
Suppose Josh had chosen Lisbon instead of Luxembourg to show in his table.
The temperature for Lisbon was 57°F.

Explain what effect this change would have on the mode and the median temperatures.

Effect on mode _____

Effect on median _____

[2]

19 Solve.

(a) $\frac{y}{5} = 20$

(a) _____ [1]

(b) $3p + 6 = p + 18$

(b) _____ [3]

20 In the year 2000 the average price of a house in the United Kingdom was £81 600.

(a) By 2005 the average price of a house had increased by 93%.

Find the average price of a house in 2005.

(a) £ _____ [3]

(b) In 1995 the average price of a house was £50 900.

Find the percentage increase in the average price of a house from 1995 to 2000.

(b) _____ % [3]

BLANK PAGE

21 Jenny is making a bird box for her technology project. This is the side elevation of her design.

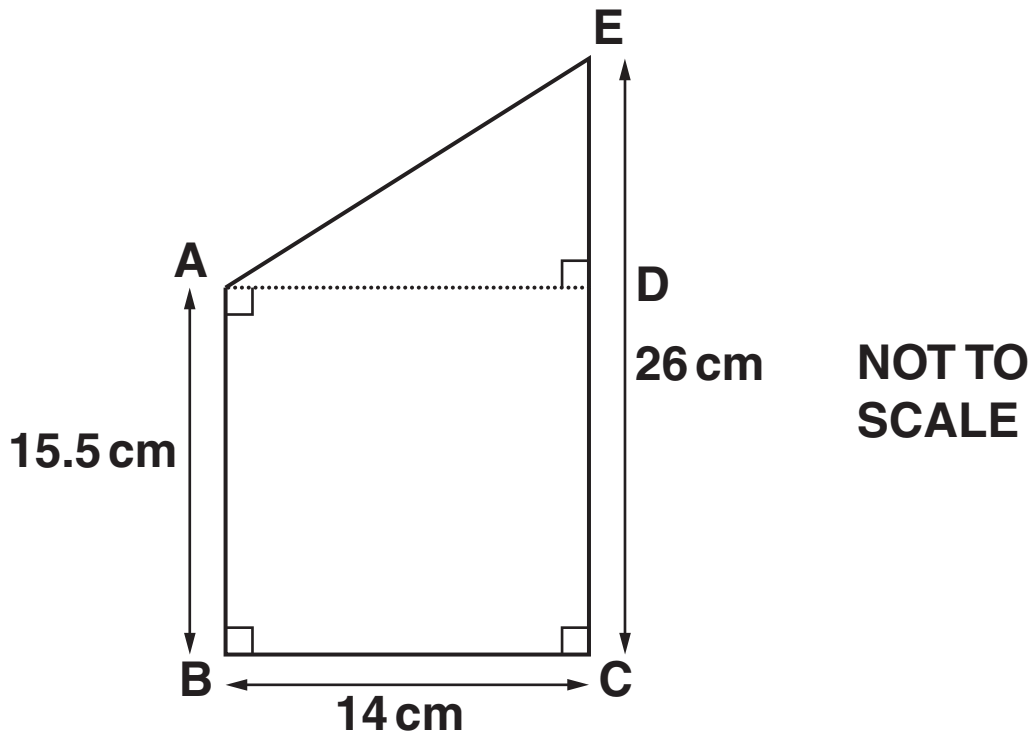

(a) Calculate the length DE.

(a) _____ cm [1]

(b) Calculate the length AE.

(b) _____ cm [3]

TURN OVER FOR QUESTION 22

22 Use trial and improvement to solve this equation.

$$x^3 - 2x = 7$$

**Give your answer to 1 decimal place.
Show all your trials and their outcomes.**

_____ [4]



Copyright Information

To avoid the issue of disclosure of answer-related information to candidates, all copyright acknowledgements are reproduced in the OCR Copyright Acknowledgements Booklet. This is produced for each series of examinations, is given to all schools that receive assessment material and is freely available to download from our public website (www.ocr.org.uk) after the live examination series.