



H

**GENERAL CERTIFICATE OF SECONDARY EDUCATION
MATHEMATICS SYLLABUS A**

J512/04

Paper 4 (Higher Tier)

Candidates answer on the question paper

OCR supplied materials:
None

Other materials required:

- Electronic calculator
- Geometrical instruments
- Tracing paper (optional)

**Friday 14 January 2011
Morning**

Duration: 2 hours



Candidate Forename		Candidate Surname	
--------------------	--	-------------------	--

Centre Number						Candidate Number				
---------------	--	--	--	--	--	------------------	--	--	--	--

INSTRUCTIONS TO CANDIDATES

- Write your name, centre number and candidate number in the boxes above. Please write clearly and in capital letters.
- Use black ink. Pencil may be used for graphs and diagrams only.
- Read each question carefully. Make sure you know what you have to do before starting your answer.
- Show your working. Marks may be given for a correct method even if the answer is incorrect.
- Write your answer to each question in the space provided. Additional paper may be used if necessary but you must clearly show your candidate number, centre number and question number(s).
- Answer **all** the questions.
- Do **not** write in the bar codes.

INFORMATION FOR CANDIDATES

- The number of marks is given in brackets [] at the end of each question or part question.
- You are expected to use an electronic calculator for this paper.
- Use the π button on your calculator or take π to be 3.142 unless the question says otherwise.
- The total number of marks for this paper is **100**.
- This document consists of **24** pages. Any blank pages are indicated.

Formulae Sheet: Higher Tier

Area of trapezium = $\frac{1}{2}(a + b)h$

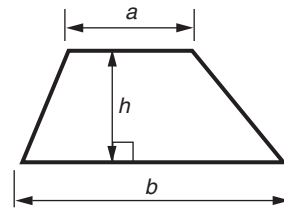

Volume of prism = (area of cross-section) \times length

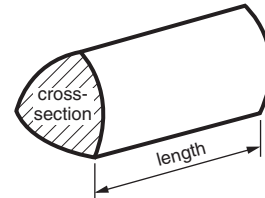

In any triangle ABC

Sine rule $\frac{a}{\sin A} = \frac{b}{\sin B} = \frac{c}{\sin C}$

Cosine rule $a^2 = b^2 + c^2 - 2bc \cos A$

Area of triangle = $\frac{1}{2}ab \sin C$

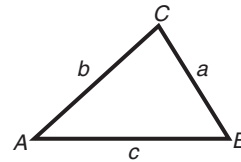

Volume of sphere = $\frac{4}{3}\pi r^3$

Surface area of sphere = $4\pi r^2$

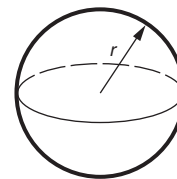

Volume of cone = $\frac{1}{3}\pi r^2 h$

Curved surface area of cone = $\pi r l$

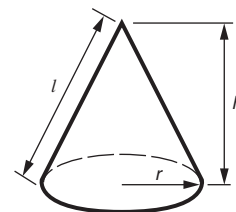

The Quadratic Equation

The solutions of $ax^2 + bx + c = 0$,
where $a \neq 0$, are given by

$$x = \frac{-b \pm \sqrt{b^2 - 4ac}}{2a}$$

PLEASE DO NOT WRITE ON THIS PAGE

1 Calculate.

(a) $\frac{3.6 \times 4.7}{5.1 - 3.6}$

.....
 (a) _____ [2]

(b) $\frac{2}{3.6 + 1.7}$

Give your answer correct to 2 decimal places.

.....
 (b) _____ [2]

2 Jonah bought two sizes of helium balloons for a party.
 He bought x small balloons at £2 each and 3 large balloons at £5 each.
 The total cost was £43.

(a) Write down an equation to show this information.

.....

 (a) _____ [2]

(b) Solve the equation to find the number of small balloons that Jonah bought.

.....

 (b) _____ [2]

- 3 A bag contains 1 yellow counter and 3 blue counters.

How many yellow counters must be added to the bag to double the probability of randomly choosing a yellow counter? Show how you found your answer.

[3]

4 Josh collected these data showing the midday temperature in degrees Fahrenheit, °F, for 15 places around the world on one day in December.

Place	Temperature °F	Place	Temperature °F	Place	Temperature °F
Athens	46	Gibraltar	59	Perth	79
Bangkok	84	Hong Kong	70	Rhodes	54
Calcutta	73	Jerusalem	61	Sydney	81
Dallas	57	Luxembourg	34	Tenerife	68
Frankfurt	34	Melbourne	77	Wellington	63

(a) Draw an ordered stem and leaf diagram to show these 15 temperatures.

.....	<table style="border-collapse: collapse; width: 100%; height: 100%;"> <tr><td style="border-right: 1px solid black; width: 10%;"></td><td style="border-top: 1px solid black; width: 90%;"></td></tr> <tr><td style="border-right: 1px solid black;"></td><td style="border-top: 1px solid black;"></td></tr> <tr><td style="border-right: 1px solid black;"></td><td style="border-top: 1px solid black;"></td></tr> <tr><td style="border-right: 1px solid black;"></td><td style="border-top: 1px solid black;"></td></tr> <tr><td style="border-right: 1px solid black;"></td><td style="border-top: 1px solid black;"></td></tr> <tr><td style="border-right: 1px solid black;"></td><td style="border-top: 1px solid black;"></td></tr> <tr><td style="border-right: 1px solid black;"></td><td style="border-top: 1px solid black;"></td></tr> </table>														

Key: **[3]**

(b) Josh chose 15 places each beginning with a different letter of the alphabet. Suppose Josh had chosen Lisbon instead of Luxembourg to show in his table. The temperature for Lisbon was 57 °F.

Explain what effect this change would have on the mode and the median temperatures.

.....

Effect on mode _____

Effect on median _____

[2]

5 In the year 2000 the average price of a house in the United Kingdom was £81 600.

(a) By 2005 the average price of a house had increased by 93%.

Find the average price of a house in 2005.

.....
.....
.....
.....

(a) £ _____ [3]

(b) In 1995 the average price of a house was £50 900.

Find the percentage increase in the average price of a house from 1995 to 2000.

.....
.....
.....
.....

(b) _____ % [3]

- 6 (a) Solve this inequality.

$$4x - 1 < 20$$

.....
.....
.....

(a) _____ [2]

- (b) You are given also that $x > 0$ and that x is a whole number.

Write down all the possible values of x .

.....
.....

(b) _____ [1]

7 Here is a regular pentagon.

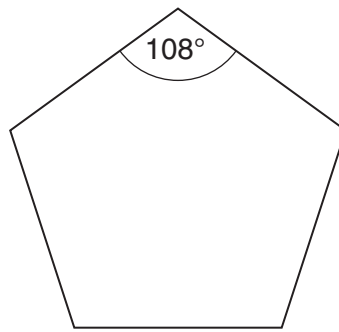

(a) Show that each interior angle is 108° .

[2]

(b) The sides of a regular pentagon are extended to make this shape.

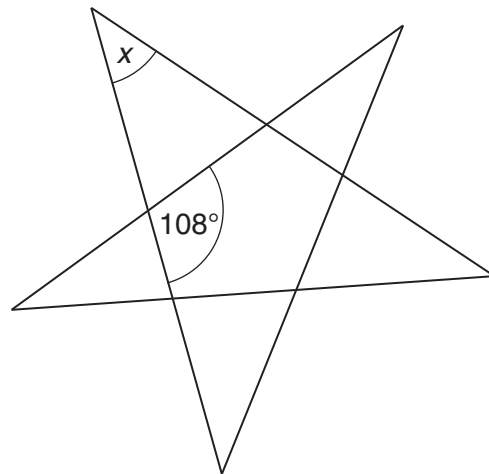

NOT TO
SCALE

Calculate the size of angle x .

(b) _____ $^\circ$ [3]

(c) Here is another regular pentagon.

Using ruler and compasses, construct the bisector of angle C.
You must leave in your construction lines.

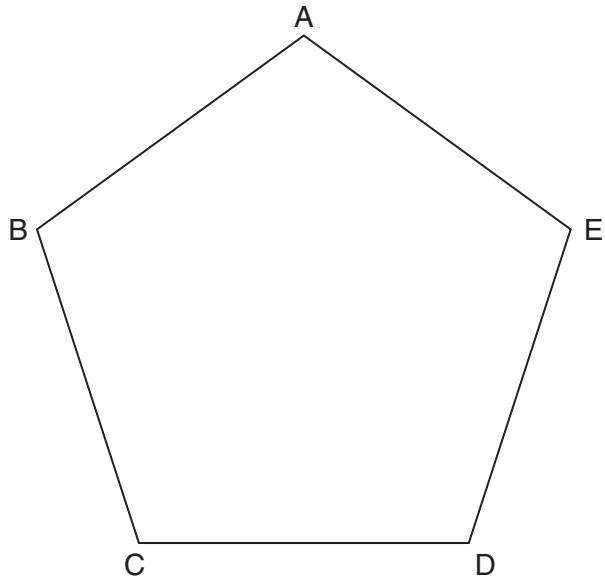

[2]

8 Use trial and improvement to solve this equation.

$$x^3 - 2x = 7$$

Give your answer to 1 decimal place.
Show all your trials and their outcomes.

.....

.....

.....

.....

.....

.....

.....

.....

.....

.....

_____ [4]

9 (a) Complete this table for $y = 2x^2 - 6x - 1$.

x	-0.5	0	0.5	1	1.5	2	2.5	3	3.5
y	2.5	-1		-5	-5.5		-3.5	-1	2.5

[1]

(b) Draw the graph of $y = 2x^2 - 6x - 1$ for $-0.5 \leq x \leq 3.5$.

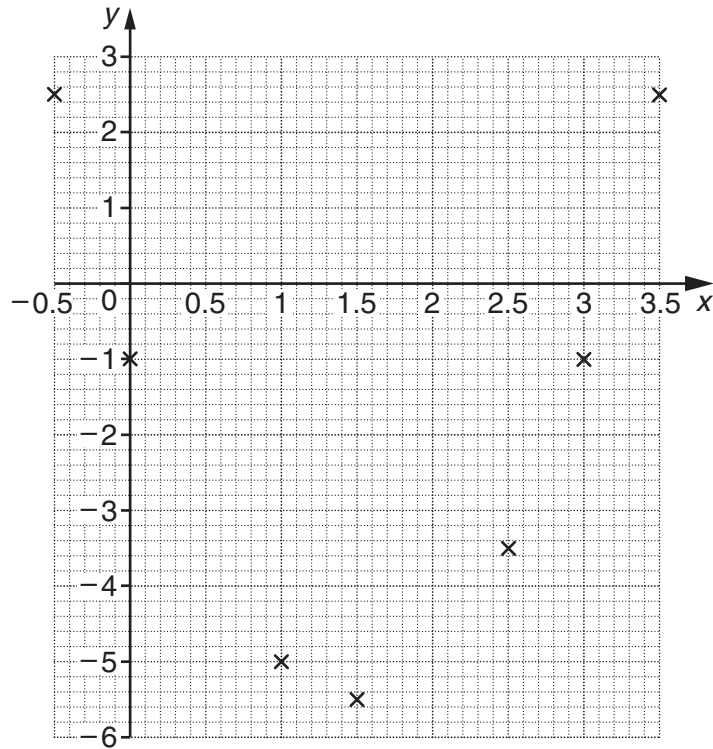

[2]

(c) On the grid, draw the line $y = 2x - 5$.

.....
 [3]

(d) Use your graphs to solve $2x^2 - 6x - 1 = 2x - 5$.

.....
 (d) _____ [2]

(e) Show that $2x^2 - 6x - 1 = 2x - 5$ can be simplified to $x^2 - 4x + 2 = 0$.

[1]

(f) Solve $x^2 - 4x + 2 = 0$, giving your answers correct to 3 decimal places.

.....

.....

.....

.....

.....

.....

.....

.....

(f) _____ [3]

10 (a) The circumference of a circle is 25.8 cm.

Calculate the radius of the circle.
Give your answer to an appropriate degree of accuracy.

.....
.....
.....

(a) _____ cm [3]

(b) A semi-circle has radius 6.1 cm.

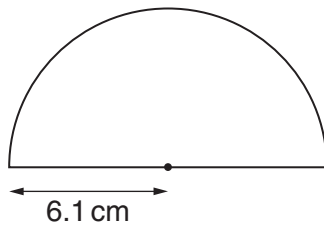

Calculate the area of the semi-circle.

.....
.....
.....
.....

(b) _____ cm² [2]

13 (a) Factorise completely.

(i) $x^2 - 36$

.....

(a)(i) _____ [1]

(ii) $8x^2 + 12xy$

.....

.....

(ii) _____ [2]

(b) Rearrange this formula to make c the subject.

$$E = mc^2$$

.....

.....

.....

.....

(b) _____ [2]

14 (a) Write each of these numbers in standard form.

(i) 320 000

.....

(a)(i) _____ [1]

(ii) $\frac{1}{40}$

.....

(ii) _____ [1]

(b) Multiply 3.6×10^7 by 7.5×10^{12} .
Give your answer in standard form.

.....

.....

.....

(b) _____ [2]

- 15 Reuben plays a game on his computer 12 times.
The graph shows the relative frequency of Reuben winning the game after each of the first 12 games.

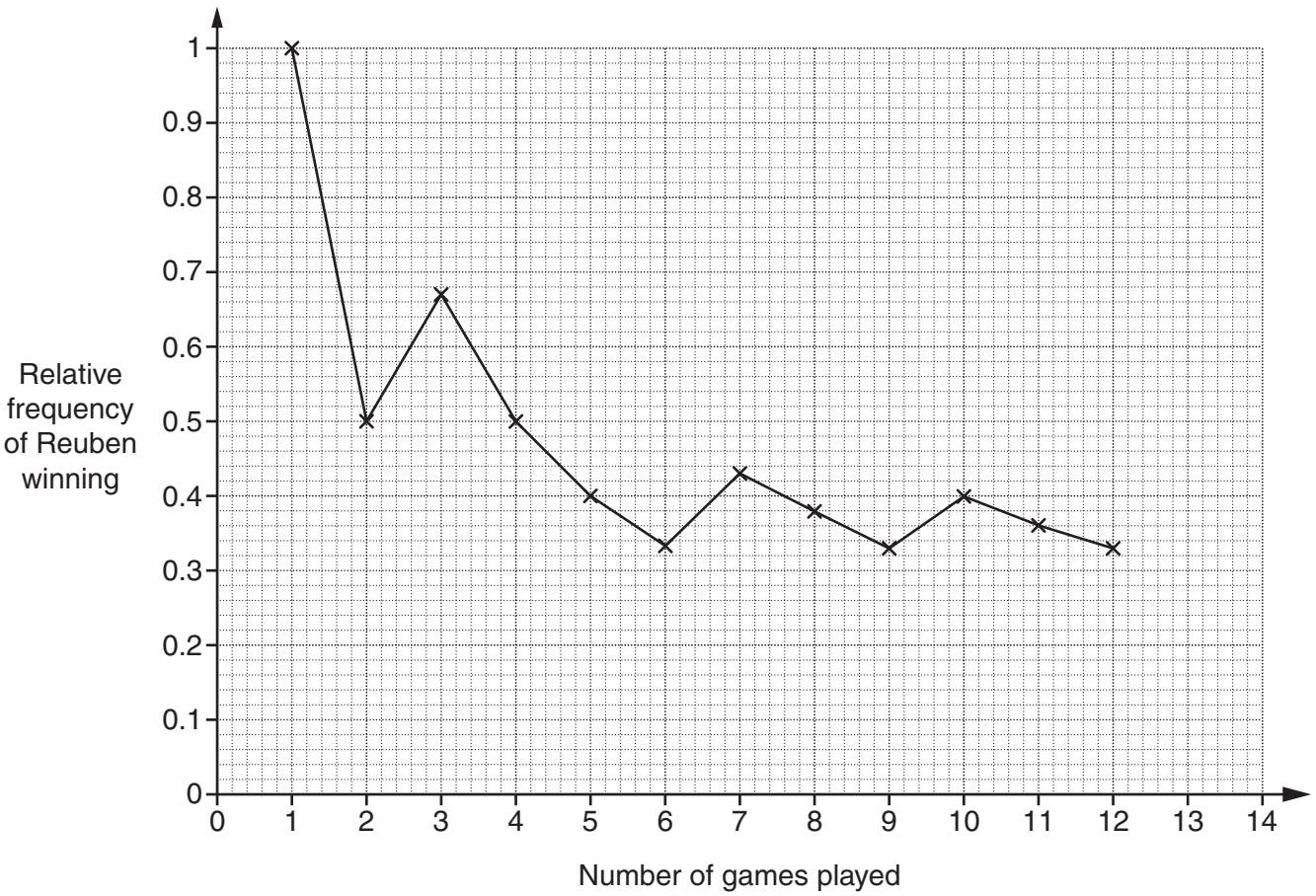

- (a) (i) Reuben won the first game, but lost the second.

How can you tell this from the graph?

[1]

- (ii) Did Reuben win or lose the third game?
Did Reuben win or lose the fourth game?

.....

.....

Third game _____ Fourth game _____ [1]

(b) Reuben is going to play the game for a 13th time.

Use the graph to estimate the probability that Reuben will win the 13th game.

.....
.....

(b) _____ [1]

(c) Reuben played the game a 13th and a 14th time and won each of these two games.

Add the relative frequencies for these two games to the graph.

.....
.....
..... [3]

16 The weights of two candles are measured as 258g and 143g both correct to the nearest gram.

(a) What is the minimum possible total weight of both candles?

.....

(a) _____ g [1]

(b) What is the maximum possible difference in weight between the two candles?

.....
.....

(b) _____ g [2]

17 (a) Calculate AB.

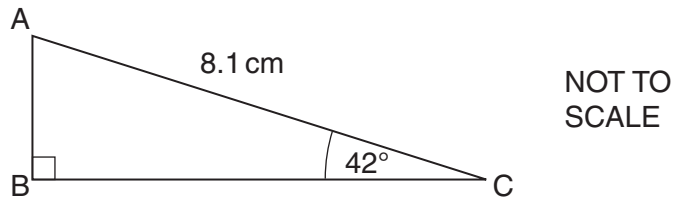

.....

.....

.....

.....

.....

(a) _____ cm [3]

(b) Calculate QR.

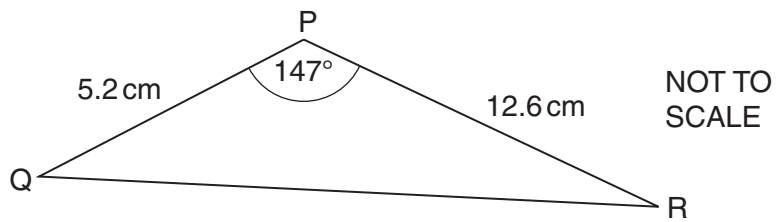

.....

.....

.....

.....

.....

(b) _____ cm [3]

(c) Calculate angle x .

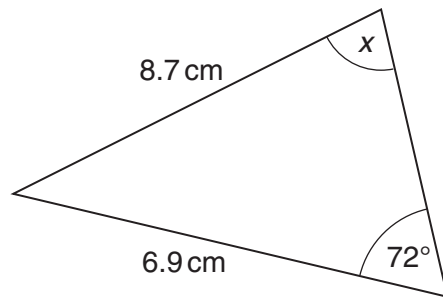

NOT TO
SCALE

.....

.....

.....

.....

.....

(c) _____ $^\circ$ [3]

- 18 (a) The histogram summarises the distances in miles travelled to work each day by a group of city workers.

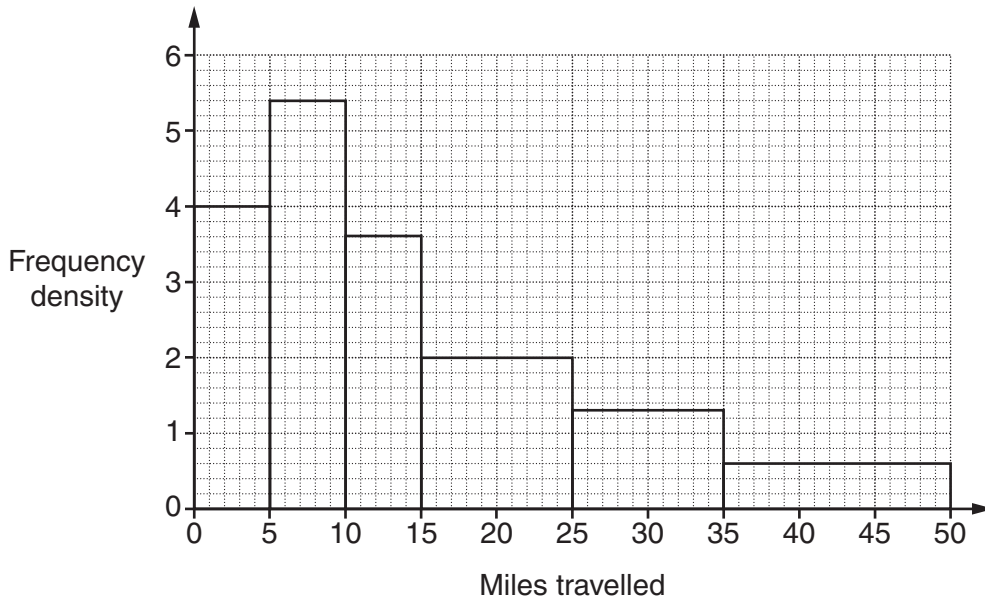

Work out an estimate of the number of these city workers who travelled more than 20 miles to work each day.

.....

.....

.....

.....

.....

(a) _____ [3]

(b) The table shows the number of unemployed people in a city.

Age (years)	Number unemployed
16 – 19	34 800
20 – 24	19 300
25 – 34	8 600
35 – 49	7 500
50 +	4 200

(i) What further information is needed in order to draw a histogram for these data?

_____ [1]

(ii) Suggest a suitable value for the missing information and give a reason why you chose this value.

_____ [1]

19 The diagram shows the net of cone A.

NOT TO SCALE

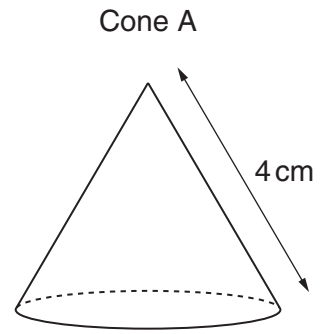
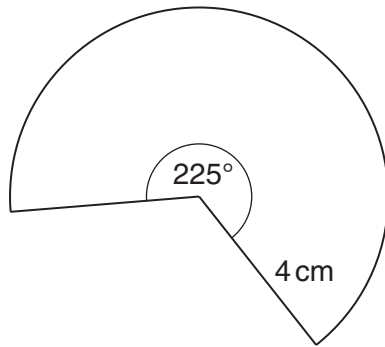

(a) (i) Show that the radius of the base of cone A is 2.5 cm .

[2]

(ii) Calculate the volume of cone A.

.....

.....

.....

.....

.....

(a)(ii) _____ cm^3 [4]

(b) Cone B is made from a mathematically similar net. This net is an enlargement of the original net, with length scale factor 3.

Complete the following.

.....

.....

(b) Volume of cone A : Volume of cone B = 1 : _____ [1]

BLANK PAGE

PLEASE DO NOT WRITE ON THIS PAGE

PLEASE DO NOT WRITE ON THIS PAGE



Copyright Information

OCR is committed to seeking permission to reproduce all third-party content that it uses in its assessment materials. OCR has attempted to identify and contact all copyright holders whose work is used in this paper. To avoid the issue of disclosure of answer-related information to candidates, all copyright acknowledgements are reproduced in the OCR Copyright Acknowledgements Booklet. This is produced for each series of examinations, is given to all schools that receive assessment material and is freely available to download from our public website (www.ocr.org.uk) after the live examination series.

If OCR has unwittingly failed to correctly acknowledge or clear any third-party content in this assessment material, OCR will be happy to correct its mistake at the earliest possible opportunity.

For queries or further information please contact the Copyright Team, First Floor, 9 Hills Road, Cambridge CB2 1GE.

OCR is part of the Cambridge Assessment Group; Cambridge Assessment is the brand name of University of Cambridge Local Examinations Syndicate (UCLES), which is itself a department of the University of Cambridge.