

GENERAL CERTIFICATE OF SECONDARY EDUCATION

MATHEMATICS SYLLABUS A

J512/04

Paper 4 (Higher Tier)

Candidates answer on the Question Paper

OCR Supplied Materials:

None

Other Materials Required:

- Electronic calculator
- Geometrical instruments
- Tracing paper (optional)

Friday 11 June 2010

Morning

Duration: 2 hours



Candidate Forename		Candidate Surname	
--------------------	--	-------------------	--

Centre Number						Candidate Number				
---------------	--	--	--	--	--	------------------	--	--	--	--

MODIFIED LANGUAGE

INSTRUCTIONS TO CANDIDATES

- Write your name clearly in capital letters, your Centre Number and Candidate Number in the boxes above.
- Use black ink. Pencil may be used for graphs and diagrams only.
- Read each question carefully and make sure that you know what you have to do before starting your answer.
- Show your working. Marks may be given for a correct method even if the answer is incorrect.
- Answer **all** the questions.
- Do **not** write in the bar codes.
- Write your answer to each question in the space provided. Additional paper may be used if necessary but you must clearly show your Candidate Number, Centre Number and question number(s).

INFORMATION FOR CANDIDATES

- The number of marks is given in brackets [] at the end of each question or part question.
- You are expected to use an electronic calculator for this paper.
- Use the π button on your calculator or take π to be 3.142 unless the question says otherwise.
- The total number of marks for this paper is **100**.
- This document consists of **20** pages. Any blank pages are indicated.

Formulae Sheet: Higher Tier

Area of trapezium = $\frac{1}{2}(a + b)h$

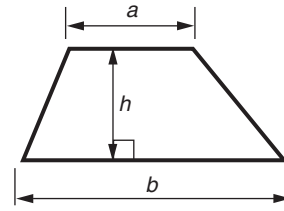

Volume of prism = (area of cross-section) \times length

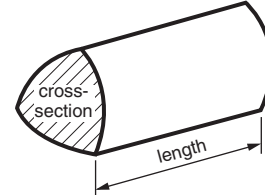

In any triangle ABC

Sine rule $\frac{a}{\sin A} = \frac{b}{\sin B} = \frac{c}{\sin C}$

Cosine rule $a^2 = b^2 + c^2 - 2bc \cos A$

Area of triangle = $\frac{1}{2}ab \sin C$

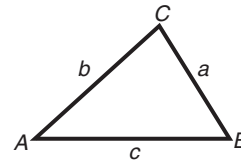

Volume of sphere = $\frac{4}{3}\pi r^3$

Surface area of sphere = $4\pi r^2$

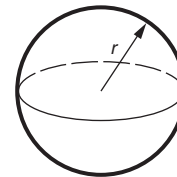

Volume of cone = $\frac{1}{3}\pi r^2 h$

Curved surface area of cone = $\pi r l$

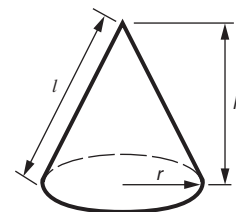

The Quadratic Equation

The solutions of $ax^2 + bx + c = 0$,
where $a \neq 0$, are given by

$$x = \frac{-b \pm \sqrt{b^2 - 4ac}}{2a}$$

PLEASE DO NOT WRITE ON THIS PAGE

1 Calculate.

(a) $\frac{31.8 \times 0.4}{5.3 - 2.8}$

.....

(a) _____ [2]

(b) $\sqrt{4.7^3}$

Give your answer correct to 2 decimal places.

.....

(b) _____ [2]

2 Reuben bought 2 bars of chocolate and 44 jelly snakes.
 The chocolate bars cost 84 pence each and the jelly snakes cost x pence each.

(a) Write down an expression for the total cost, in pence.

.....

(a) _____ [1]

Reuben spent £5.20 altogether.

(b) Write down an equation and solve it to find the cost of one jelly snake.

.....

(b) _____ pence [3]

- 3 The diagram shows the positions of a phone mast, P, and a school, S.



- (a) Find the bearing of the phone mast from the school.

.....
 (a) _____ ° [1]

- (b) Richard cycles from the school, in a straight line, on a bearing of 320° .

(i) Draw a line to show Richard's route. [1]

(ii) Mark a point X on the line where Richard is closest to the phone mast. [1]

- (iii) What should angle PXS be?

.....
 (b) (iii) _____ [1]

4 (a) ABCD is a trapezium.

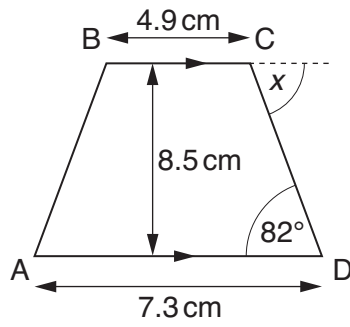

NOT TO SCALE

(i) Work out the area of ABCD.

.....

.....

.....

(a)(i) _____ cm² [2]

(ii) Find the size of angle x .
Give a reason for your answer.

$x =$ _____ $^{\circ}$ because _____

_____ [2]

(b) This diagram shows a square between two parallel lines.

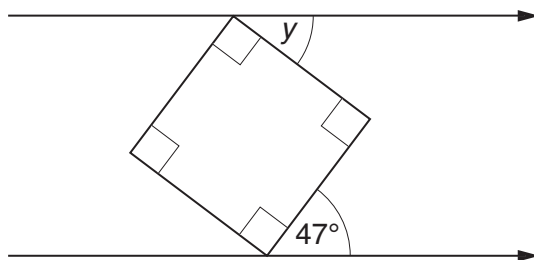

NOT TO SCALE

Find the size of angle y .

.....

(b) _____ $^{\circ}$ [2]

5 Josh completed a mini-triathlon in which he swam, cycled and ran.

(a) Josh swam 0.75 km in 15 minutes.

Calculate the average speed for his swim.

.....

.....

.....

.....

(a) _____ km/h [3]

(b) This distance-time graph represents his cycling stage.

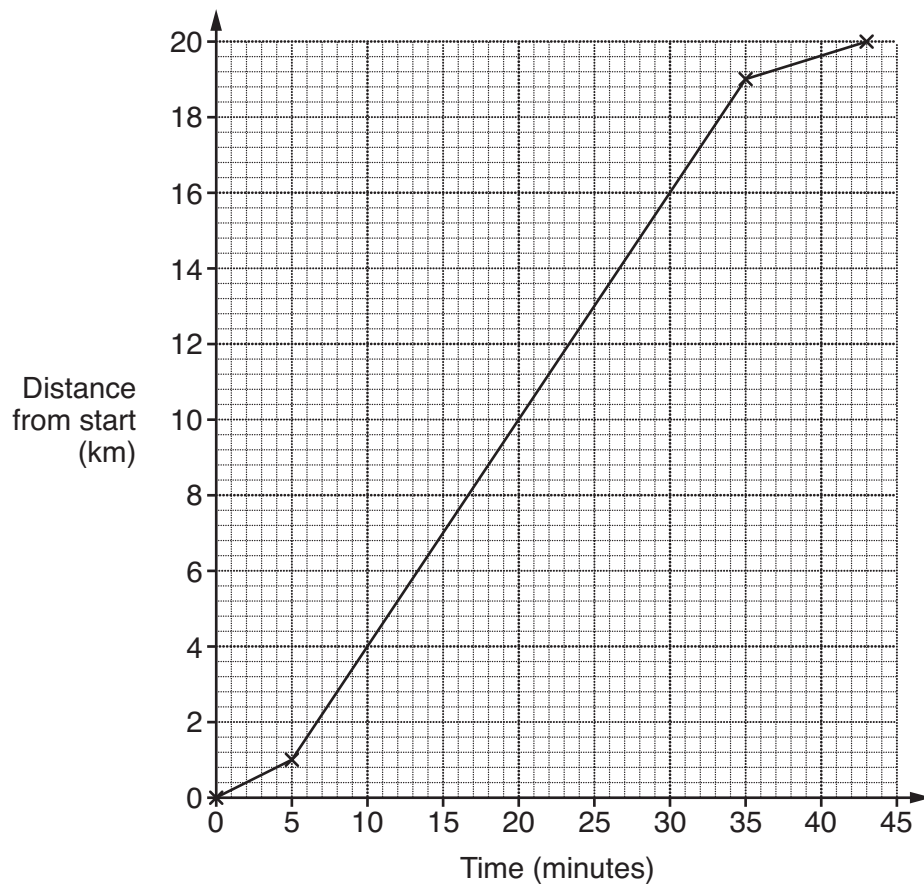

Between which times did Josh cycle fastest?

.....

.....

(b) _____ minutes and _____ minutes [1]

(c) Josh completed the 5 km run at an average speed of 12 km/h.

How long altogether did Josh take to complete the mini-triathlon?

.....
.....
.....
.....
.....
.....

(c) _____ minutes [4]

6 In this question, n is an integer.

Which of these statements describes $5n + 1$?

always even

always odd

sometimes odd, sometimes even

Explain how you decided.

.....
.....
.....

$5n + 1$ is _____

because _____

_____ [2]

7 Solve.

(a) $3x - 5 = x + 4$

.....
.....
.....

(a) _____ [3]

(b) $\frac{x}{3} - 2 = 70$

.....
.....

(b) _____ [2]

(c) $5x + 6 > 28$

.....
.....

(c) _____ [2]

- 8 A block of wood is in the shape of a prism.
Its cross-section is a parallelogram as shown.

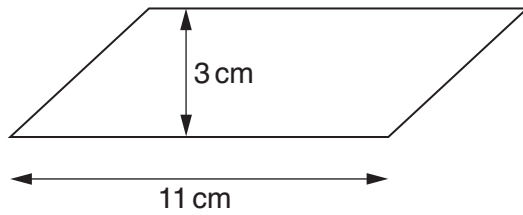

NOT TO SCALE

The length of the prism is 6 cm.

Calculate the volume of the block of wood.

.....

.....

.....

.....

_____ cm³ [3]

- 9 (a) (i) Write 36 as a product of prime factors.

.....

.....

(a) (i) _____ [2]

- (ii) Explain how your answer to part (a)(i) shows that 36 is a square number.

_____ [1]

- (b) What is the smallest whole number you need to multiply 350 by to get a square number?

.....

.....

.....

.....

.....

(b) _____ [3]

- 10 Lilia kept a record of the number of miles she travelled in her car each day in July, August and September.

The table summarises the data for July.

Miles travelled (m)	Frequency
$0 \leq m < 10$	5
$10 \leq m < 20$	9
$20 \leq m < 30$	11
$30 \leq m < 40$	4
$40 \leq m < 50$	2

- (a) Work out an estimate of the mean daily number of miles travelled in July.

.....

.....

.....

.....

.....

.....

(a) _____ miles [4]

- (b) Draw a frequency polygon for the data for July.

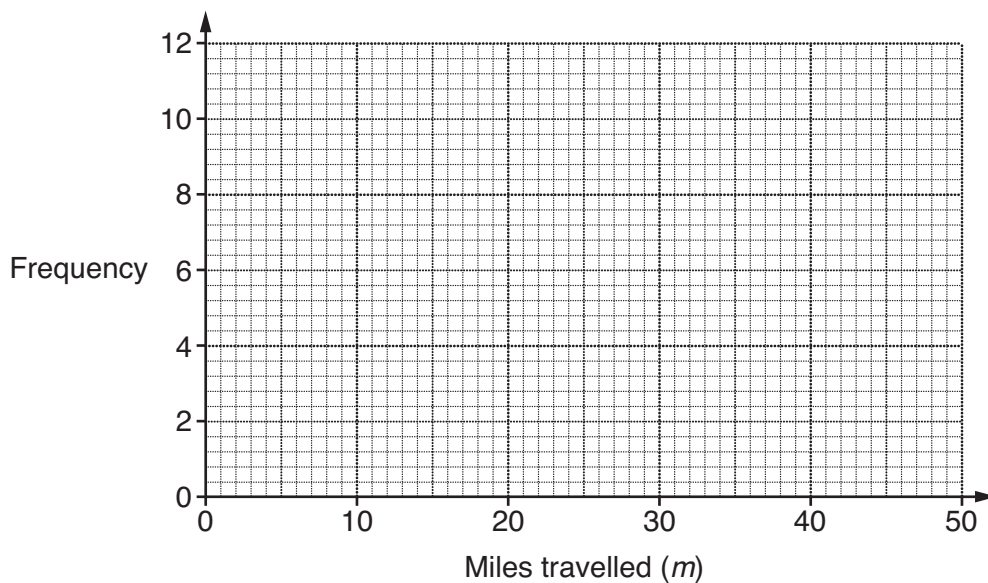

[2]

(c) This graph summarises the data for August.

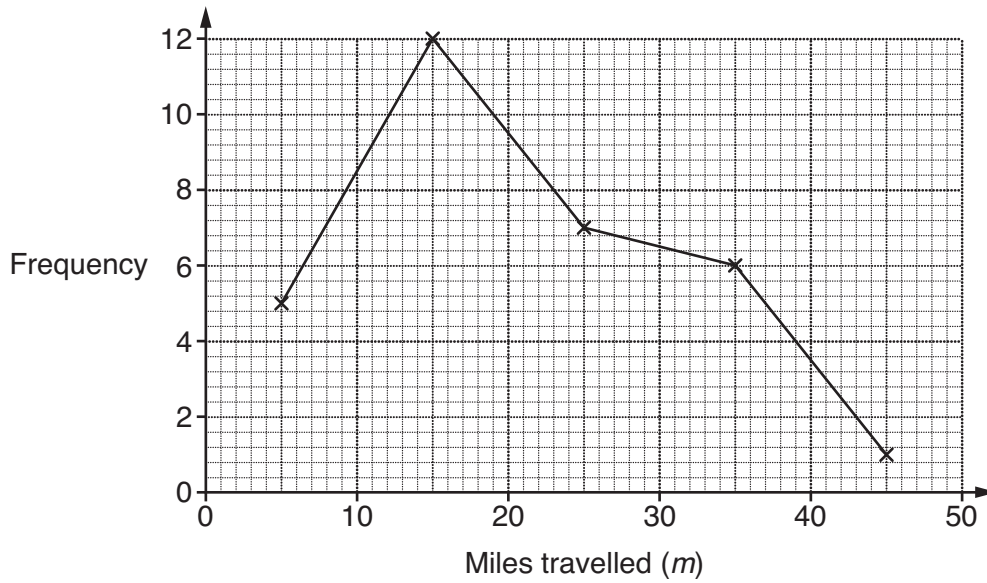

(i) What is the modal class interval?

(c)(i) _____ [1]

(ii) Which class interval contains the median?

(ii) _____ [1]

(d) Write down one difference between the daily number of miles Lilia travelled in July and in August.

_____ [1]

(e) This table summarises the data for the first 29 days in September.

Miles travelled (m)	Frequency
$0 \leq m < 10$	7
$10 \leq m < 20$	8
$20 \leq m < 30$	10
$30 \leq m < 40$	3
$40 \leq m < 50$	1

(i) How many miles could Lilia travel on the 30th day in September so that the class interval in which the median for September lies does not change?
Explain how you worked out your answer.

.....

.....

_____ miles because _____

_____ [2]

(ii) In fact, Lilia travelled 40 miles on the 30th day in September.

In which class interval should this distance be recorded?

(e)(ii) _____ [1]

11 (a) Complete this table for $y = x^3 - 4x + 1$.

x	-2.5	-2	-1.5	-1	-0.5	0	0.5	1	1.5	2
y	-4.625	1	3.625		2.875	1	-0.875	-2		1

.....
 [2]

(b) Plot the remaining points and draw the graph of $y = x^3 - 4x + 1$ for $-2.5 \leq x \leq 2$.

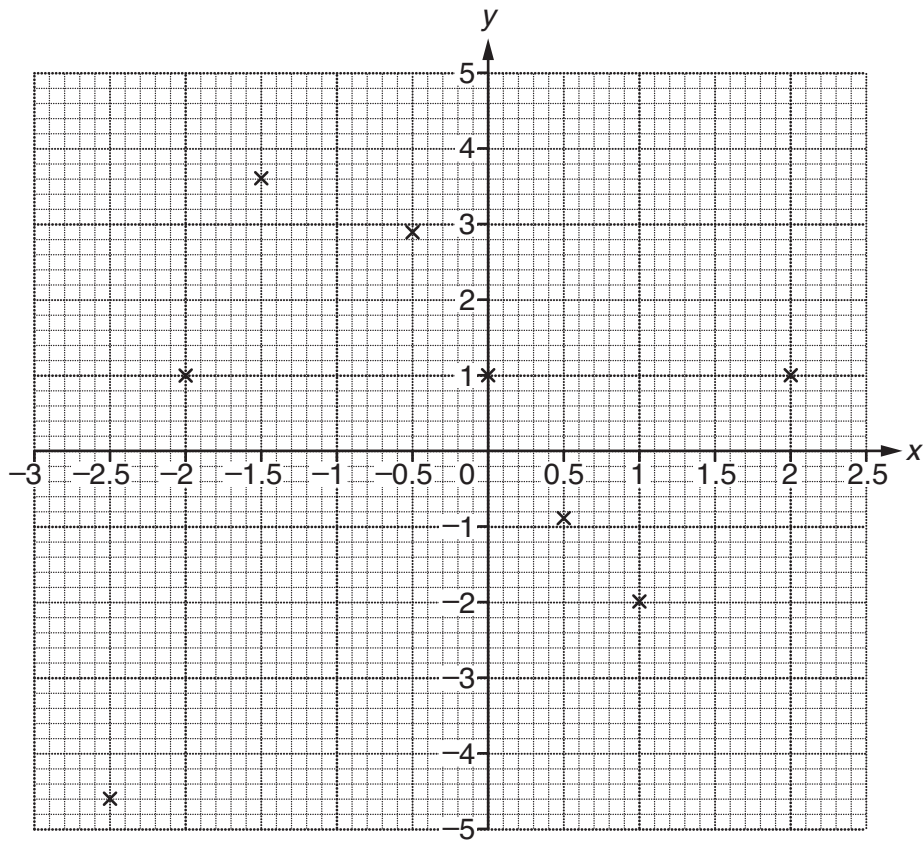

[2]

(c) Use your graph to estimate the value of x when $y = -3$.

.....
 (c) _____ [1]

12 Solve algebraically these simultaneous equations.

$$4x + 3y = 19$$

$$6x + 2y = 11$$

.....

.....

.....

.....

.....

.....

$$x = \underline{\hspace{2cm}} \quad y = \underline{\hspace{2cm}} \quad [4]$$

13 £1000 was invested for one year at a fixed annual rate of interest.
20% tax was deducted from the interest before it was paid.
The amount of interest paid was £52.

Calculate the rate of interest before tax was deducted.

.....

.....

.....

.....

.....

.....

$$\underline{\hspace{2cm}} \% [4]$$

14 (a) Simplify.

(i) $\frac{x^6y^4}{x^2}$

.....

(a)(i) _____ [1]

(ii) $(3x^4y)^2$

.....

(ii) _____ [2]

(b) Solve, giving your answers correct to 2 decimal places.

$$x^2 - 25x + 19 = 0$$

.....

(b) _____ [3]

(c) y is inversely proportional to x and $y = 196$ when $x = 4$.

Find an equation connecting x and y .

.....

(c) _____ [2]

15 (a) Calculate the size of angle x .

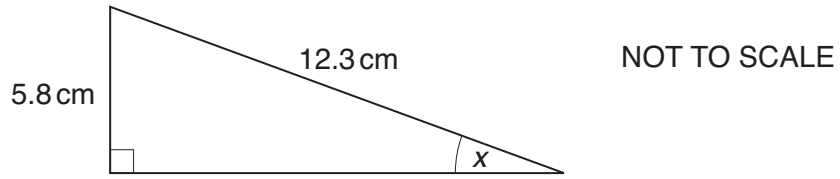

.....

.....

.....

.....

.....

.....

.....

(a) _____ ° [3]

(b) Calculate the length AB.

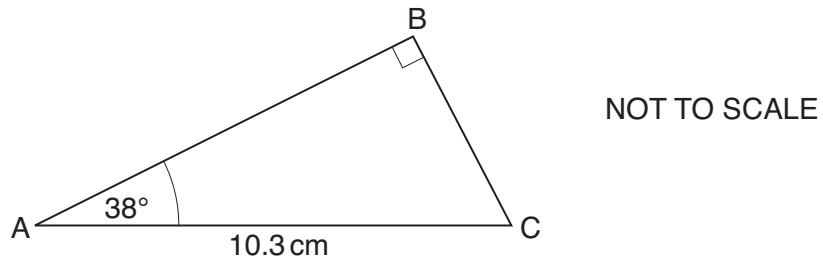

.....

.....

.....

.....

.....

.....

.....

(b) _____ cm [3]

(c) Calculate the area of triangle PQR.

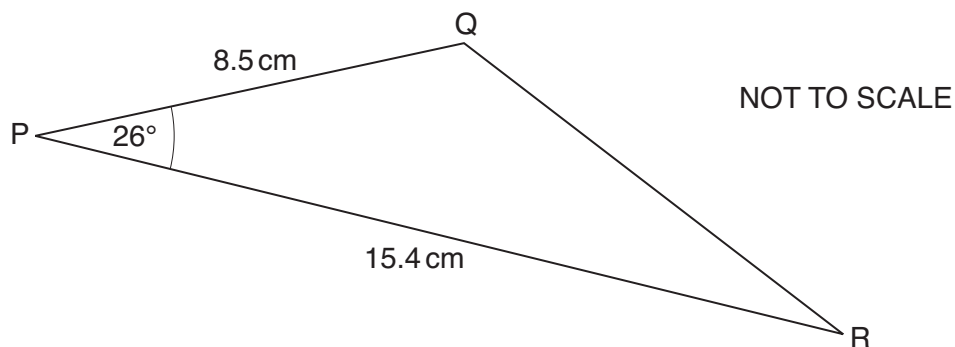

.....

.....

.....

.....

.....

.....

(c) _____ cm^2 [2]

- 16 A satellite travels round the Earth in a path which is taken to be a circle of radius 6800 km.

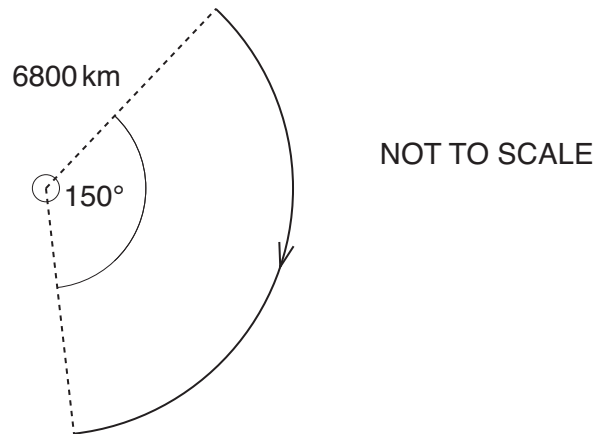

Calculate the distance that the satellite travels when it moves through an angle of 150°. Give your answer to a suitable degree of accuracy.

.....

.....

.....

.....

.....

.....

_____ km [4]

- 17 Regulations state that ramps for electric wheelchairs must make an angle with the horizontal of less than 7.2° .

The diagram shows a ramp with dimensions that were measured to the nearest 10 centimetres.

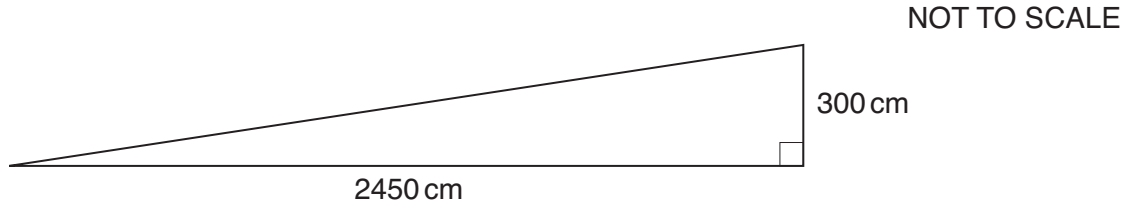

Is it certain that this ramp satisfies the regulations for electric wheelchairs?
You must support your answer with working.

[5]

TURN OVER FOR QUESTION 18

- 18** A bag contains 3 yellow counters and 5 green counters.
 A counter is taken at random from the bag and is not replaced.
 A second counter is then taken at random from the bag.

(a) Complete the tree diagram to show the probabilities of taking yellow and green counters.

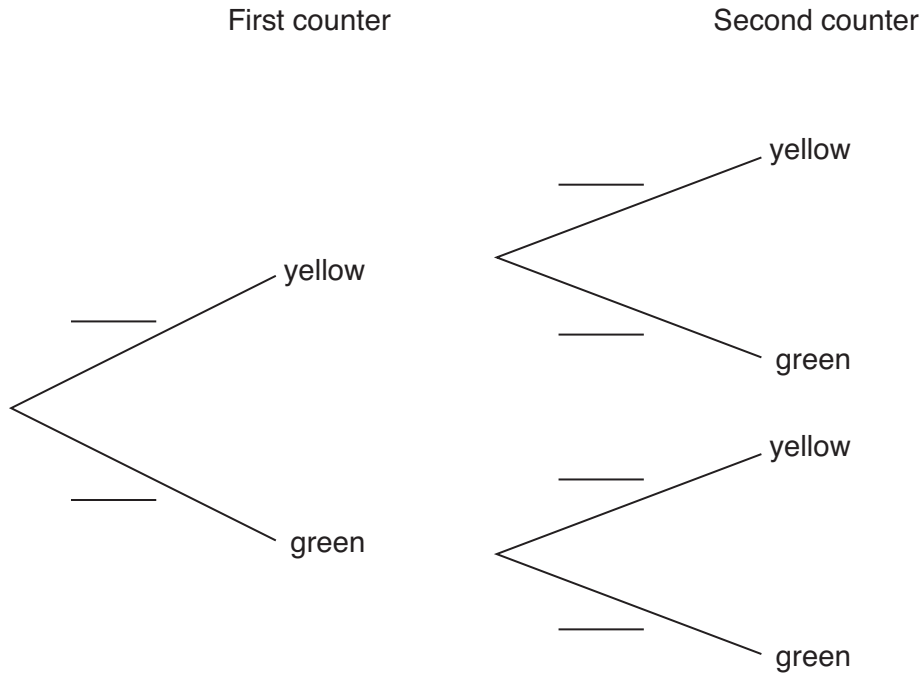

[3]

(b) Work out the probability that the counters taken are different colours.

.....

.....

.....

.....

.....

.....

(b) _____ [3]



Copyright Information

OCR is committed to seeking permission to reproduce all third-party content that it uses in its assessment materials. OCR has attempted to identify and contact all copyright holders whose work is used in this paper. To avoid the issue of disclosure of answer-related information to candidates, all copyright acknowledgements are reproduced in the OCR Copyright Acknowledgements Booklet. This is produced for each series of examinations, is given to all schools that receive assessment material and is freely available to download from our public website (www.ocr.org.uk) after the live examination series.

If OCR has unwittingly failed to correctly acknowledge or clear any third-party content in this assessment material, OCR will be happy to correct its mistake at the earliest possible opportunity.

For queries or further information please contact the Copyright Team, First Floor, 9 Hills Road, Cambridge CB2 1GE.

OCR is part of the Cambridge Assessment Group; Cambridge Assessment is the brand name of University of Cambridge Local Examinations Syndicate (UCLES), which is itself a department of the University of Cambridge.