

Write your name here

Surname

Other names

Pearson
Edexcel GCSE

Centre Number

--	--	--	--	--

Candidate Number

--	--	--	--

Applications of Mathematics

Unit 2: Applications 2

For Approved Pilot Centres ONLY

Higher Tier

Thursday 8 June 2017 – Morning

Time: 1 hour 45 minutes

Paper Reference

5AM2H/01

You must have: Ruler graduated in centimetres and millimetres, protractor, pair of compasses, pen, HB pencil, eraser, calculator. Tracing paper may be used.

Total Marks

--

Instructions

- Use **black** ink or ball-point pen.
- **Fill in the boxes** at the top of this page with your name, centre number and candidate number.
- Answer **all** questions.
- Answer the questions in the spaces provided – *there may be more space than you need.*
- **Calculators may be used.**
- If your calculator does not have a π button, take the value of π to be 3.142 unless the question instructs otherwise.



Information

- The total mark for this paper is 100.
- The marks for **each** question are shown in brackets – *use this as a guide as to how much time to spend on each question.*
- Questions labelled with an **asterisk** (*) are ones where the quality of your written communication will be assessed.

Advice

- Read each question carefully before you start to answer it.
- Keep an eye on the time.
- Try to answer every question.
- Check your answers if you have time at the end.

Turn over ►

P53502A

©2017 Pearson Education Ltd.

1/6/7/5/





Pearson

GCSE Mathematics 2AM01

Formulae: Higher Tier

**You must not write on this formulae page.
Anything you write on this formulae page will gain NO credit.**

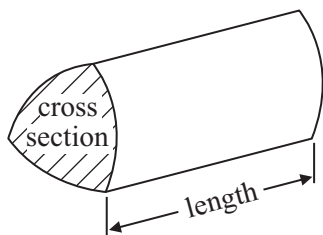
Volume of prism = area of cross section \times length



Area of trapezium = $\frac{1}{2} (a + b)h$

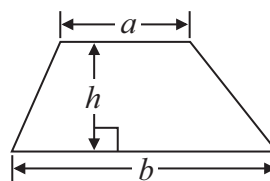

Volume of sphere = $\frac{4}{3} \pi r^3$

Surface area of sphere = $4\pi r^2$

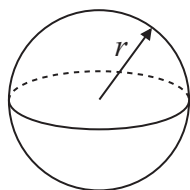

Volume of cone = $\frac{1}{3} \pi r^2 h$

Curved surface area of cone = $\pi r l$

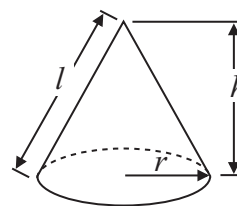

In any triangle ABC

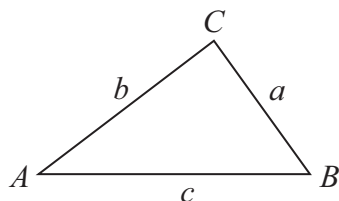

The Quadratic Equation

The solutions of $ax^2 + bx + c = 0$ where $a \neq 0$, are given by

$$x = \frac{-b \pm \sqrt{b^2 - 4ac}}{2a}$$

Sine Rule $\frac{a}{\sin A} = \frac{b}{\sin B} = \frac{c}{\sin C}$

Cosine Rule $a^2 = b^2 + c^2 - 2bc \cos A$

Area of triangle = $\frac{1}{2} ab \sin C$

DO NOT WRITE IN THIS AREA

DO NOT WRITE IN THIS AREA

DO NOT WRITE IN THIS AREA



Answer ALL questions.

Write your answers in the spaces provided.

You must write down all the stages in your working.

- 1 John buys 3 portions of chips.
The total cost is £3.45

Celia buys 1 fish and 2 portions of chips.
The total cost is £5.60

- (a) Work out the cost of the fish.

£.....
(3)

Celia and Dave share the £5.60 cost in the ratio 4 : 3

- (b) Work out how much Celia pays and how much Dave pays.

Celia £.....

Dave £.....
(3)

(Total for Question 1 is 6 marks)

DO NOT WRITE IN THIS AREA

DO NOT WRITE IN THIS AREA

DO NOT WRITE IN THIS AREA



DO NOT WRITE IN THIS AREA

DO NOT WRITE IN THIS AREA

DO NOT WRITE IN THIS AREA

2 Harry owns a factory that makes plastic toys.

Each toy is tested.

If the toy is perfect, it is put into a box.

The boxes are then put into cartons.

Each carton holds 36 boxes.

The factory makes 500 toys an hour.

2% of these toys are **not** perfect.

Toys are made for $10\frac{1}{2}$ hours each day in the factory.

How many cartons are needed each day?

You must show all your working.

.....
(Total for Question 2 is 5 marks)



DO NOT WRITE IN THIS AREA

DO NOT WRITE IN THIS AREA

DO NOT WRITE IN THIS AREA

3 Rashmi works at a home for dogs.

She has 4 types of dog food to feed the dogs.
She takes at random a tin of dog food.

The table below shows the probabilities that Rashmi will take a tin of lamb dog food or a tin of beef dog food or a tin of turkey dog food.

Dog Food	lamb	beef	chicken	turkey
Probability	0.35	0.25		0.30

(a) Work out the probability that Rashmi will take a tin of chicken dog food.

.....
(2)

(b) Work out the probability that Rashmi will take a tin of turkey dog food or a tin of lamb dog food.

.....
(2)

Rashmi has 400 tins of dog food.

(c) Work out the number of tins of lamb dog food she has.

.....
(2)

(Total for Question 3 is 6 marks)



*4 Here are the ingredients to make 12 cupcakes.

For 12 cupcakes

200 g butter
200 g caster sugar
4 eggs
250 g flour

Mark is making cupcakes to sell at his school play.

Mark wants to make 1 cupcake for each adult and 2 cupcakes for each child.

There will be 152 adults and 80 children at the school play.

Mark can get these ingredients from the school kitchen.

5 kg butter
5 kg caster sugar
90 eggs
5 kg flour

Make a shopping list of any ingredients Mark still needs, showing the amount of each ingredient.

You must show all your working.

(Total for Question 4 is 5 marks)



DO NOT WRITE IN THIS AREA

DO NOT WRITE IN THIS AREA

DO NOT WRITE IN THIS AREA

5 GasIn is an insurance company that insures central heating systems.

GasIn insures 350 000 central heating systems each year.

GasIn charges £55 to insure a central heating system for a year.

The probability that a central heating system will develop a fault is 0.18

The average claim for a central heating system fault is £273

How much profit is GasIn likely to make in a year?

£.....

(Total for Question 5 is 4 marks)



- *6 Abigail is 5 years older than Brenda.
Brenda is twice as old as Carly.

The total of their ages is less than 40

What is Abigail's greatest possible age?
Give your answer as a whole number of years.

DO NOT WRITE IN THIS AREA

DO NOT WRITE IN THIS AREA

DO NOT WRITE IN THIS AREA

(Total for Question 6 is 4 marks)



DO NOT WRITE IN THIS AREA

DO NOT WRITE IN THIS AREA

DO NOT WRITE IN THIS AREA

- 7 The diagram shows a wire frame.
The frame is a rectangle and two diagonals.

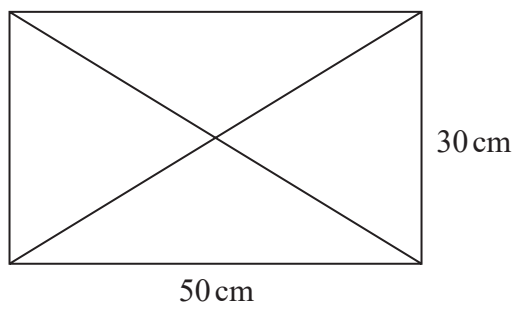

Diagram **NOT** accurately drawn

Work out the total length of the wire used to make the frame.
Give your answer correct to the nearest centimetre.

..... cm

(Total for Question 7 is 5 marks)



8 Here is a diagram of Pete's garage.

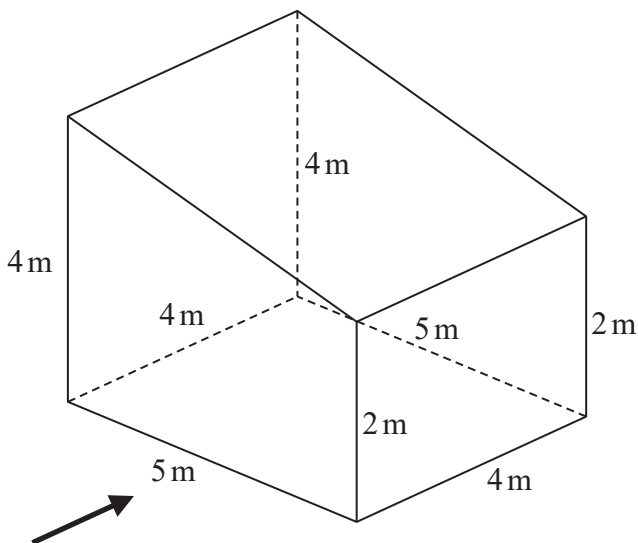
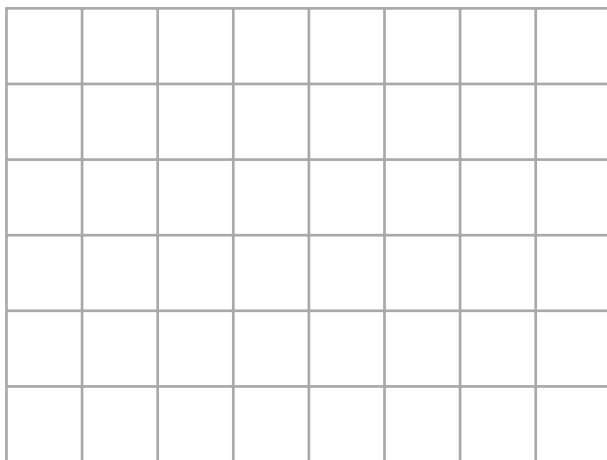

Diagram **NOT** accurately drawn

The floor of the garage is horizontal.
All the walls are vertical.

- (a) Draw the side elevation of the garage from the direction of the arrow.
Use a scale of 1 cm to 1 m.



(2)



DO NOT WRITE IN THIS AREA

DO NOT WRITE IN THIS AREA

DO NOT WRITE IN THIS AREA

Pete is going to paint the 4 walls and the ceiling of his garage.

(b) Work out an estimate for the total area he is going to paint.

..... m²

(5)

(Total for Question 8 is 7 marks)



P 5 3 5 0 2 A 0 1 1 2 4

9 The diagram shows a shape made out of solid wood.

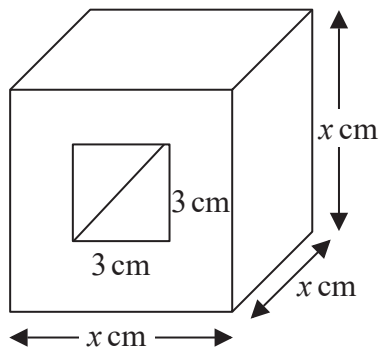

Diagram **NOT** accurately drawn

The shape is made by cutting a square hole all the way through a wooden cube.

The cube has edges of length x cm.

The hole has a square cross section of side 3 cm.

The volume of the wood in the shape is 70 cm^3 .

(a) Show that $x^3 - 9x = 70$

(2)

The equation $x^3 - 9x = 70$ has a solution between 4 and 5

(b) Use a trial and improvement method to find this solution.

Give your answer correct to 1 decimal place.

You must show **all** your working.

(4)

(Total for Question 9 is 6 marks)



DO NOT WRITE IN THIS AREA

DO NOT WRITE IN THIS AREA

DO NOT WRITE IN THIS AREA

10 Selma walked from her home to her friend's house.

The travel graph shows Selma's journey to her friend's house.

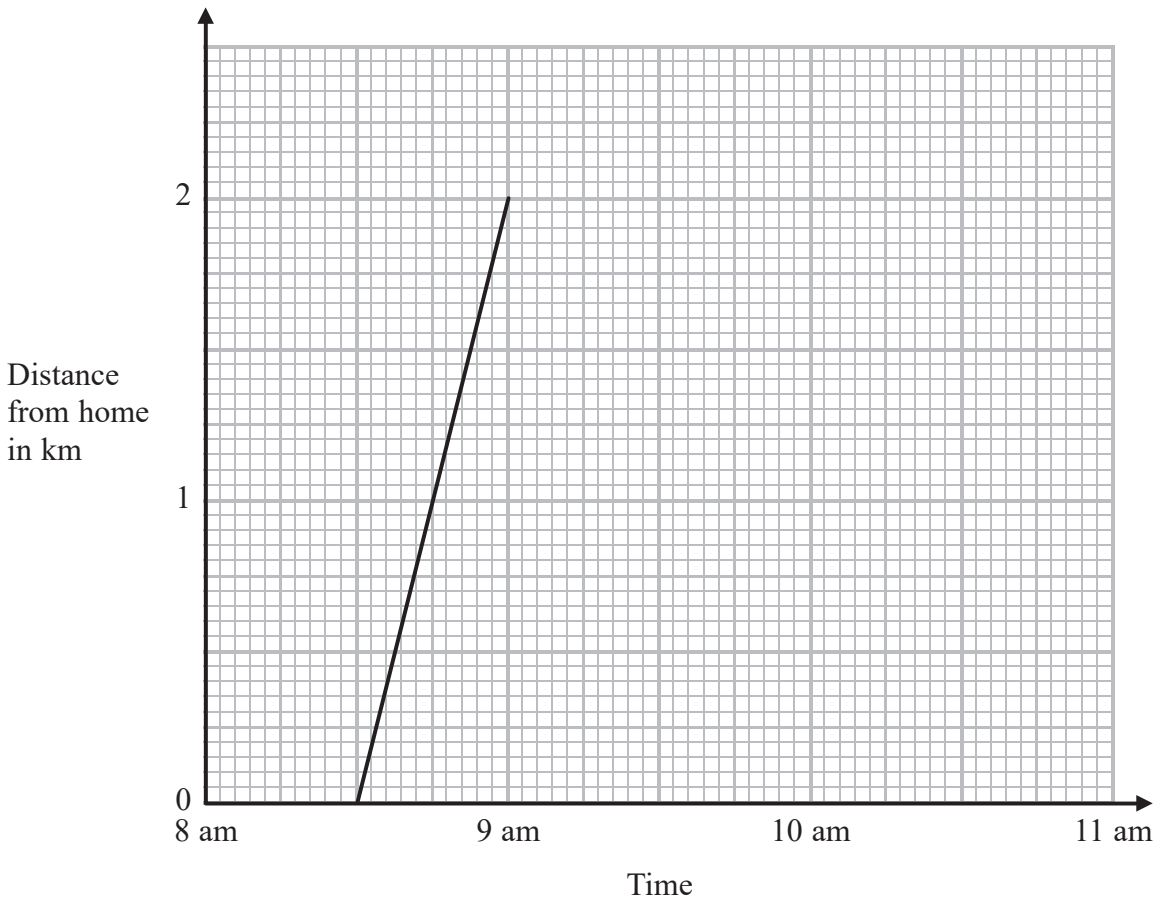

Selma spent 1 hour at her friend's house.
She then walked home at a steady speed.
Selma took 45 minutes to walk home.

(a) Complete the travel graph for this information.

(2)

(b) What was the total distance that Selma walked?

..... km

(1)

(Total for Question 10 is 3 marks)



- 11 Oil is stored in a tank at an oil refinery.
The tank is in the shape of a cylinder.

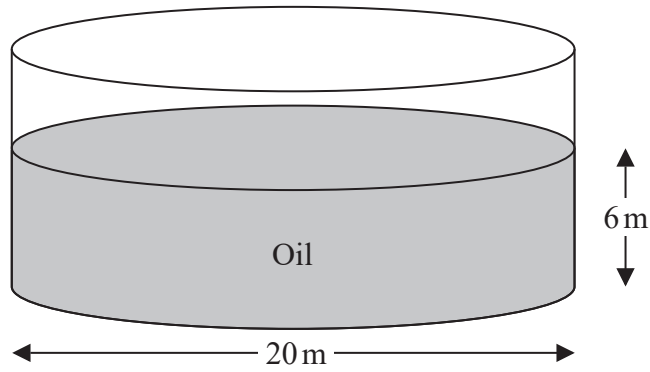

Diagram **NOT**
accurately drawn

The tank has a diameter of 20 m.
The depth of the oil in the tank is 6 m.

The density of the oil is 800 kg per m^3 .
Oil tankers can hold up to 45 000 kg of oil.

How many of these oil tankers are needed to empty all the oil from the tank?
You must show all your working.

.....
(Total for Question 11 is 5 marks)

DO NOT WRITE IN THIS AREA

DO NOT WRITE IN THIS AREA

DO NOT WRITE IN THIS AREA



DO NOT WRITE IN THIS AREA

DO NOT WRITE IN THIS AREA

DO NOT WRITE IN THIS AREA

12 Nathalie is playing a board game.
She must throw two fair 6-sided dice.

She must get a 1 on each dice to start the game.

Work out the probability that she will **not** start the game on her first go.

.....
(Total for Question 12 is 3 marks)



13 A car travels along a straight road between two sets of traffic lights.

Here is the speed-time graph for this journey.

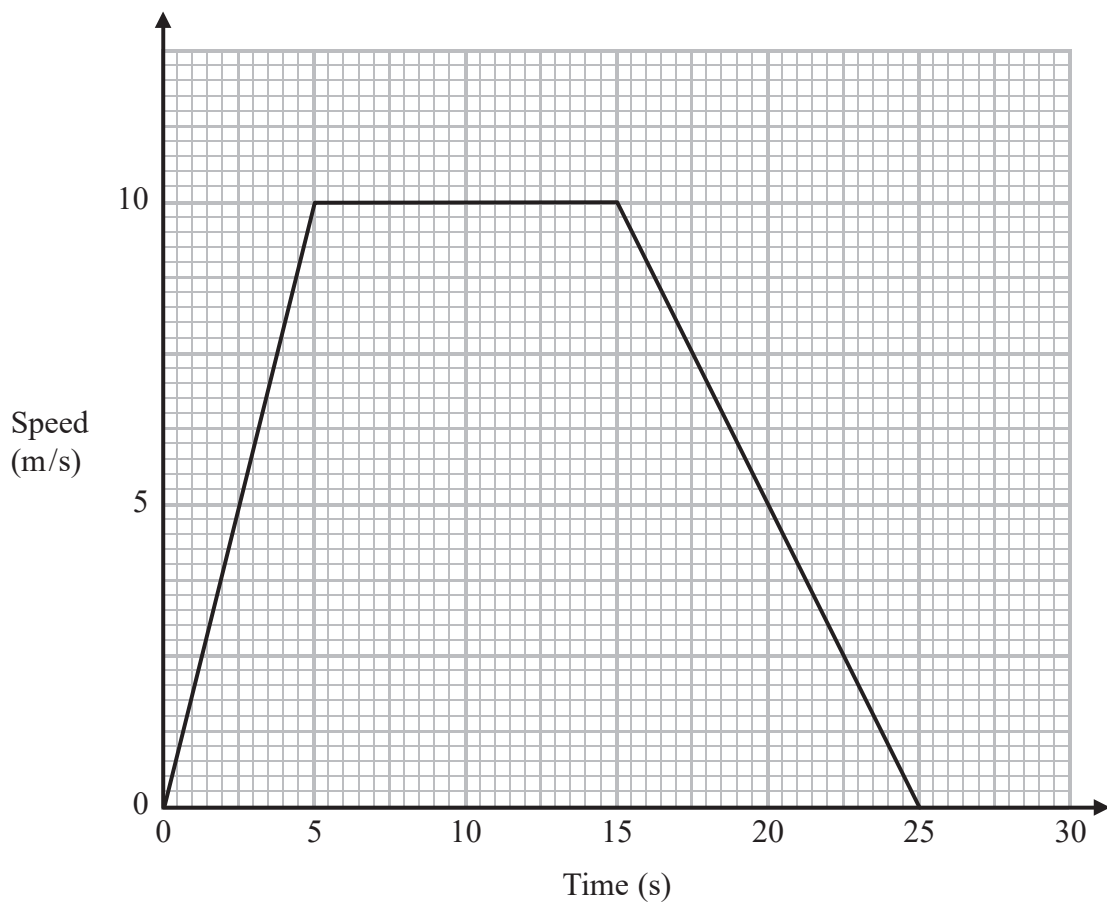

(a) Work out the acceleration of the car during the first 5 seconds.

..... m/s²
(2)

(b) Describe what happens to the speed of the car between the times of 5 s and 25 s.

.....
.....
(2)

(c) Find the total distance, in metres, that the car travels between the two sets of traffic lights.

..... m
(2)



DO NOT WRITE IN THIS AREA

DO NOT WRITE IN THIS AREA

DO NOT WRITE IN THIS AREA

(d) Work out the average speed of the car in kilometres per hour between the two sets of traffic lights.

..... km/h

(3)

(Total for Question 13 is 9 marks)



P 5 3 5 0 2 A 0 1 7 2 4

14 PQR is the side of a vertical building.

AB is a ramp.

ACP is horizontal ground.

BQ is a horizontal path.

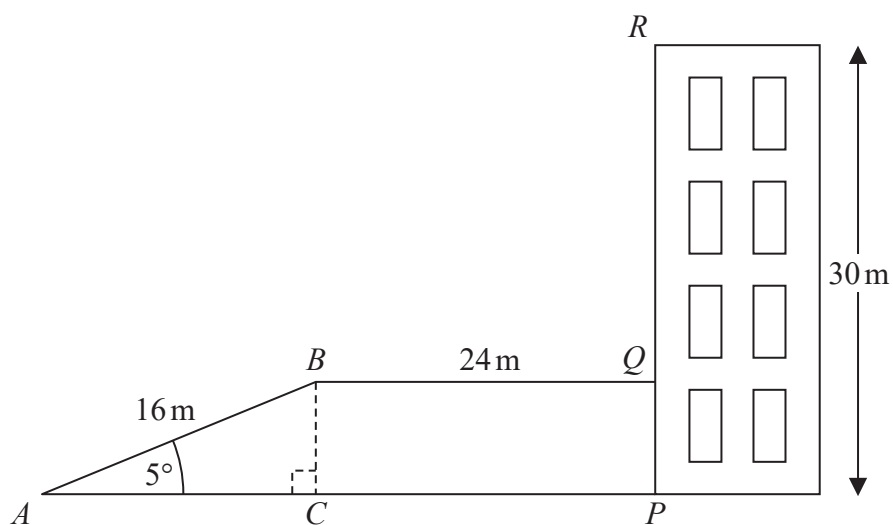

Diagram **NOT** accurately drawn

The building has a height of 30 m .

The ramp AB is at an angle of 5° to the horizontal ground.

The ramp has a length of 16 m .

The path has a length of 24 m .

- (a) Calculate the height, BC , of the ramp.
Give your answer correct to 3 significant figures.

..... m
(3)

- (b) Calculate the angle of elevation of the top of the building, R , from the top of the ramp, B .
Give your answer correct to 3 significant figures.

.....
(3)

(Total for Question 14 is 6 marks)



DO NOT WRITE IN THIS AREA

15 Jason uses the formula $R = \frac{24}{I}$ in his science lesson.

(a) Complete the table of values for $R = \frac{24}{I}$

I	1	2	4	6	8	10	12	24
R	24							1

(2)

(b) On the grid, draw the graph of $R = \frac{24}{I}$

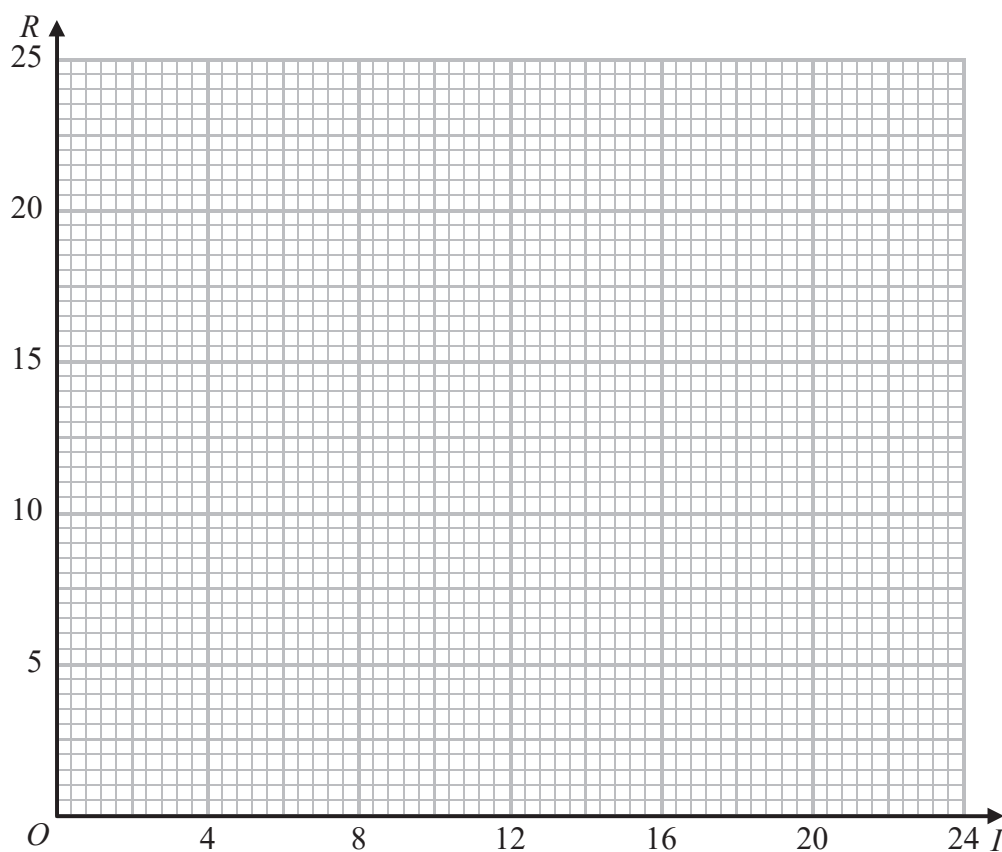

(2)

(Total for Question 15 is 4 marks)

DO NOT WRITE IN THIS AREA



P 5 3 5 0 2 A 0 1 9 2 4

*16 Here is a diagram of a room in Sammy's house.

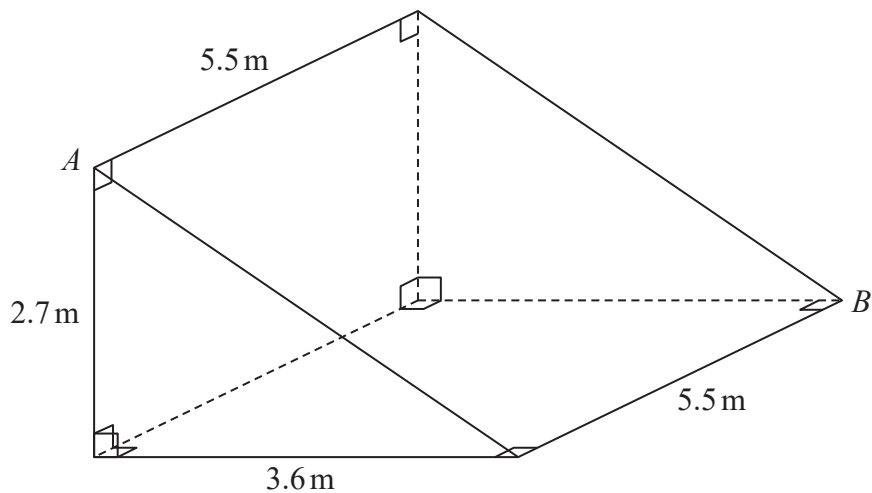

Diagram NOT accurately drawn

Sammy is putting an electric cable across the ceiling of the room. The cable will go from A to B .

Calculate the shortest possible length of the cable.
Give your answer to 3 significant figures.
You must show all your working.

DO NOT WRITE IN THIS AREA

DO NOT WRITE IN THIS AREA

DO NOT WRITE IN THIS AREA

(Total for Question 16 is 4 marks)



DO NOT WRITE IN THIS AREA

DO NOT WRITE IN THIS AREA

DO NOT WRITE IN THIS AREA

17 The time period, T , of a simple pendulum is directly proportional to the square root of the length, d , of the pendulum.

When $d = 6$, $T = 5$

Find the value of T when $d = 3$

.....
(Total for Question 17 is 4 marks)



18 A scientist is studying some rabbits.
A disease is killing the rabbits.

A population of 240 of these rabbits was reduced to 180 rabbits in two days.
The rabbit population is decreasing exponentially.

Work out how many of the 240 rabbits will still be alive at the end of 7 days.

DO NOT WRITE IN THIS AREA

DO NOT WRITE IN THIS AREA

DO NOT WRITE IN THIS AREA

.....
(Total for Question 18 is 5 marks)



DO NOT WRITE IN THIS AREA

DO NOT WRITE IN THIS AREA

DO NOT WRITE IN THIS AREA

19 Strong winds and heavy rain can independently stop boat trips taking place.

The decision tree diagram shows information about the probabilities that strong winds or that heavy rain will stop the boat trip taking place on any day.

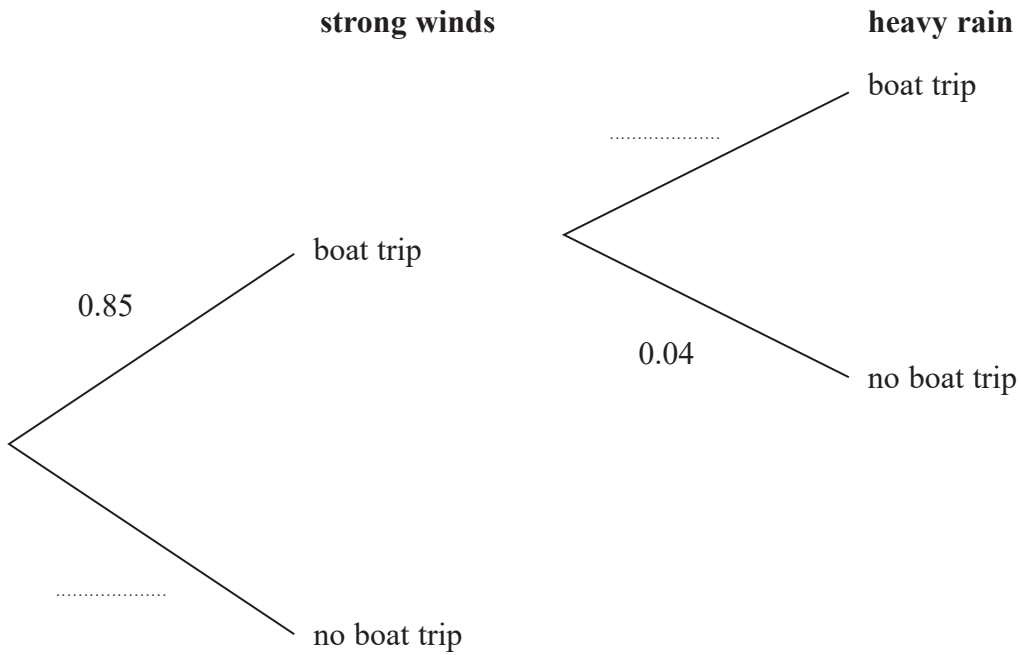

(a) Complete the decision tree diagram.

(1)

A charity plans boat trips on 80 days during the summer.

The charity will make a profit if the boat trips take place on at least 60 days.

*(b) Should the charity expect to make a profit?

(3)

(Total for Question 19 is 4 marks)



*20 The average fuel consumption (c) of a car, in kilometres per litre, is given by the formula

$$c = \frac{d}{f}$$

where d is the distance travelled in kilometres and f is the fuel used in litres.

$d = 180$ correct to 3 significant figures.

$f = 25.4$ correct to 1 decimal place.

By considering bounds, work out the value of c to a suitable degree of accuracy.
You must show **all** of your working **and** give a reason for your final answer.

(Total for Question 20 is 5 marks)

TOTAL FOR PAPER IS 100 MARKS

DO NOT WRITE IN THIS AREA

DO NOT WRITE IN THIS AREA

DO NOT WRITE IN THIS AREA

