

Write your name here

Surname

Other names

Pearson
Edexcel GCSE

Centre Number

--	--	--	--	--

Candidate Number

--	--	--	--

Applications of Mathematics

Unit 2: Applications 2

For Approved Pilot Centres ONLY

Higher Tier

Friday 13 June 2014 – Morning

Time: 1 hour 45 minutes

Paper Reference

5AM2H/01

You must have: Ruler graduated in centimetres and millimetres, protractor, pair of compasses, pen, HB pencil, eraser, calculator. Tracing paper may be used.

Total Marks



Instructions

- Use **black** ink or ball-point pen.
- **Fill in the boxes** at the top of this page with your name, centre number and candidate number.
- Answer **all** questions.
- Answer the questions in the spaces provided – *there may be more space than you need.*
- **Calculators may be used.**
- If your calculator does not have a π button, take the value of π to be 3.142 unless the question instructs otherwise.

Information

- The total mark for this paper is 100
- The marks for **each** question are shown in brackets – *use this as a guide as to how much time to spend on each question.*
- Questions labelled with an **asterisk** (*) are ones where the quality of your written communication will be assessed.

Advice

- Read each question carefully before you start to answer it.
- Keep an eye on the time.
- Try to answer every question.
- Check your answers if you have time at the end.

Turn over ►

P44579A

©2014 Pearson Education Ltd.

5/6/1/



PEARSON

GCSE Mathematics 2AM01

Formulae: Higher Tier

**You must not write on this formulae page.
Anything you write on this formulae page will gain NO credit.**

Volume of prism = area of cross section \times length

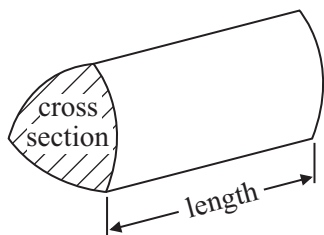

Area of trapezium = $\frac{1}{2} (a + b)h$

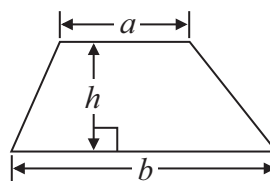

Volume of sphere = $\frac{4}{3} \pi r^3$

Surface area of sphere = $4\pi r^2$

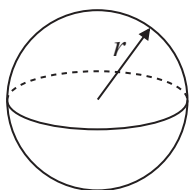

Volume of cone = $\frac{1}{3} \pi r^2 h$

Curved surface area of cone = $\pi r l$

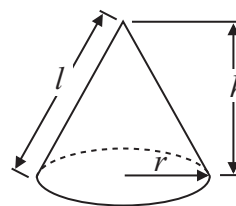

In any triangle ABC

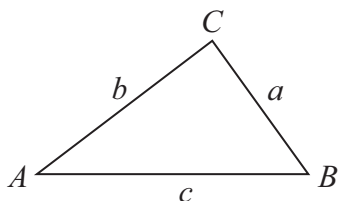

The Quadratic Equation

The solutions of $ax^2 + bx + c = 0$
where $a \neq 0$, are given by

$$x = \frac{-b \pm \sqrt{b^2 - 4ac}}{2a}$$

Sine Rule $\frac{a}{\sin A} = \frac{b}{\sin B} = \frac{c}{\sin C}$

Cosine Rule $a^2 = b^2 + c^2 - 2bc \cos A$

Area of triangle = $\frac{1}{2} ab \sin C$



Answer ALL questions.

Write your answers in the spaces provided.

You must write down all stages in your working.

1 Here is a travel graph of Ryan's cycle journey from his home to the shops.

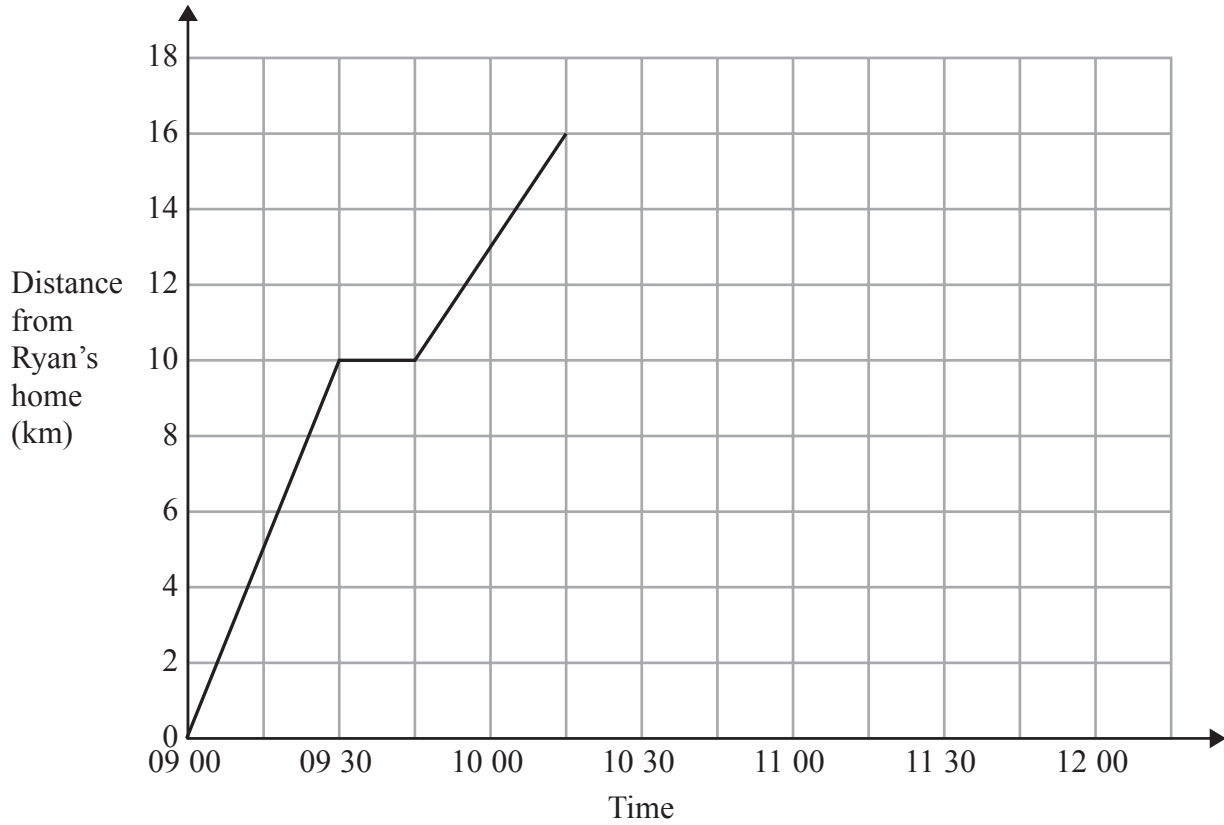

Ryan was at the shops for 30 minutes.
He then cycled back home without stopping.
He got home at 12 00

(a) Complete the travel graph. (2)

(b) What was Ryan's average speed on his way home?
..... kilometres per hour (2)

(Total for Question 1 is 4 marks)



2 Here is an accurate scale drawing of Zena's garden.

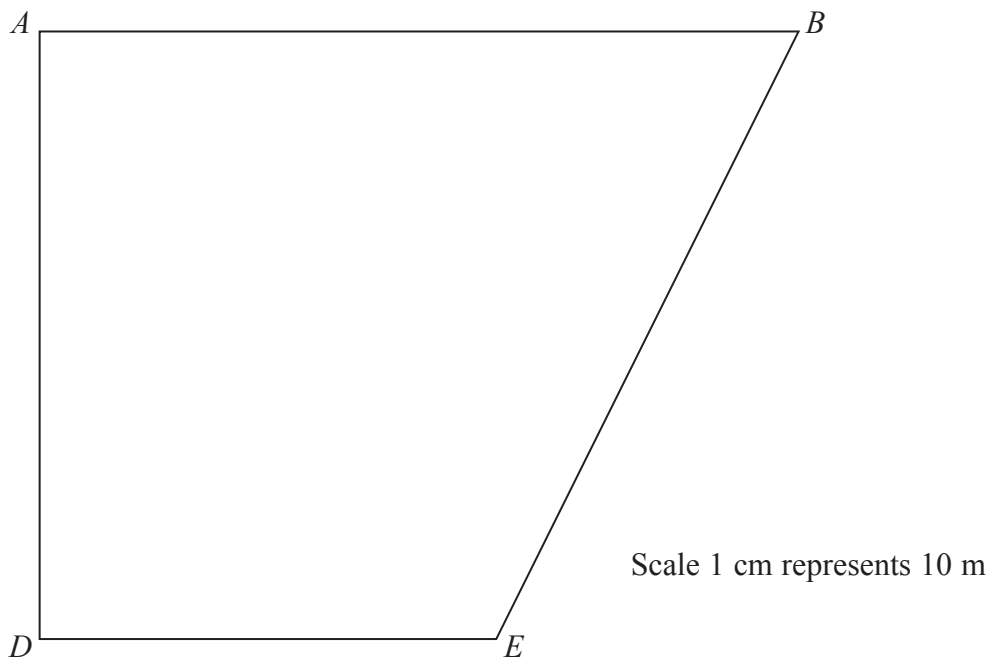

Zena is going to plant a tree in the garden.

She will plant the tree

- nearer to AB than to BE ,
- more than 50 m from AD ,
- and less than 60 m from E .

On the diagram, show accurately by shading, the region where Zena will plant the tree.

(Total for Question 2 is 4 marks)



*3 Mario sells coffee in three different sizes of cup.



Small

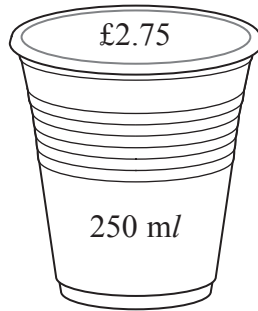

Medium

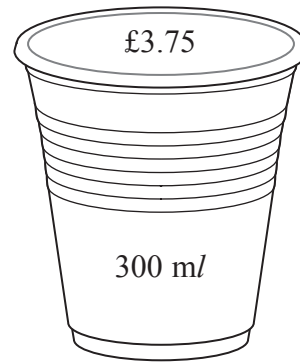

Large

Which size cup of coffee is the best value for money?

(Total for Question 3 is 4 marks)



4 Here is a list of ingredients for making fruit buns.

Fruit buns	
Flour	300 g
Butter	150 g
Sugar	150 g
Mixed fruit	100 g
Eggs	1
Makes 12 fruit buns	

Rosie has

3 kg of flour
900 g of butter
1 kg of sugar
800 g of mixed fruit
12 eggs

What is the greatest number of fruit buns Rosie can make?
You must show your working.

.....
(Total for Question 4 is 4 marks)



*5 Rashmi is 3 years older than Narinder.
Bhavinda is twice as old as Rashmi.

The total of their ages is less than 50

What is Rashmi's greatest possible age?
Give your answer as a whole number of years.

(Total for Question 5 is 4 marks)



6 Gavin does his shopping in Roots supermarket.
He gets 4 points on his Roots store card for every £1 he spends.

Gavin has spent a total of £660 in Roots supermarket.
He wants to use all the points he has got when he buys a pair of sunglasses.

The sunglasses cost £99
Gavin gets 20p off the cost of the sunglasses for every 10 points on his store card.

Gavin buys the sunglasses.
He uses all the points he has got on his store card.
He pays the rest of the cost in money.

How much of the £99 does he pay in money?

£

(Total for Question 6 is 5 marks)



7 An insurance company insured 10 000 small boats last year.
A total of 150 insurance claims were made on these small boats last year.
The company paid an average amount of £1200 on each insurance claim.

The company does **not** want to make a loss when it insures small boats.

What is the least amount of money the company should charge to insure each small boat?

£

(Total for Question 7 is 3 marks)



*8 Susi is going to grow vegetables in a container in her garden.
The container is in the shape of a prism.
The ends of the prism are trapeziums.

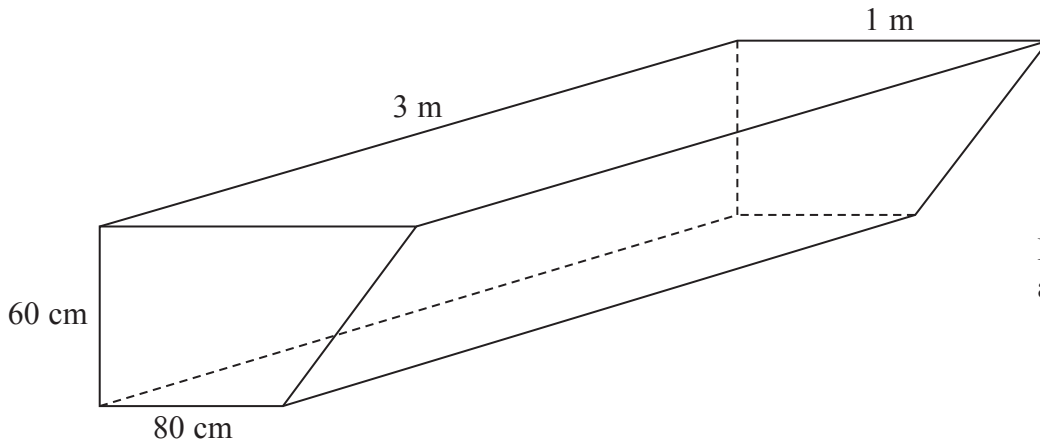

Diagram **NOT**
accurately drawn

Susi plans to fill the container completely with compost to a depth of 60 cm.

Compost is sold in 65 litre bags.

$1 \text{ m}^3 = 1000 \text{ litres}$

How many bags of compost will Susi need to buy?

(Total for Question 8 is 5 marks)



9 There is only one winning ticket in a raffle.

80 raffle tickets are sold.

The winning ticket will be chosen at random.

Helen buys three raffle tickets.

(a) Work out the probability that Helen will **not** win the raffle.

.....
(1)

Jonty also buys some of the raffle tickets.

The probability that Jonty will win the raffle is 0.05

(b) How many raffle tickets does Jonty buy?

.....
(2)

(Total for Question 9 is 3 marks)



10 The aspect ratio of a television is the ratio
width of screen : height of screen

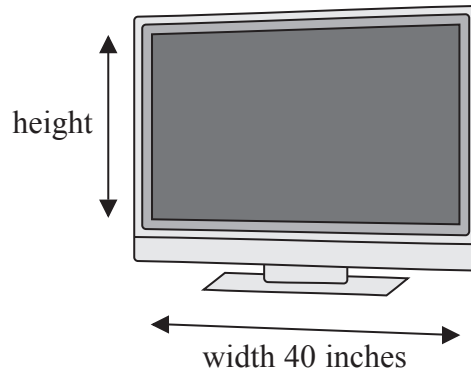

Diagram **NOT**
accurately drawn

Robin buys a television with an aspect ratio of 16 : 9
The screen of the television has a width of 40 inches.

Work out the length of a diagonal of the screen.
Give your answer to the nearest whole number.

..... inches

(Total for Question 10 is 5 marks)



11 Neil uses this conversion graph to change between litres and gallons.

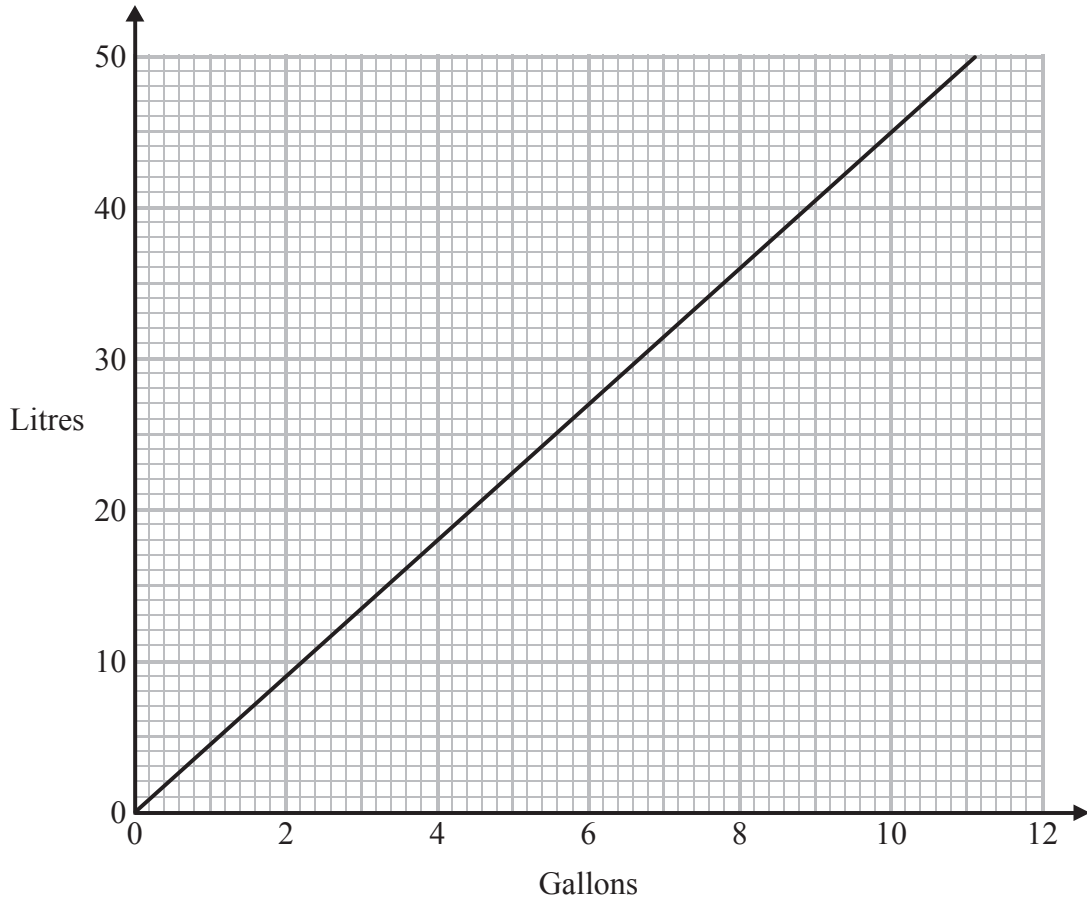

(a) Change 5 gallons to litres.

..... litres
(1)

Neil stores the same type of fuel in two fuel tanks.

There are

- 2000 litres of fuel in tank A
- 800 gallons of fuel in tank B

Neil has to deliver 5000 litres of the fuel to a customer.
He takes all the 2000 litres from tank A and takes some of the fuel from tank B.

(b) How many gallons of fuel are left in tank B?

..... gallons
(4)

(Total for Question 11 is 5 marks)



12 This graph shows the depth of water in a harbour between 00 00 and 18 00 one day.

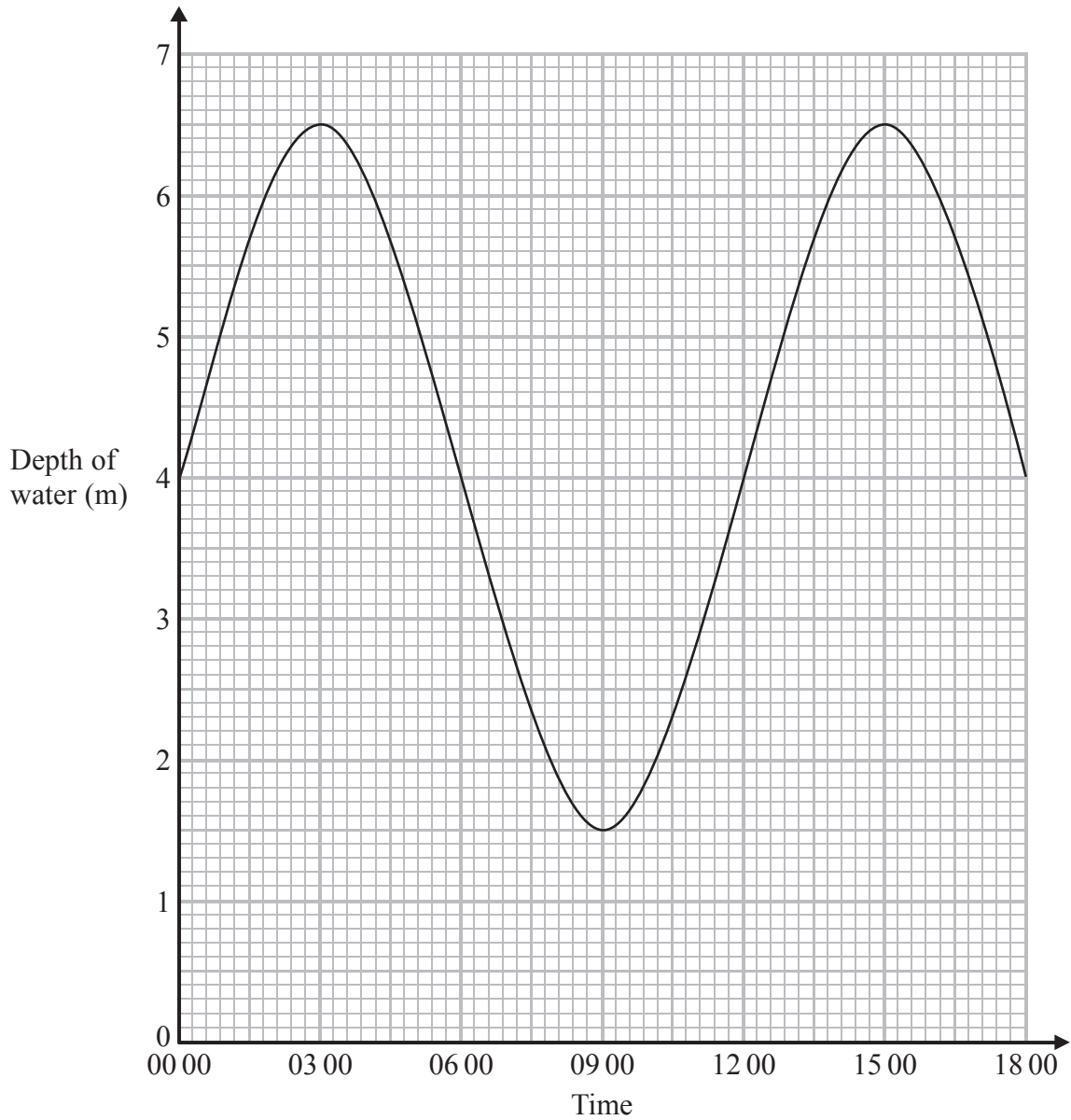

(a) What is the depth of water at 09 00?

..... m
(1)

(b) At what times is the depth of water 3 m?

.....
(2)

(c) How long was the depth of water 5 m or less between 03 00 and 15 00?

.....
(1)

(Total for Question 12 is 4 marks)



13 Ben, Gerri and Lisa go to a fish and chip shop.

Gerri buys 4 portions of chips.
It costs her £3.60

Ben buys 3 portions of chips and 4 fish.
It costs him £9.90

(a) Work out the cost of one fish.

£
(4)

Lisa gets a discount.
She gets $\frac{1}{5}$ off her bill.
She pays £10.80

(b) Work out the amount of her bill before the discount.

£
(3)

(Total for Question 13 is 7 marks)



14 The diagram shows a TV mast on horizontal ground.

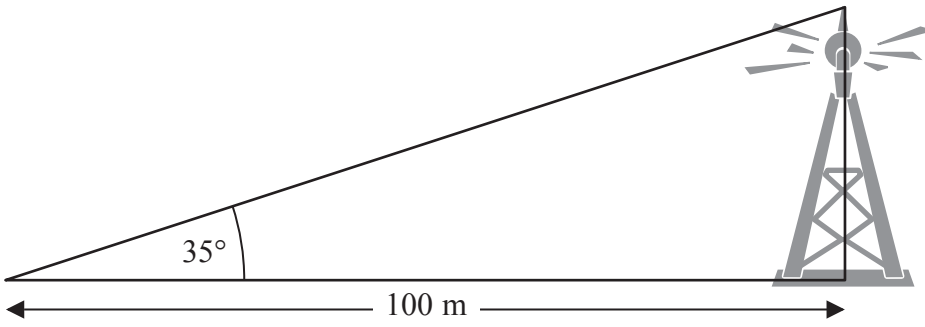

Diagram **NOT** accurately drawn

Rhianna measures the angle of elevation of the top of the TV mast. She is 100 m from the TV mast.

(a) Work out the height of the TV mast.

..... m
(3)

The diagram shows a ramp.

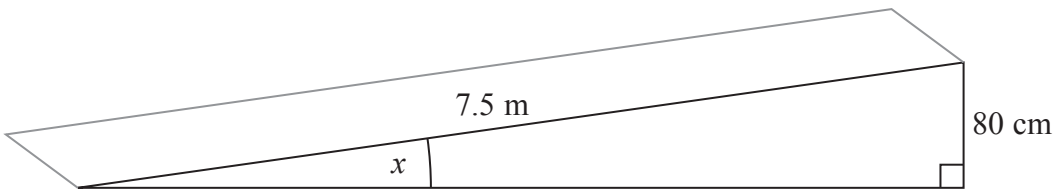

Diagram **NOT** accurately drawn

Rhianna has to find the size of the angle marked x .

(b) Work out the size of the angle marked x .

..... °
(3)

(Total for Question 14 is 6 marks)



15 Hot drinks are served at a temperature of 70 °C.

The graph shows the temperature of a hot drink as it cools in a china mug from the time it is served.

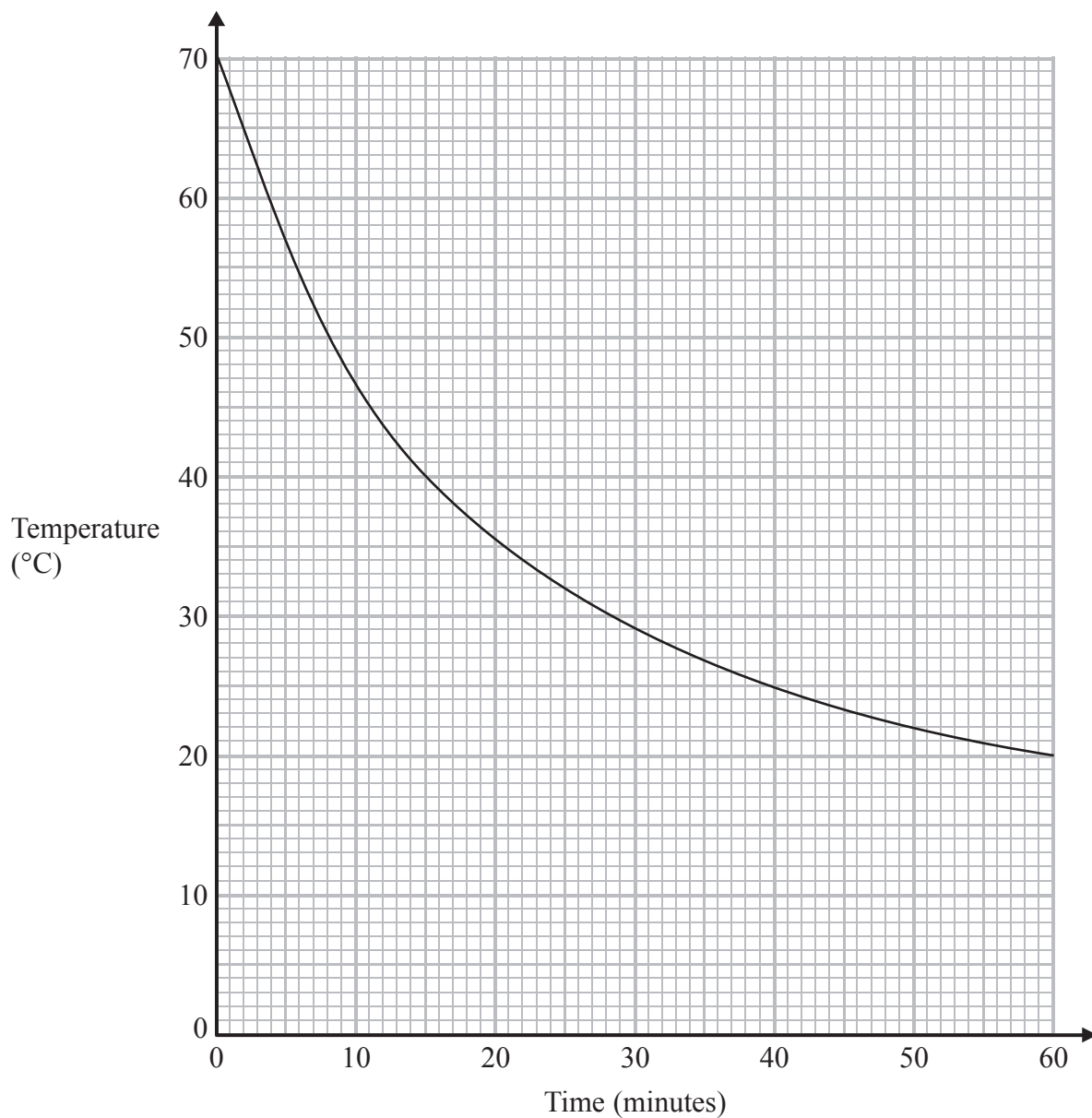

Work out the rate of cooling of the drink at time 20 minutes.

..... °C per minute

(Total for Question 15 is 3 marks)



16 Here is the diagram of a cold frame.
 The frame is in the shape of a right-angled triangular prism.

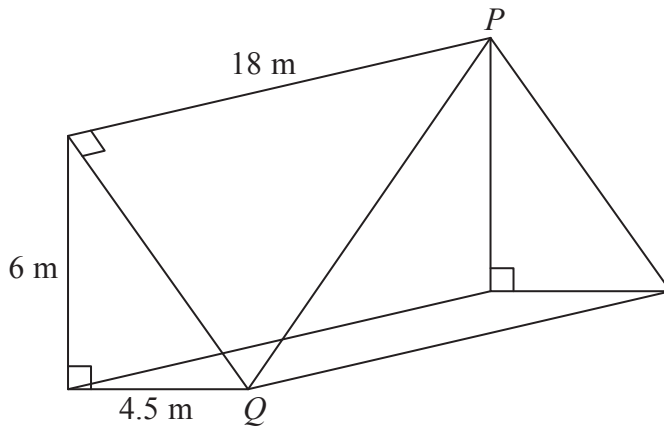

Diagram **NOT** accurately drawn

A straight rod joins P to Q .

Work out the length of the rod.

..... m

(Total for Question 16 is 4 marks)



- 17 Oil is stored in a tank at an oil refinery.
The tank is in the shape of a cylinder.

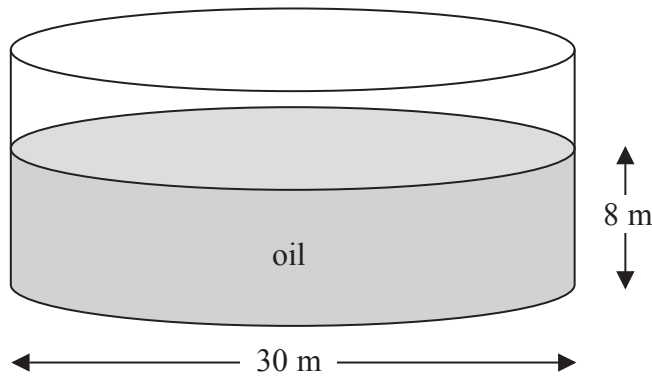

Diagram **NOT**
accurately drawn

The tank has a diameter of 30 m.
The depth of the oil in the tank is 8 m.

The density of the oil is 800 kg per m^3 .
An oil tanker can hold up to 50 000 kg of oil.

How many of these oil tankers are needed to empty all the oil from the tank?
You must show all your working.

(Total for Question 17 is 5 marks)



*18 The average fuel consumption (c) of a car, in kilometres per litre, is given by the formula

$$c = \frac{d}{f}$$

where d is the distance travelled in kilometres and f is the fuel used in litres.

$d = 190$ correct to 3 significant figures.

$f = 25.7$ correct to 1 decimal place.

By considering bounds, work out the value of c to a suitable degree of accuracy.
You must show **all** of your working **and** give a reason for your final answer.

(Total for Question 18 is 5 marks)



19 Mr Jones marks out the sports field for a discus competition.

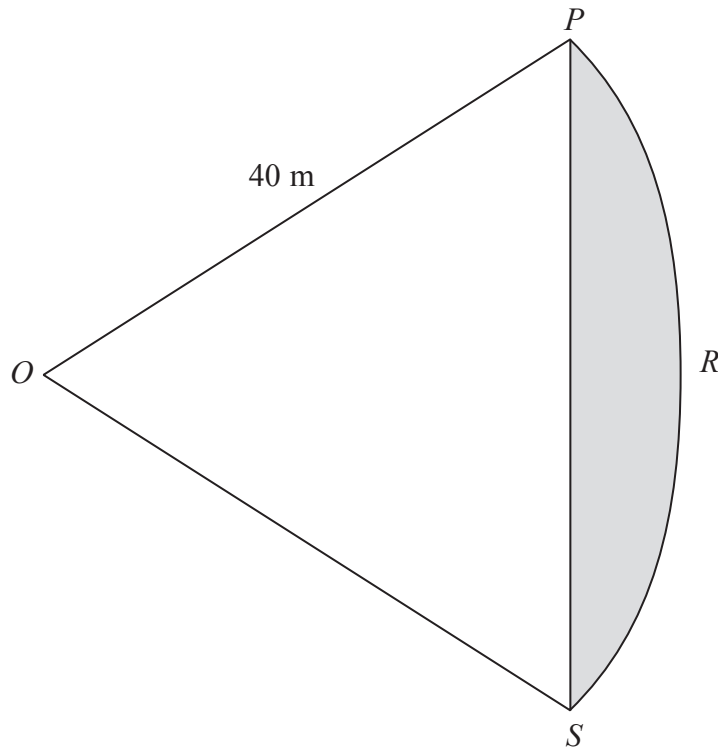

Diagram **NOT**
accurately drawn

PRS is an arc of a circle centre O with radius 40 m .

PS is a chord of the circle.

OPS is an equilateral triangle.

Calculate the area of the shaded segment.

Give your answer correct to 3 significant figures.

..... m^2

(Total for Question 19 is 5 marks)



- 20 A car accelerates from 0 metres per second to 60 metres per second in 20 seconds. It then travels at a constant speed of 60 metres per second for 30 seconds.

The speed-time graph shows this information.

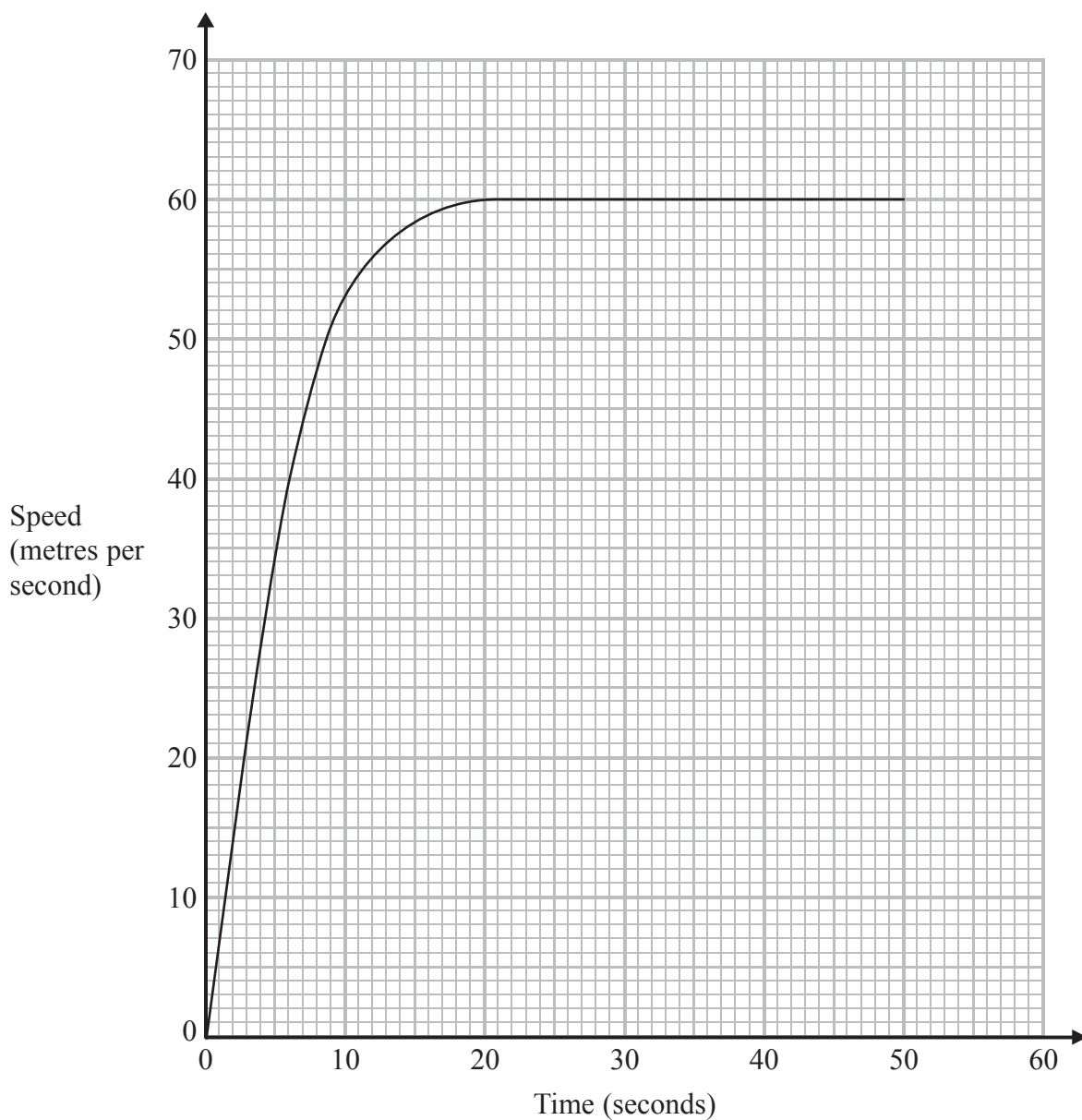

Work out an estimate for the distance the car travelled in these 50 seconds.

..... km

(Total for Question 20 is 3 marks)



21 Rhodri is investigating the population growth of the rabbits in an enclosure.

He counted the number of rabbits at the start of month 0

He counted the number of rabbits at the start of month 2

Here are his results.

Month	Population
0	100
2	200

The population of rabbits is increasing exponentially.

How many rabbits will there be at the start of month 5?

You must show your working.

..... rabbits

(Total for Question 21 is 5 marks)



***22** Polly insures pets.
 50% of the pets insured are dogs.
 30% of the pets insured are cats.

The probability tree diagram shows information about the probability of insurance claims being made on these pets.

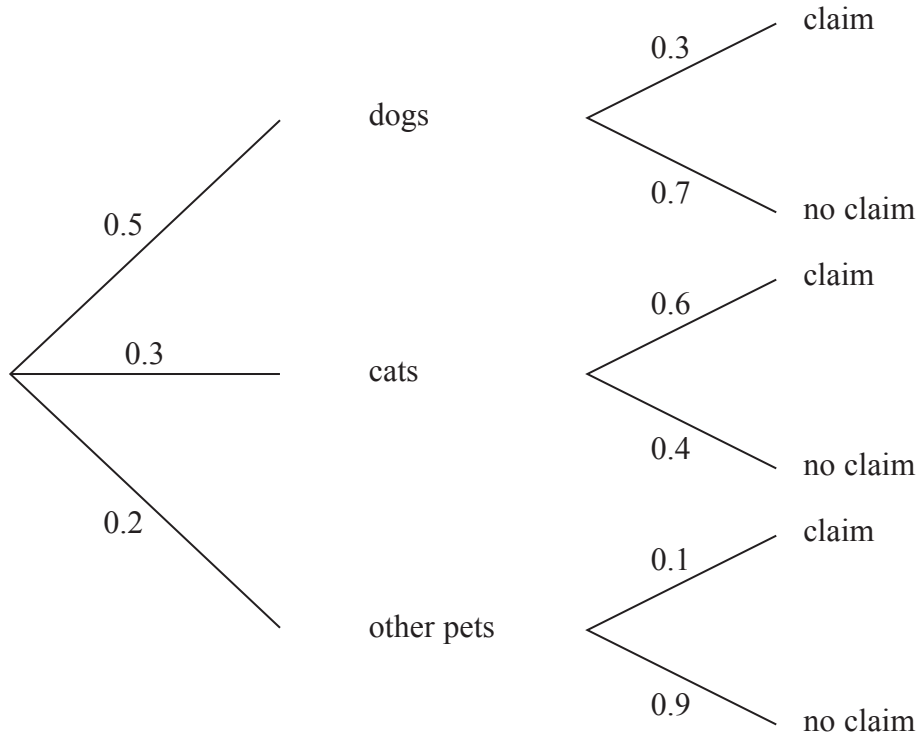

The table shows the average cost of each claim for each type of pet.

Dog	£360
Cat	£310
Other pets	£160

Compare the risk to Polly for each type of pet.

(Total for Question 22 is 3 marks)



- 23 Farouk makes models by pouring resin into moulds.
The models are mathematically similar.



small



medium



large

The height of the small model is 10 cm.
The height of the medium model is 15 cm.
The height of the large model is 25 cm.

Farouk uses 250 g of resin to make the small model.

- (a) How much resin does he use to make the medium model?

..... g
(2)

Farouk uses 90 ml of paint to paint the large model.

- (b) How much paint does he use to paint the small model?

..... ml
(2)

(Total for Question 23 is 4 marks)

TOTAL FOR PAPER IS 100 MARKS



BLANK PAGE



BLANK PAGE



BLANK PAGE

