

Write your name here

Surname

Other names

**Pearson**  
**Edexcel GCSE**

Centre Number

--	--	--	--	--

Candidate Number

--	--	--	--

# Applications of Mathematics

## Unit 1: Applications 1

*For Approved Pilot Centres ONLY*

**Foundation Tier**

Monday 9 June 2014 – Morning

**Time: 1 hour 45 minutes**

Paper Reference

**5AM1F/01**

**You must have:** Ruler graduated in centimetres and millimetres, protractor, pair of compasses, pen, HB pencil, eraser, calculator. Tracing paper may be used.

Total Marks



### Instructions

- Use **black** ink or ball-point pen.
- **Fill in the boxes** at the top of this page with your name, centre number and candidate number.
- Answer **all** questions.
- Answer the questions in the spaces provided – *there may be more space than you need.*
- **Calculators may be used.**
- If your calculator does not have a  $\pi$  button, take the value of  $\pi$  to be 3.142 unless the question instructs otherwise.

### Information

- The total mark for this paper is 100
- The marks for **each** question are shown in brackets – *use this as a guide as to how much time to spend on each question.*
- Questions labelled with an **asterisk** (\*) are ones where the quality of your written communication will be assessed.

### Advice

- Read each question carefully before you start to answer it.
- Keep an eye on the time.
- Try to answer every question.
- Check your answers if you have time at the end.

Turn over ►

P43387A

©2014 Pearson Education Ltd.

5/6/1/1/c2/



**PEARSON**

GCSE Mathematics 2AM01

Formulae: Foundation Tier

**You must not write on this formulae page.  
Anything you write on this formulae page will gain NO credit.**

**Area of trapezium** =  $\frac{1}{2}(a + b)h$

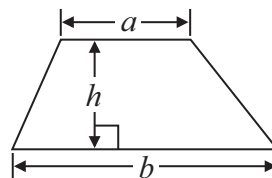

**Volume of prism** = area of cross section  $\times$  length

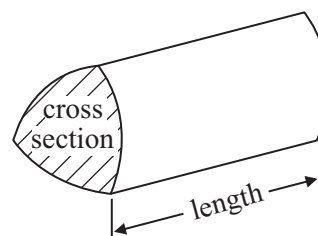

**Answer ALL questions.**

**Write your answers in the spaces provided.**

**You must write down all stages in your working.**

**1** Karim does the accounts for his cricket team.

Here are his accounts for part of May.

<b>Date</b>	<b>Description</b>	<b>Deposit (£)</b>	<b>Withdrawal (£)</b>	<b>Balance (£)</b>
1st May	Opening balance			50.00
2nd May	Match fees	66.00		116.00
8th May	New bat		30.00	86.00
15th May	Refreshments		10.00	76.00
23rd May	Match Fees	66.00		.....
.....	.....		.....	.....

On 25th May he makes a withdrawal of £51.50 for pitch hire.

(a) Write this information in Karim's accounts.

(2)

(b) Complete the balance column.

(2)

**(Total for Question 1 is 4 marks)**



2 Jim wants to park his car in the car park.  
He will have to pay 110p.

Jim has only these coins.

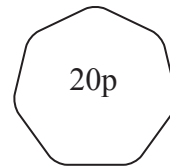
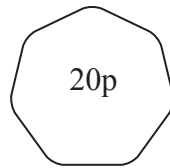
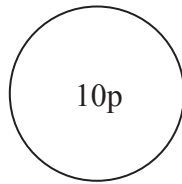
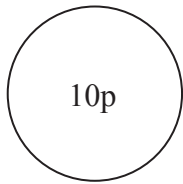
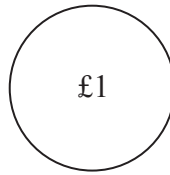
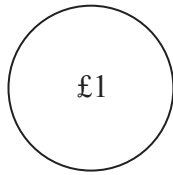
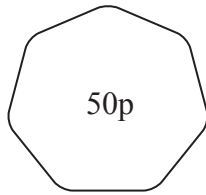

Jim wants to use as few of his coins as possible to pay 110p.

Show how he can do this.

.....  
**(Total for Question 2 is 2 marks)**



3 There are 4 year 11 classes in a school.

The bar chart gives information about the numbers of students in these 4 classes.

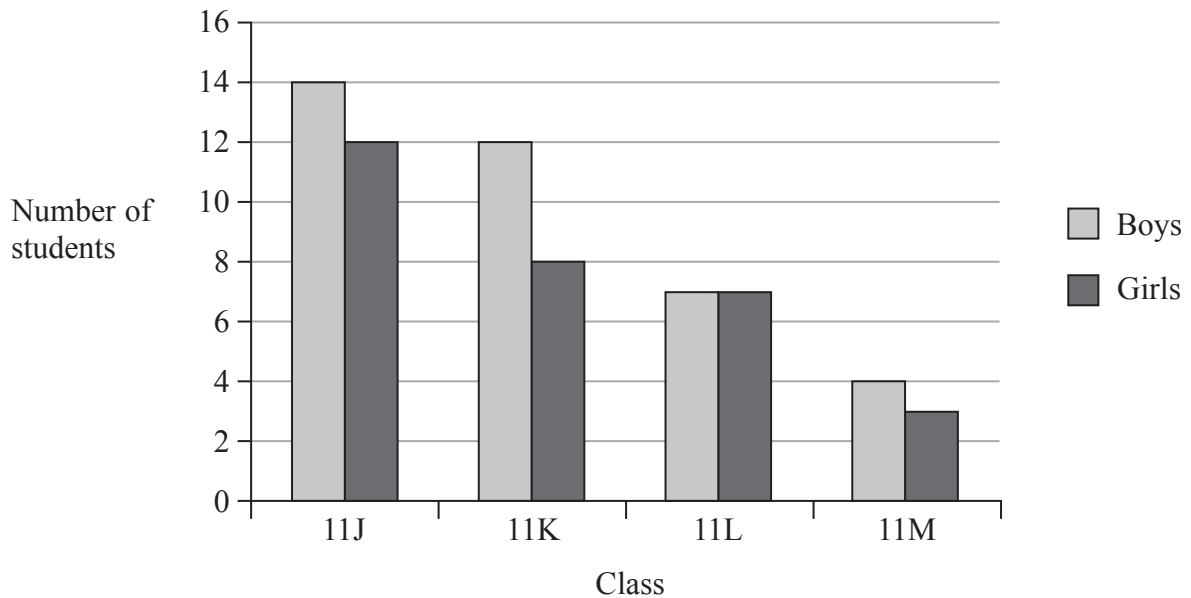

(a) Write down the number of boys in class 11J.

.....  
(1)

(b) Write down the class that has equal numbers of boys and girls.

.....  
(1)

(c) Work out the total number of students in year 11

.....  
(2)

**(Total for Question 3 is 4 marks)**



4 Keith is going to catch a plane.

He weighs his bag on some scales.

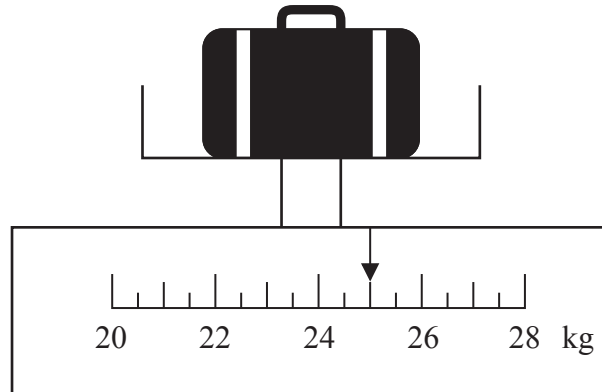

(a) Write down the weight shown on the scales.

..... kg  
(1)

There is an extra charge to pay when the weight of a bag is more than 23 kg.

The weight of Grant's bag is 19.5 kg.

He does **not** want to pay the extra charge.

(b) How much more weight can he put in the bag?

..... kg  
(1)

Nina has two bags.

The weight of each bag is 20 kg.

1 kg = 2.2 pounds.

(c) What is the total weight of Nina's bags in pounds?

..... pounds  
(3)

**(Total for Question 4 is 5 marks)**



5 Here is the logo for 'Diamond Designs'.

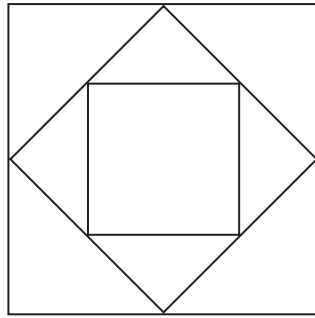

There are squares in the logo.

(a) Write down the size of an angle of a square.

.....  
(1)

(b) Write down the order of rotational symmetry of the logo.

.....  
(1)

(c) Find two shapes in the logo that are congruent.

Put a letter C in each of the two shapes.

(1)

**(Total for Question 5 is 3 marks)**



- 6 Here is a plan of the site of a Roman villa.  
The site has been marked out in squares.

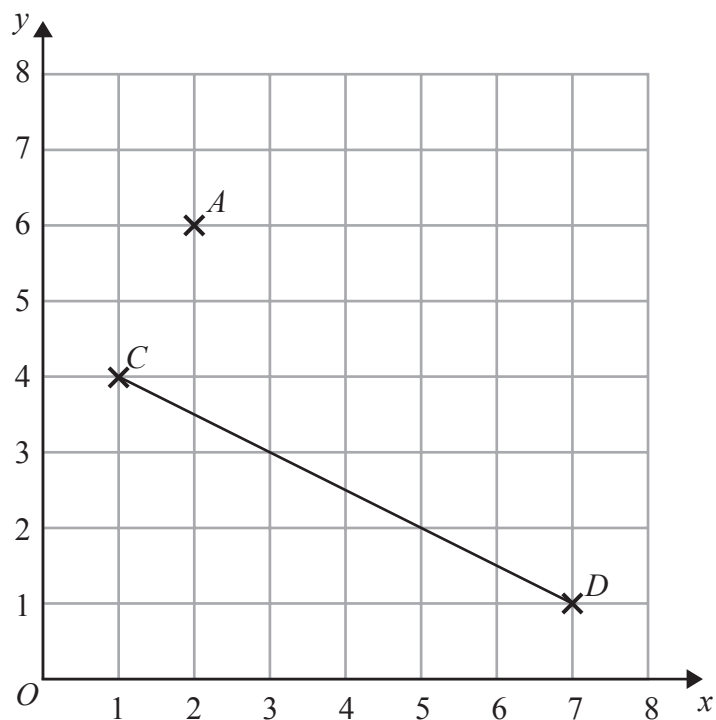

There is an iron pot at  $A$ .

- (a) Write down the coordinates of the point  $A$ .

.....  
(1)

There is a gold coin at the point with coordinates  $(5, 7)$ .

- (b) On the grid, mark with a cross ( $\times$ ) the position of the gold coin.  
Label this point  $G$ .

(1)

A pipe goes from the point  $C$  to the point  $D$ .

The midpoint of  $CD$  is  $M$ .

Mick wants to mark  $M$  with white tape.

- (c) Find the coordinates of  $M$ .

.....  
(2)

(Total for Question 6 is 4 marks)





7

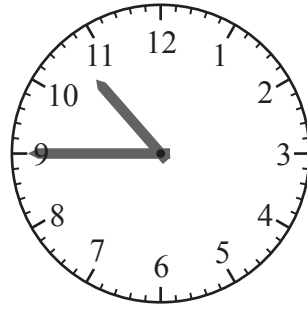

(a) What time is shown on this clock?

.....  
(1)

(b) Write 7 20 pm using the 24-hour clock.

.....  
(1)

Lessons end at Ashley's school at 3 45 pm.  
A dance club starts 15 minutes after the end of lessons.

The dance club lasts  $\frac{3}{4}$  of an hour.

Ashley goes to the dance club.  
It then takes him 25 minutes to get home.

(c) Work out the time that Ashley gets home.

..... pm  
(3)

**(Total for Question 7 is 5 marks)**



8 The table gives information about some televisions.

Make	Size (inches)	Smart TV	Built in DVD player	Cost (£)
Blunt	24	–	–	199
Blunt	40	–	–	342
Lichee	40	Yes	Yes	614
Para	26	Yes	–	248
Para	22	–	Yes	130
Para	50	–	–	480
Sonia	47	–	–	1170

(a) Write down the size of the smallest television.

..... inches  
(1)

(b) Write down the make of the television that has Smart TV and a built in DVD player.

.....  
(1)

The Smiths want to buy a new television.

The cost must be less than £700

The size must be greater than 40 inches.

(c) Write down the cost of the television the Smiths can buy.

£.....  
(1)

**(Total for Question 8 is 3 marks)**



\*9 Alice makes enamel letters to sell.

Liz wants to buy the enamel letters that spell her name.

Here are the three letters drawn on a grid of centimetre squares.

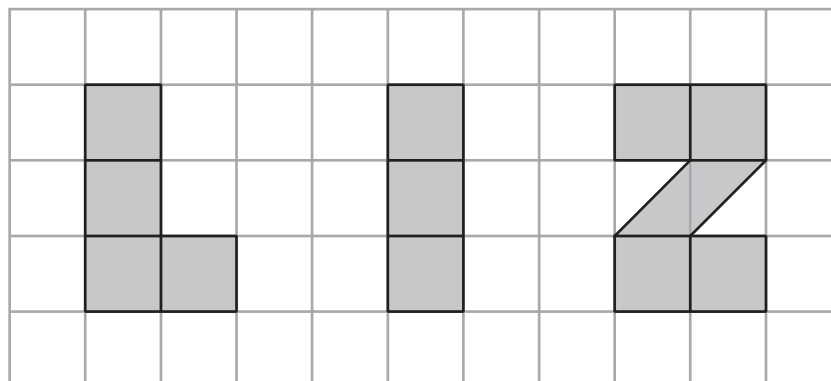

Alice offers two deals for paying for letters.

Deal 1 – pay £5 for each square centimetre of each letter.

Deal 2 – pay £10, then pay £3.50 for each square centimetre of each letter.

Liz wants to pay the least amount of money.

Which deal should she choose?

You must show how you got your answer.

(Total for Question 9 is 5 marks)



10 Here is a diagram of part of a toy for sorting shapes.

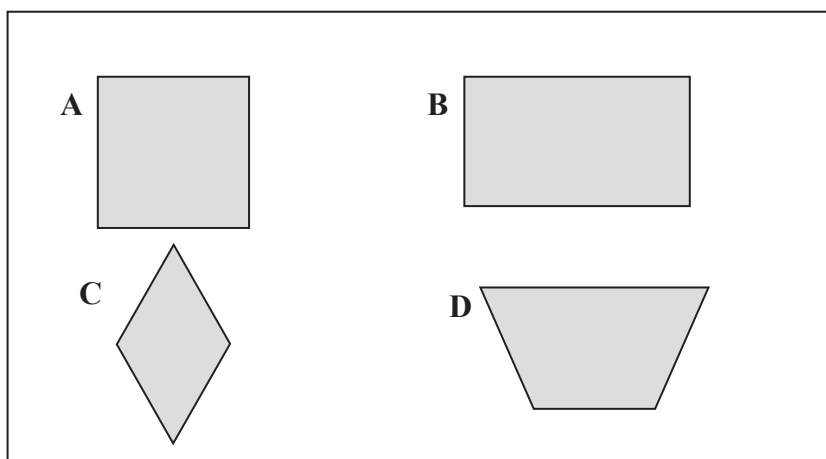

Here are the names of some quadrilaterals.

trapezium    square    parallelogram    rhombus    kite    rectangle

Write the name of the correct quadrilateral next to the letter of the shape.

A.....

B.....

C.....

D.....

(Total for Question 10 is 2 marks)



\*11 Araminta works as a sales representative for a company.

She has to drive to shops to show the products the company makes.

The table gives information about how far she drives each day one week on company business.

	<b>Monday</b>	<b>Tuesday</b>	<b>Wednesday</b>	<b>Thursday</b>	<b>Friday</b>
<b>Miles</b>	38	86	0	45	120

The company pays Araminta these expenses for each day she drives on company business.

40p for each mile

£7.50 for lunch on each day she drives

The company pays Araminta expenses of £150 for that week.

Has the company paid her enough money?

You must show how you got your answer.

**(Total for Question 11 is 5 marks)**



P 4 3 3 8 7 A 0 1 3 3 2

12 Robin is going to make a nest box for birds in his garden.

Here is a sketch of the front of the nest box.



nest box

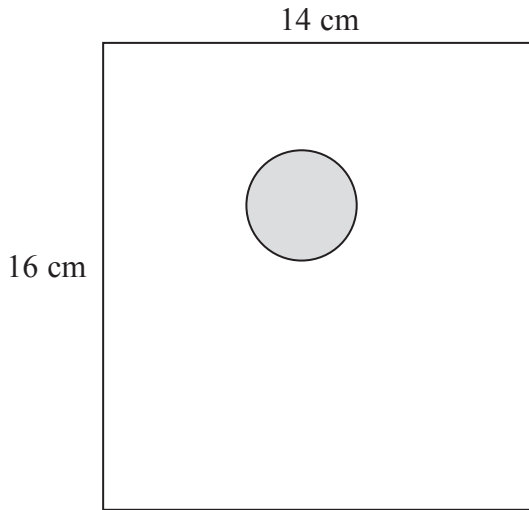

Diagram **NOT** accurately drawn

The front of the nest box is a piece of wood in the shape of a rectangle with a circular hole in it.

An accurate full size drawing of the rectangle is shown on the page opposite.

The diameter of the circular hole is 4 cm.

$P$  is the centre of the circular hole.

$M$  is the midpoint of the top edge of the piece of wood.

(a) Measure the distance  $PM$ .

..... cm

(1)

(b) On the diagram opposite, draw a circle centre  $P$  with a diameter of 4 cm.

(2)



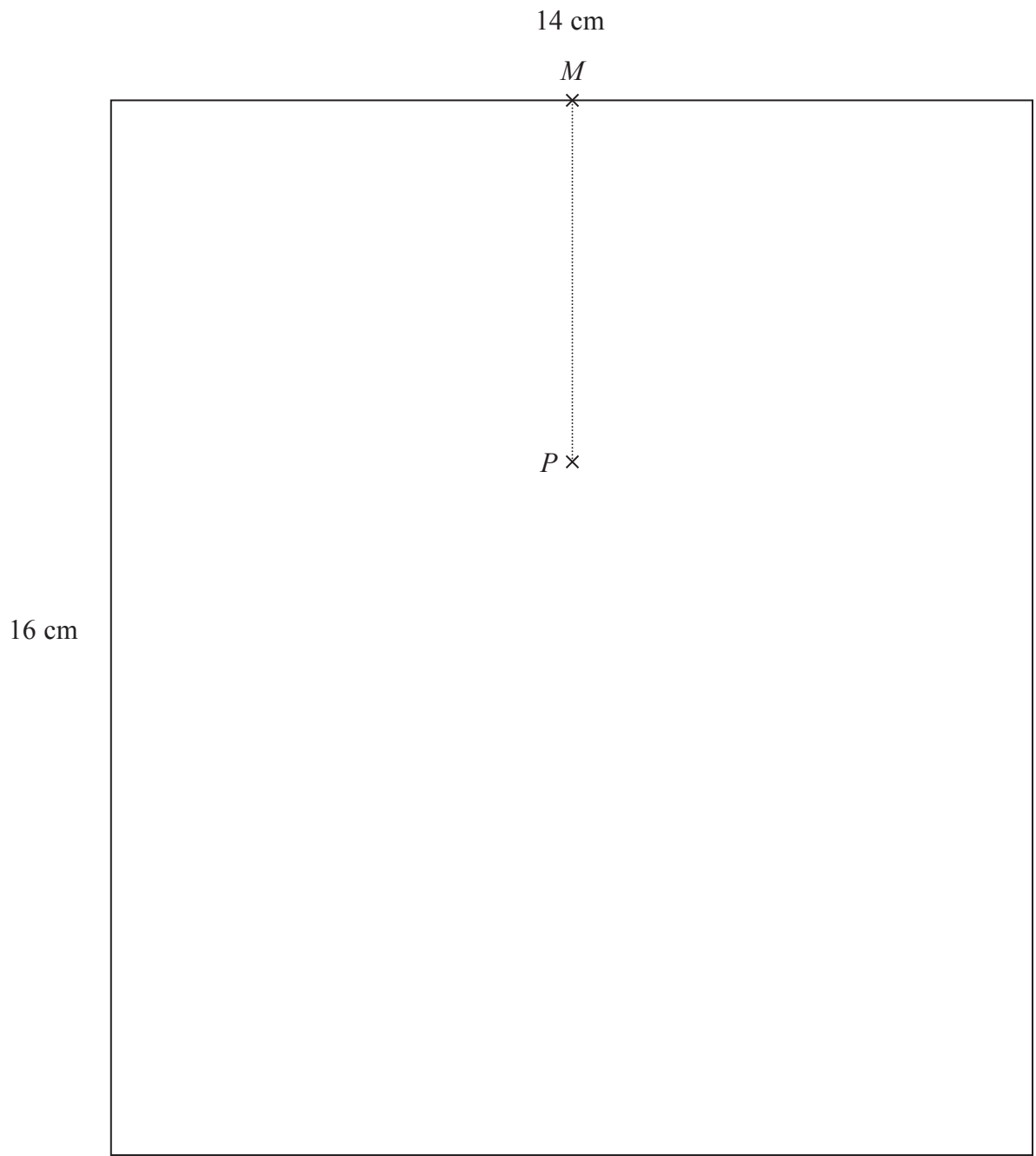

(Total for Question 12 is 3 marks)



13 Cassie is making shapes out of paper.

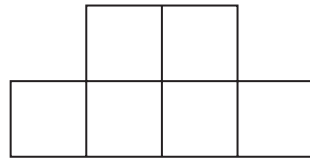

She folds this paper shape through  $180^\circ$  along its line of symmetry.

(a) Put a circle around the letter of the shape she could make.

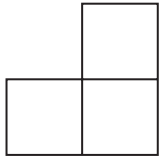

**A**



**B**

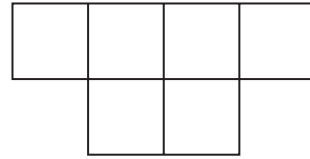

**C**



**D**

(1)

Cassie also has this shape made of paper.

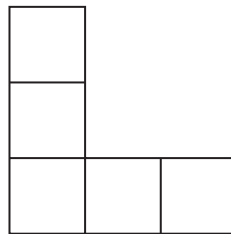

She folds this paper shape through  $180^\circ$  along its line of symmetry.

(b) Draw the shape that she could make.

(2)

(Total for Question 13 is 3 marks)





14 The full price of a ticket for a football match is £24

Disabled people pay 50% of the full price.

(a) Work out 50% of £24

£ .....  
(1)

There were 8768 people at the football match.

(b) Write 8768 correct to the nearest 100

.....  
(1)

750 people at the match were senior citizens.

There were 3 times as many children at the match as senior citizens.

(c) Work out how many of the 8768 people were **not** children or senior citizens.

.....  
(3)

(Total for Question 14 is 5 marks)



15 Here is a diagram of Gareth's lawn.

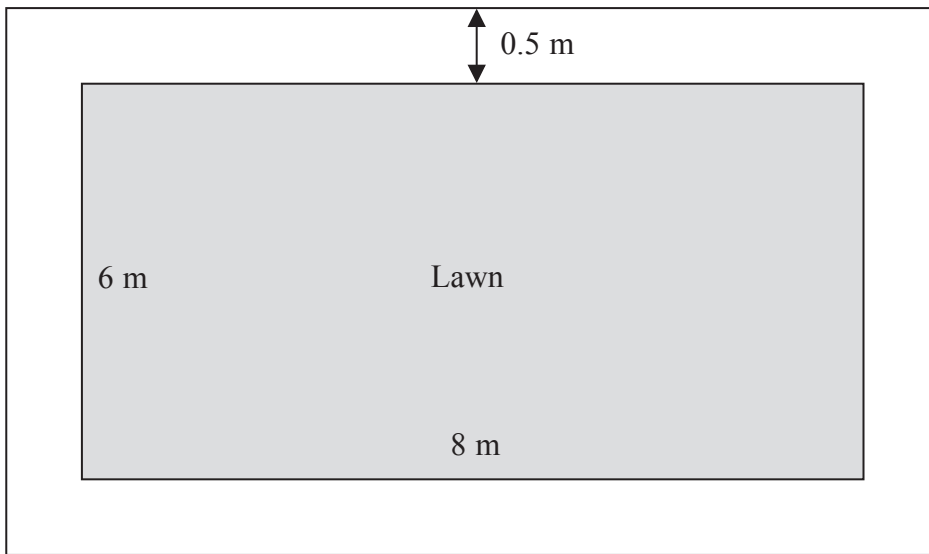

Diagram **NOT** accurately drawn

The lawn is in the shape of a rectangle.  
The length of the lawn is 8 m.  
The width of the lawn is 6 m.

There is a path all the way around the lawn.  
The path is made from paving slabs.  
Each paving slab is a square 0.5 m by 0.5 m.  
The width of the path is 0.5 m.

Work out the number of paving slabs in the path.

(Total for Question 15 is 3 marks)



16 Ben programs his computer to make music.

He programs his computer

to 'beep' every 2 seconds,  
to 'thud' every 3 seconds.

The music lasts for 20 seconds.

At the start of the music a 'beep' and a 'thud' sound together.

(a) After how many seconds will a 'beep' and a 'thud' next sound together?

..... seconds  
(1)

(b) How many times will there be a 'beep' in the 20 seconds?

.....  
(1)

(c) After how many seconds will a 'beep' and a 'thud' sound together for the last time in the 20 seconds?

..... seconds  
(2)

**(Total for Question 16 is 4 marks)**



17 Salma sells dresses online.

She gives a discount for dresses with a price of more than £80  
She charges £6.40 for postage.

Salma uses this flow chart to work out the total charge to customers.

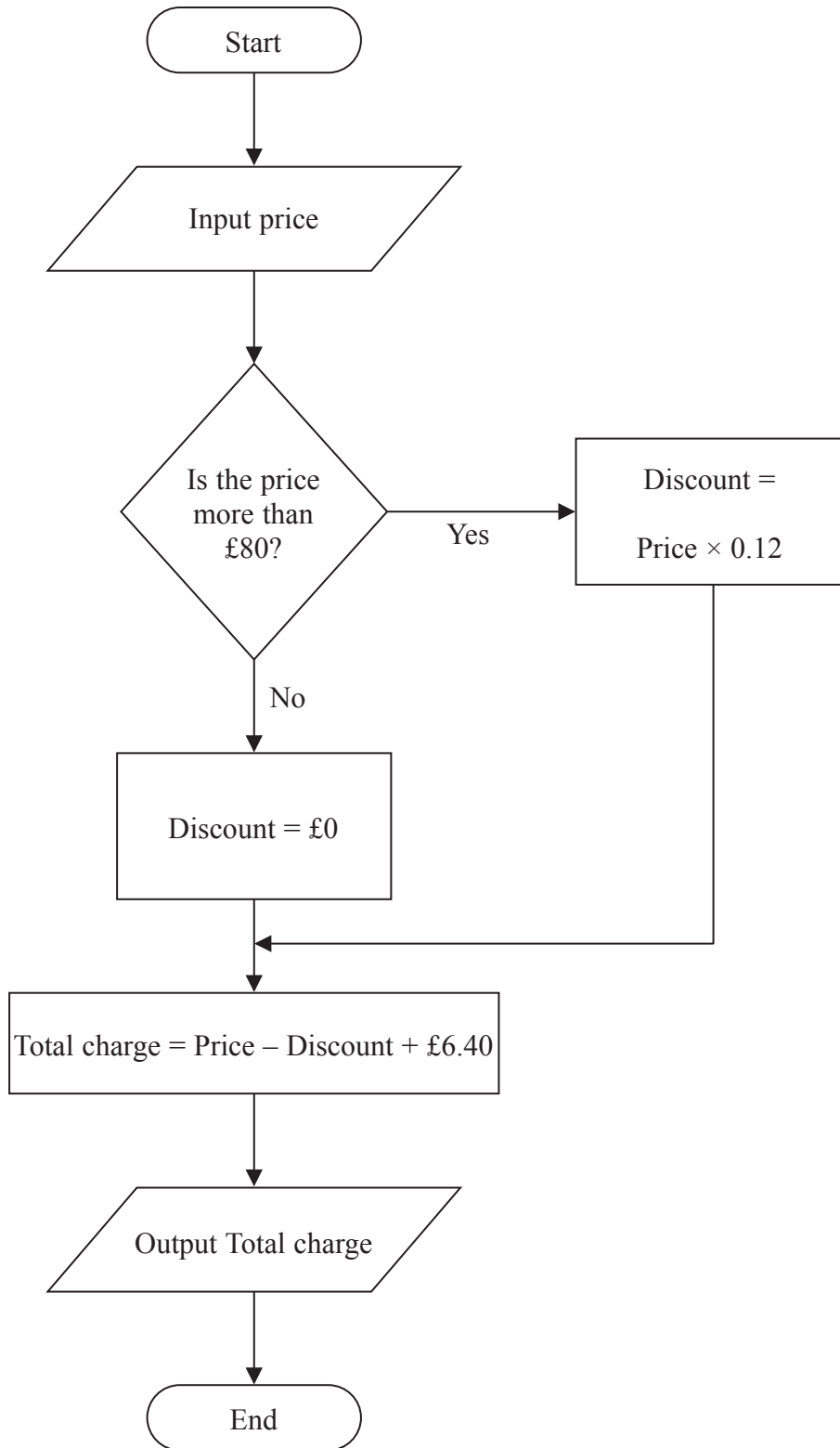

The price of a dress is £100

(a) Work out how much Salma will charge for the dress.

£ .....  
(2)

Soo Min paid £45.60

(b) What was the price of the dress?

£ .....  
(1)

Salma is going to change how she works out the total charge.

She is going to give a discount when the price of a dress is more than £70

(c) In the space below, show the part of the flow chart she needs to change **and** show the change she needs to make.

(2)

(Total for Question 17 is 5 marks)



**18** The cost of living index has increased by 30% from the year 2004 to the year 2014

In 2004, Shola's wage was £340 a week.

In 2014, his wage was £450 a week.

Show that Shola's wage has increased by more than the increase in the cost of living index.

---

**(Total for Question 18 is 3 marks)**



19 The pie chart gives information about the running costs of a water company for one year.

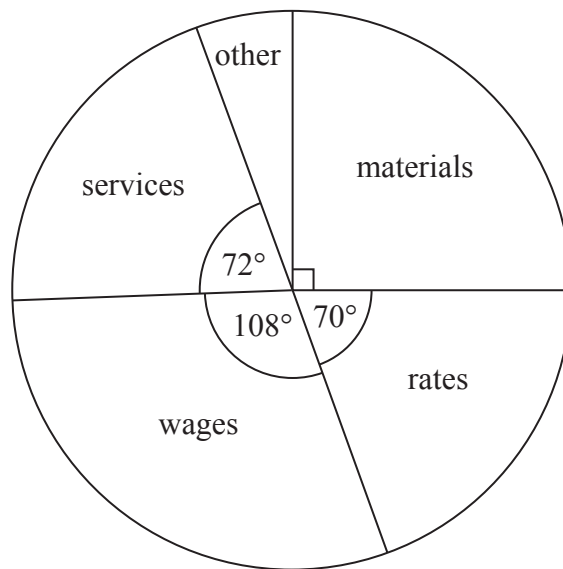

(a) What did the water company spend most on?

.....  
(1)

(b) What fraction of the total running costs did the water company spend on services?  
Give your answer in its simplest form.

.....  
(2)

The water company spent £18 million on materials.

(c) Work out the total amount it spent on running costs.

£ ..... million  
(2)

**(Total for Question 19 is 5 marks)**



**20** Scotland has an area of 30 000 square miles.

$\frac{1}{6}$  of the area is woodland.

$\frac{3}{4}$  of the area of woodland is covered with pine trees.

Work out the area of woodland covered with pine trees.

.....square miles

**(Total for Question 20 is 3 marks)**

---





**21** Tyler has £ $x$

Kayla has twice as much money as Tyler.

Lauren has £4 more than Kayla.

- (a) Write an expression, in terms of  $x$ , for the total amount of money they have in pounds.  
Give your answer in its simplest form.

.....  
(2)

Kayla has £12

- (b) Work out the total amount of money they have.

£.....  
(3)

**(Total for Question 21 is 5 marks)**

---



22 The table gives information about 177 men in a town.

It shows their ages when they first got married.

Age (years)	Frequency
Under 20	0
20 – 24	19
25 – 29	60
30 – 34	52
35 – 39	27
40 – 44	12
45 – 49	5
50 – 54	2
Over 54	0

(a) Draw a frequency polygon to show this information.

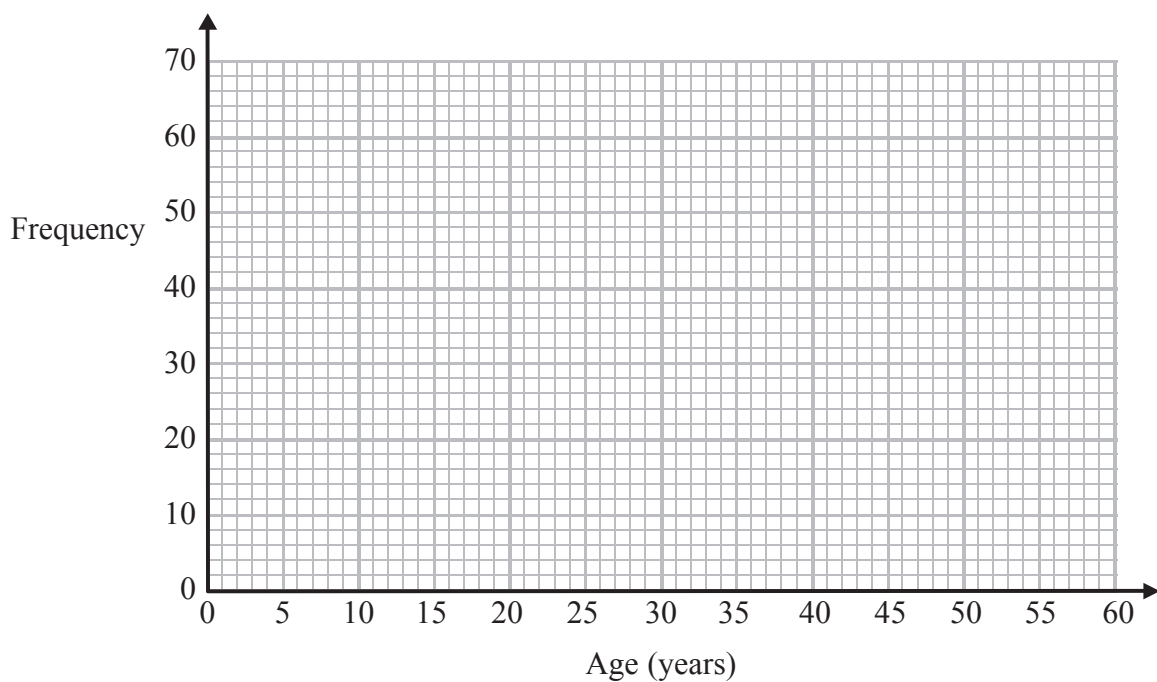

(2)

(b) Find the class interval that contains the median.

.....  
(1)



The table gives information about the ages of people in the town when they first got married.

	Years		Years
Age of youngest woman	18	Age of youngest man	20
Age of oldest woman	54	Age of oldest man	52

The median of the ages of the women when they first got married was 28.5 years.

\*(c) Compare the distribution of the ages of the women when they first got married and the distribution of the ages of the men when they first got married.

.....

.....

.....

.....

(2)

**(Total for Question 22 is 5 marks)**



23 A company sells two types of candles, standard candles and super candles.

The scatter graph gives information about the lifetime (hours) of some standard candles of different heights (cm).

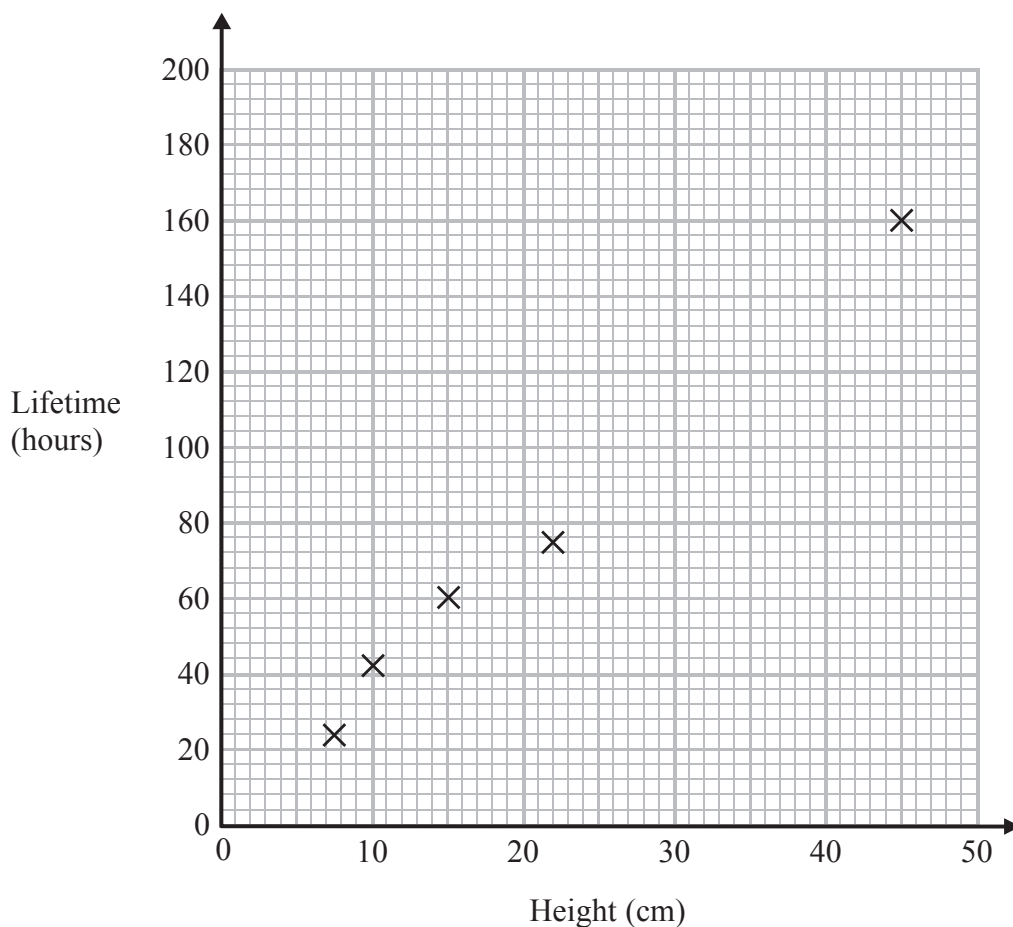

Sam burns a standard candle with a height of 30 cm. It has a lifetime of 115 hours.

(a) Show this information on the scatter diagram. (1)

(b) Draw a line of best fit on the diagram. (1)

A standard candle has a height of 35 cm.

(c) Find an estimate for the lifetime of this candle.

..... hours  
(1)



The lifetime of a super candle is 4 times the lifetime of a standard candle of the same height.

The lifetime of one of these super candles is 200 hours.

(d) Find an estimate for the height of this super candle.

..... cm

(2)

**(Total for Question 23 is 5 marks)**

---



P 4 3 3 8 7 A 0 2 9 3 2

24 Nimer sells security equipment to schools.

He is paid a basic wage.

He is also paid commission on his sales.

Nimer's boss uses this equation to work out Nimer's total pay.

$$y = 0.3x + 240$$

where £ $x$  is the sales

£ $y$  is the total pay

(a) Complete the table.

$x$	0	400	800	1200	1600
$y$		360		600	

(2)

(b) On the grid, draw a graph to show how Nimer's total pay depends on his sales.

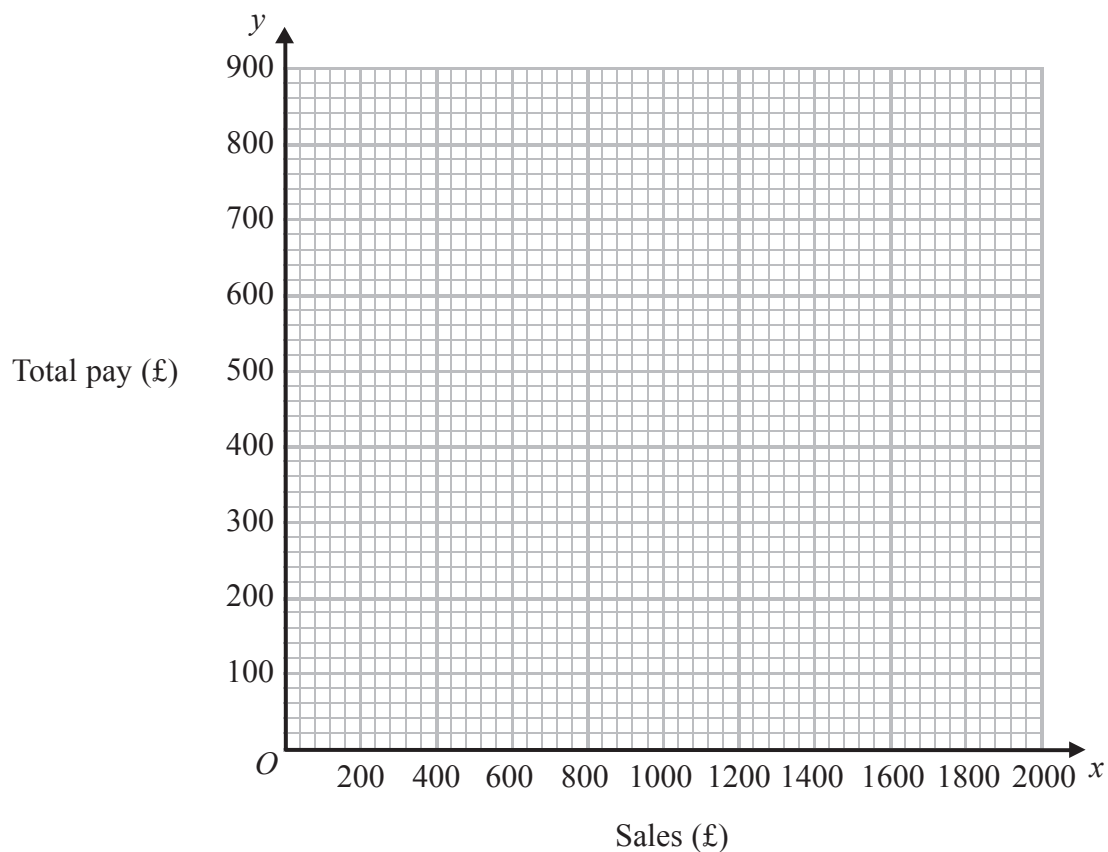

(2)

(Total for Question 24 is 4 marks)



\*25 The diagram represents the floor of a village hall.

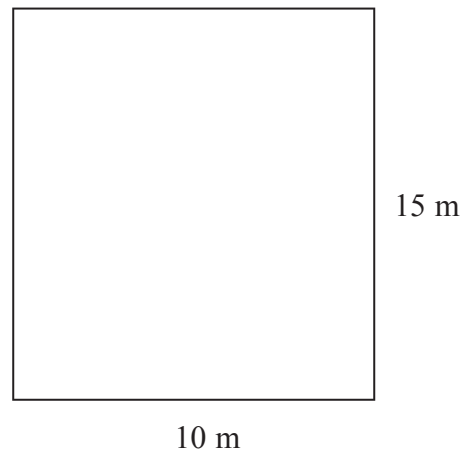

Diagram **NOT**  
accurately drawn

The floor is in the shape of a rectangle.  
The width is 10 m.  
The length is 15 m.

The floor is going to be waxed.

1 litre of wax will cover  $20 \text{ m}^2$  of floor.  
The wax is sold in pots of 2 litres.  
The cost of a pot of wax is £32.40

All the wax has to be bought.  
Work out the total cost of the pots of wax that have to be bought.  
You must show how you got your answer.

---

(Total for Question 25 is 5 marks)

---

**TOTAL FOR PAPER IS 100 MARKS**



**BLANK PAGE**

