

Write your name here

Surname

Other names

Centre Number

Candidate Number

Edexcel GCSE

Applications of Mathematics

Unit 2: Applications 2

For Approved Pilot Centres ONLY

Higher Tier

Thursday 8 November 2012 – Afternoon

Time: 1 hour 45 minutes

Paper Reference

5AM2H/01

You must have: Ruler graduated in centimetres and millimetres, protractor, pair of compasses, pen, HB pencil, eraser, calculator. Tracing paper may be used.

Total Marks

Instructions

- Use **black** ink or ball-point pen.
- **Fill in the boxes** at the top of this page with your name, centre number and candidate number.
- Answer **all** questions.
- Answer the questions in the spaces provided – *there may be more space than you need.*
- **Calculators may be used.**
- If your calculator does not have a π button, take the value of π to be 3.142 unless the question instructs otherwise.



Information

- The total mark for this paper is 100
- The marks for **each** question are shown in brackets – *use this as a guide as to how much time to spend on each question.*
- Questions labelled with an **asterisk** (*) are ones where the quality of your written communication will be assessed.

Advice

- Read each question carefully before you start to answer it.
- Keep an eye on the time.
- Try to answer every question.
- Check your answers if you have time at the end.

Turn over ►

P40657A

©2012 Pearson Education Ltd.

6/6/7/



PEARSON

GCSE Mathematics 2AM01

Formulae: Higher Tier

**You must not write on this formulae page.
Anything you write on this formulae page will gain NO credit.**

Volume of prism = area of cross section \times length

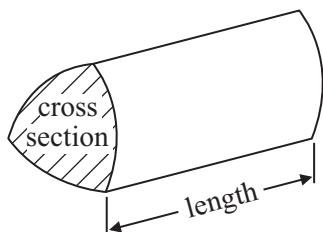

Area of trapezium = $\frac{1}{2} (a + b)h$

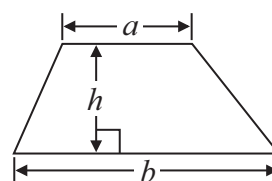

Volume of sphere = $\frac{4}{3} \pi r^3$

Surface area of sphere = $4\pi r^2$

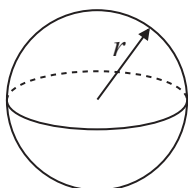

Volume of cone = $\frac{1}{3} \pi r^2 h$

Curved surface area of cone = $\pi r l$

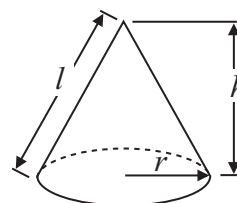

In any triangle ABC

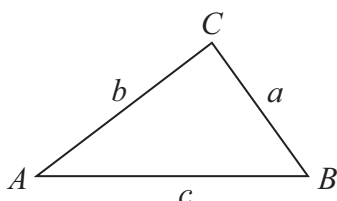

The Quadratic Equation

The solutions of $ax^2 + bx + c = 0$
where $a \neq 0$, are given by

$$x = \frac{-b \pm \sqrt{b^2 - 4ac}}{2a}$$

Sine Rule $\frac{a}{\sin A} = \frac{b}{\sin B} = \frac{c}{\sin C}$

Cosine Rule $a^2 = b^2 + c^2 - 2bc \cos A$

Area of triangle = $\frac{1}{2} ab \sin C$



Answer ALL questions.

Write your answers in the spaces provided.

You must write down all stages in your working.

*1 The diagram shows the side view of a kitchen step ladder.

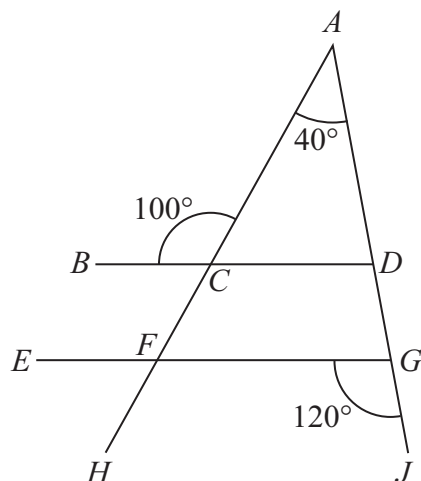

Diagram **NOT**
accurately drawn

Brian says the straight lines BCD and EFG are parallel.

Is Brian correct?

You must show all your working.

Give reasons for your answer.

(Total for Question 1 is 3 marks)



- 2 Jason sells shirts.
He needs to work out the selling price of the shirts.

He uses the formula

$$y = 2x + 10$$

where x is the cost price of a shirt in pounds (£)
and y is the selling price of a shirt in pounds (£)

- (a) On the grid, draw a graph that shows the relationship between the selling price and the cost price of a shirt.

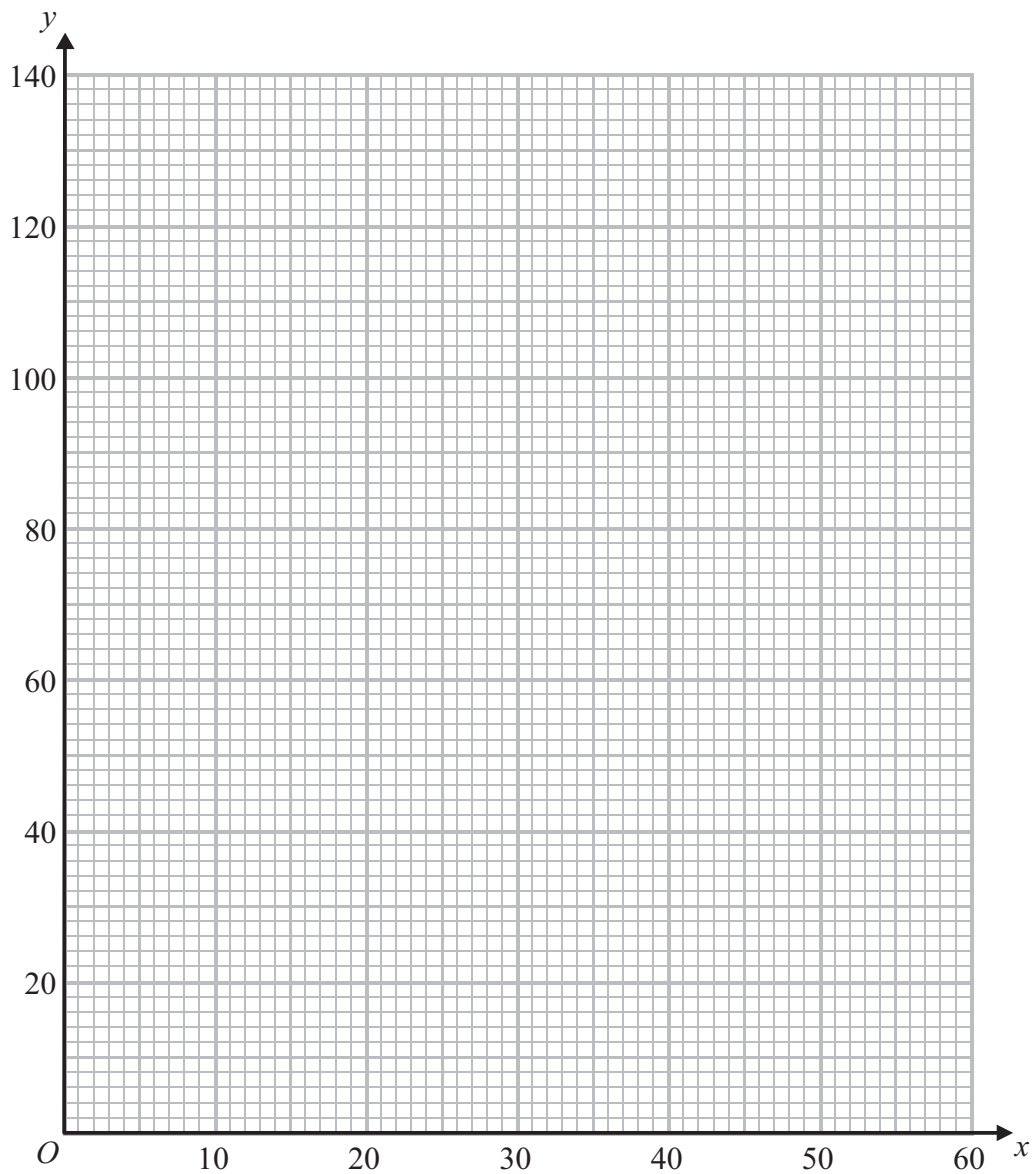

(3)



Meg is Jason's business partner.

She wants to use a different formula to work out the selling price of the shirts.

Meg's formula is

$$y = x + 25$$

where x is the cost price of a shirt in pounds (£)

and y is the selling price of a shirt in pounds (£)

There is only one value of x when the two formulas give the same selling price.

(b) Find this value of x .

.....
(3)

(Total for Question 2 is 6 marks)



3 Here is a diagram of a house.

The house is in the shape of a prism.

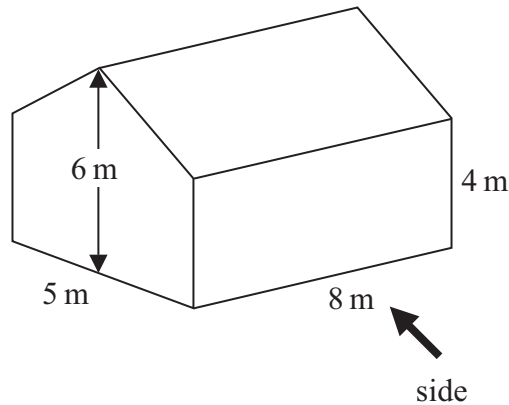
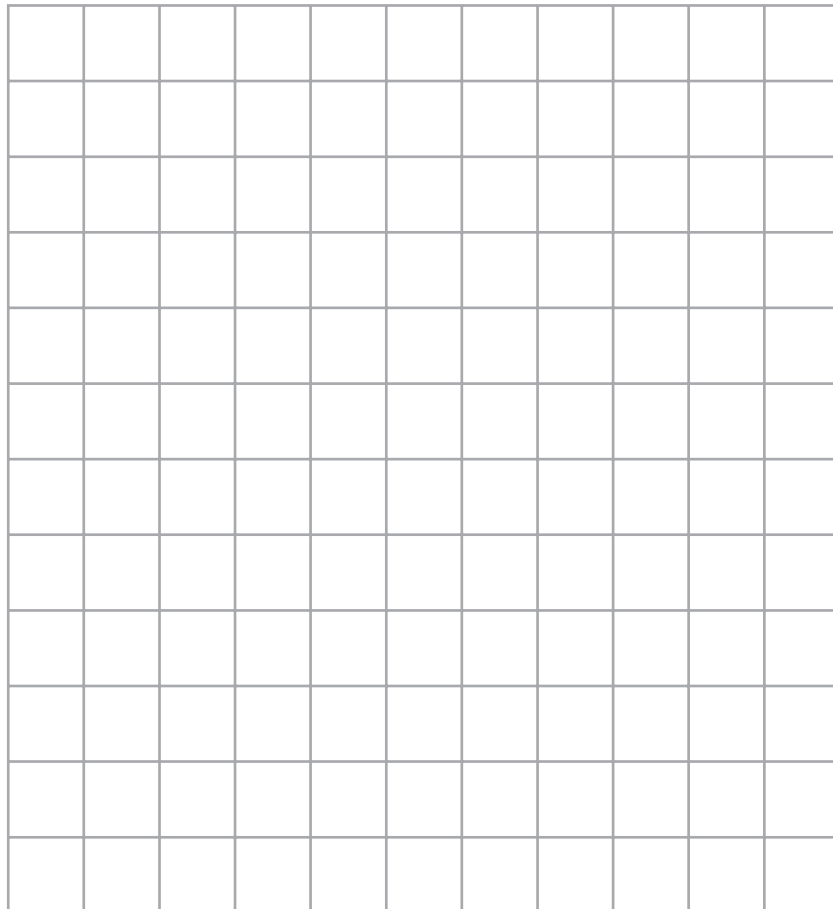

Diagram **NOT** accurately drawn

On the grid, draw accurately the side elevation of the house from the direction marked with the arrow.

Use the scale 1 cm represents 1 m.



(Total for Question 3 is 2 marks)



4 There are only red pens and blue pens in a box.

There are 12 red pens in the box.

The probability of taking at random a blue pen from the box is $\frac{2}{3}$

Work out the total number of pens in the box.

.....
(Total for Question 4 is 3 marks)



5 Stefan is x years old.

Martin is 5 years younger than Stefan.

James is twice as old as Stefan.

The sum of their ages, in years, is less than 30

Work out the oldest age Stefan can be.

Give your answer as a whole number of years.

.....years

(Total for Question 5 is 4 marks)



6 A compost bin is in the shape of a prism.

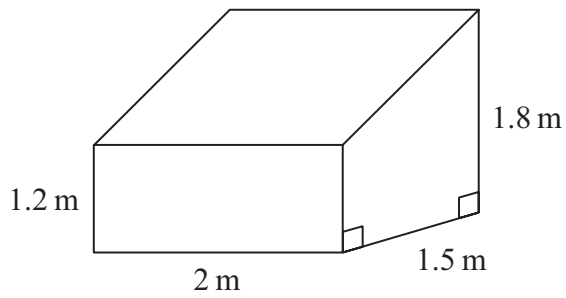

Diagram **NOT**
accurately drawn

Work out the volume of the compost bin.

.....m³

(Total for Question 6 is 4 marks)



7 There are 36 small rulers in a packet.

There are 24 large rulers in a box.

A shopkeeper needs to work out the total number of rulers, T , in x packets and y boxes.

Write down a formula for T in terms of x and y .

.....
(Total for Question 7 is 3 marks)

8 Here is the side view of a sandwich carton.

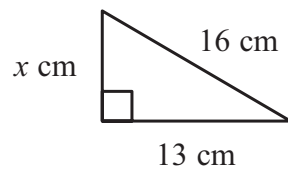

Diagram **NOT**
accurately drawn

- (a) Work out the value of x .
Give your answer correct to 3 significant figures.

.....
(3)



The diagram shows the same sandwich carton.
It is in the shape of a triangular prism.
The diagram also shows a box in the shape of a cuboid.

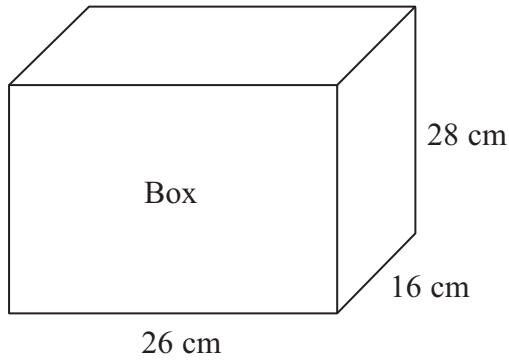
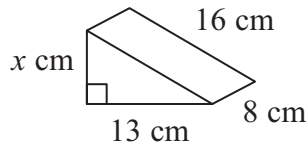

Diagram **NOT**
accurately drawn

Nina has to fill the box with sandwich cartons.

(b) Work out the greatest number of sandwich cartons she can put in the box.

.....
(3)

(Total for Question 8 is 6 marks)



9 The diagram shows a doorstep.

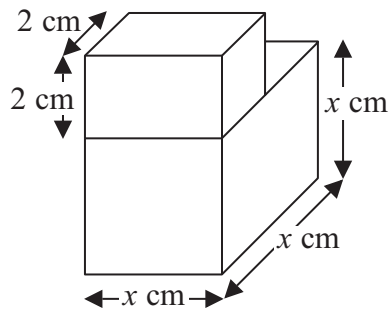

Diagram **NOT**
accurately drawn

The volume, $V \text{ cm}^3$, of the doorstep is given by the formula

$$V = x(x^2 + 4)$$

Use a trial and improvement method to find the value of x when $V = 100$
Give your answer correct to one decimal place.
You must show **ALL** your working.

$x = \dots\dots\dots$

(Total for Question 9 is 4 marks)



10 Here is a barrel.

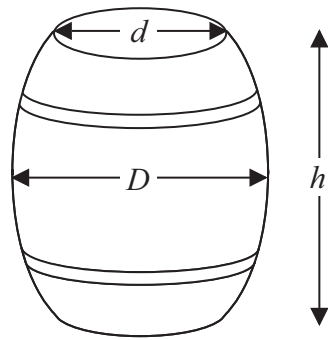

Diagram **NOT**
accurately drawn

The volume, $V \text{ m}^3$, of the barrel is given by the formula

$$V = \frac{2hD^2 + hd^2}{4}$$

$$d = 0.4 \text{ metres}$$

$$D = 1.25d$$

$$h = 1.5d$$

Work out the volume of the barrel.

.....metres³

(Total for Question 10 is 4 marks)



P 4 0 6 5 7 A 0 1 3 2 8

11 Raj has a bag of cubes.

There are 3 red cubes, 1 green cube, 3 blue cubes, 2 white cubes and 1 yellow cube in the bag.

Raj takes at random a cube from the bag.

He then puts the cube back into the bag.

Raj does this 50 times.

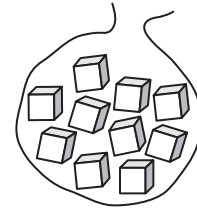

(a) Work out an estimate for the number of times Raj will take a red cube from the bag.

(2)

Raj's school is raising money for charity.

Raj uses his bag of cubes for a game.

Each person pays 10p to play the game.

Each person takes at random a cube from the bag.

Raj looks at the colour of the cube.

He then puts the cube back in the bag.

Each person gets the prize value of that colour shown in the table.

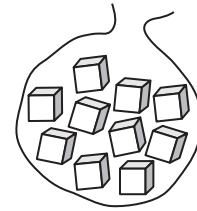

Colour	red	green	blue	white	yellow
Prize value	20p	10p	5p	2p	1p

*(b) Is Raj likely to raise any money for charity with his game?

You must explain your answer.

(3)

(Total for Question 11 is 5 marks)



12 A baker makes jam rolls.

The baker uses flour, butter and jam in the ratio 8 : 4 : 5 to make jam rolls.

The table shows the cost per kilogram of some of these ingredients.

Cost per kilogram	
Flour	40p
Butter	£2.50
Jam	£1.00

The total weight of the flour, butter and jam for each jam roll is 425 g.

Work out the cost of these ingredients for 200 jam rolls.

£.....

(Total for Question 12 is 6 marks)



13 Naomi is playing a board game.
She must throw two fair dice.

She must get a 6 on each dice to start the game.

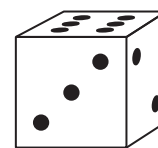
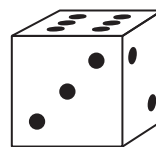

Work out the probability that she will **not** start the game on her first throw.

.....
(Total for Question 13 is 3 marks)



- 14 A steel rod has a density of 7.6 g per cm^3 .
The rod has a mass of 200 g .



steel rod

Work out the volume of the rod.
Give your answer correct to 3 significant figures.

.....
(Total for Question 14 is 3 marks)



P 4 0 6 5 7 A 0 1 7 2 8

15 Silas throws a ball vertically upwards.

The graph shows the height, h metres, of the ball above the ground, t seconds after Silas throws the ball.

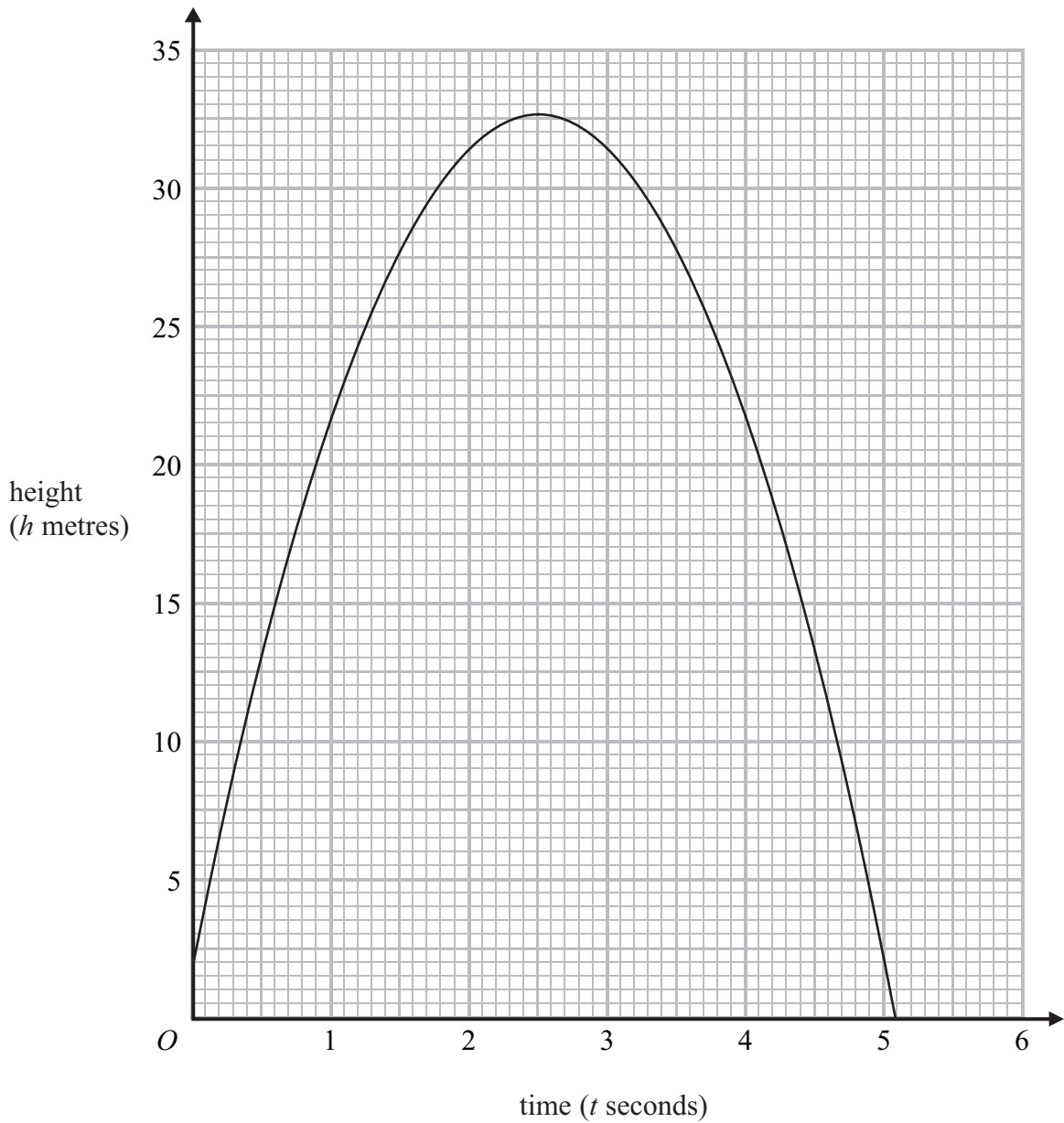

(a) Write down the maximum height of the ball above the ground.

.....m
(1)



(b) After how many seconds is the ball at a height of 18 metres above the ground?

.....
(2)

(c) Work out an estimate for the speed of the ball 2 seconds after Silas throws it.

.....m/s
(3)

(Total for Question 15 is 6 marks)



16 PQR is the side of a vertical building.

AB is a ramp.

AP is horizontal ground.

BQ is a horizontal path.

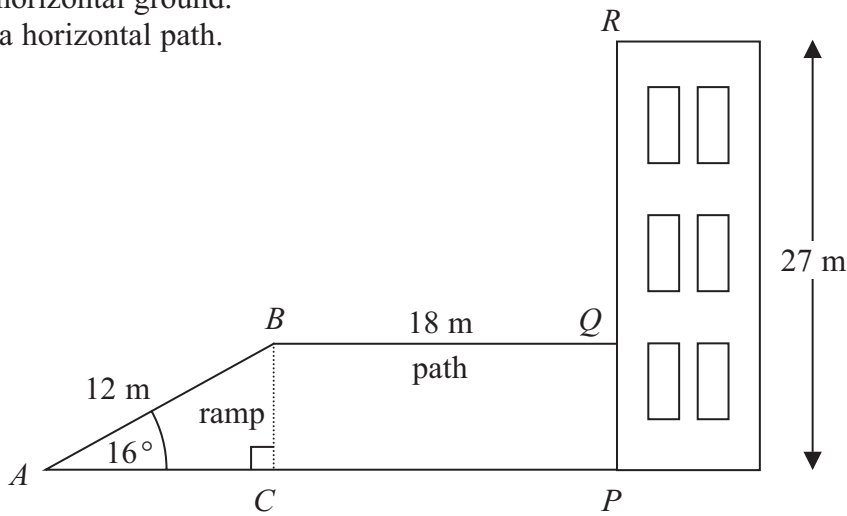

Diagram **NOT** accurately drawn

The building has a height of 27 m.

The ramp AB is at an angle of 16° to the horizontal ground.

The ramp has a length of 12 m.

The path has a length of 18 m.

- (a) Work out the height of the ramp.
Give your answer correct to 3 significant figures.

.....m
(3)

- (b) Calculate the angle of elevation of the top of the building, R , from the top of the ramp, B .
Give your answer correct to 3 significant figures.

.....
(3)

(Total for Question 16 is 6 marks)



17 Jake uses the formula $I = \frac{12}{R}$ in his science lesson.

(a) Complete the table of values for $I = \frac{12}{R}$

<i>R</i>	2	4	6	8	10	12
<i>I</i>	6		2		1.2	

(2)

(b) On the grid, draw the graph of $I = \frac{12}{R}$

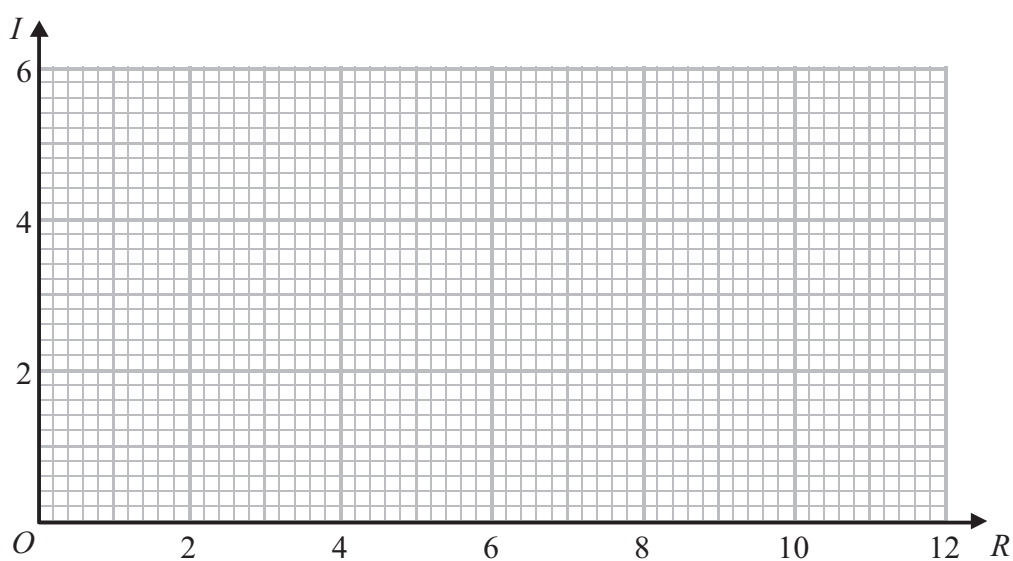

(2)

(Total for Question 17 is 4 marks)



18 Ben sells 30 raffle tickets.

7 of the tickets are pink.

13 of the tickets are yellow.

The rest of the tickets are blue.

Ben puts the 30 tickets in a bag.

Sophie takes at random 2 tickets from the bag.

Work out the probability that the 2 tickets are different colours.

.....
(Total for Question 18 is 5 marks)



- 19 The diagram shows a windscreen wiper on a car.
It also shows the area of the windscreen the wiper cleans.

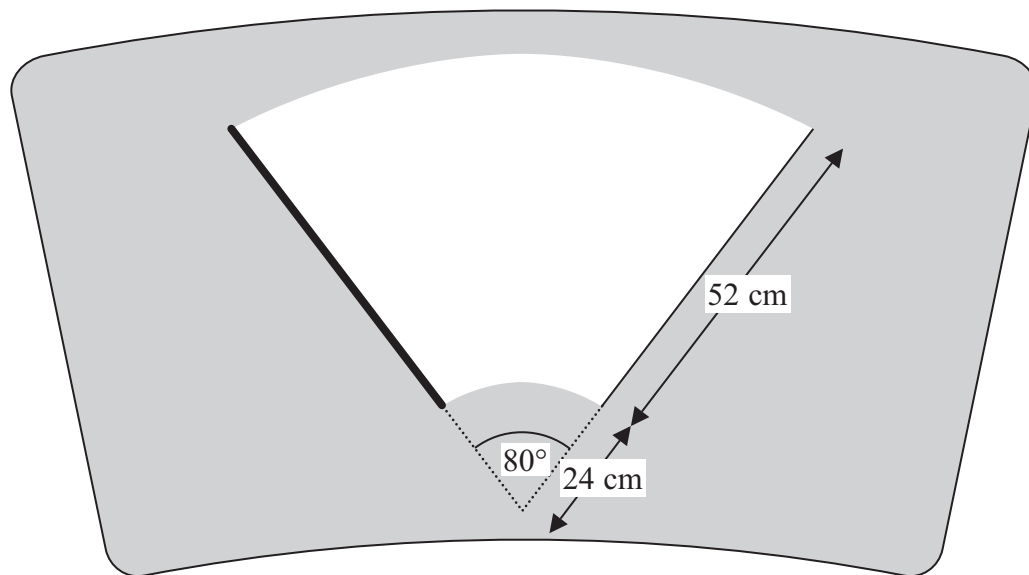

Diagram **NOT**
accurately drawn

Work out the area of the windscreen the wiper cleans.
Give your answer correct to 3 significant figures.

..... cm^2

(Total for Question 19 is 4 marks)



- *20 The diagram shows Diana's suitcase.
The suitcase is in the shape of a cuboid.

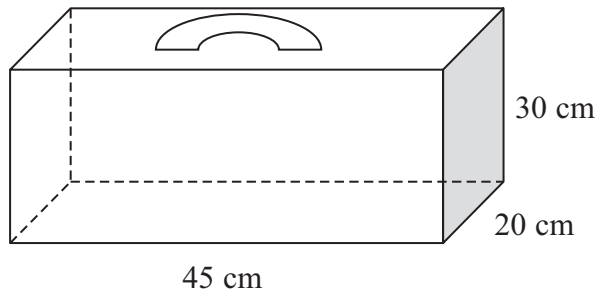

Diagram **NOT**
accurately drawn

Diana has a walking stick that folds.
The folded walking stick has a length of 60 cm.

Diana wants to put the folded walking stick in the suitcase.

Will the folded walking stick fit in the suitcase?

(Total for Question 20 is 4 marks)



21 The time, t seconds, it takes a pendulum to swing from its start position and back to its start position is directly proportional to the square root of its length, L cm.

A pendulum with a length of 100 cm takes 2 seconds to swing from its start position and back to its start position.

A different pendulum has a length of 64 cm.

How many seconds will it take this pendulum to swing from its start position and back to its start position?

.....seconds

(Total for Question 21 is 4 marks)



22 Pietro cycled to work.

His average speed was 6.0 m/s correct to 1 decimal place.
It took him 15 minutes correct to the nearest minute.

- (a) Calculate the lower bound of the distance Pietro cycled to work.
Give your answer in kilometres.

..... km
(3)

Pietro took a different route home from work.

He cycled a distance of 4.6 km correct to 1 decimal place.
It took him 17 minutes correct to the nearest minute.

- (b) Calculate the upper bound of Pietro's average speed for his journey home from work.
Give your answer in m/s.

..... m/s
(3)

(Total for Question 22 is 6 marks)



23 At the beginning of December 2010 there were 8400 bees in a beehive.
The number of bees in the beehive increases by 7% each year.

In which year will there be at least 15 000 bees in the beehive?

.....
(Total for Question 23 is 5 marks)

TOTAL FOR PAPER IS 100 MARKS



BLANK PAGE

