

Write your name here

Surname

Other names

Centre Number

Candidate Number

Edexcel GCSE

Methods in Mathematics

Unit 2: Methods 2

For Approved Pilot Centres ONLY

Foundation Tier

Thursday 17 November 2011 – Morning

Time: 1 hour 45 minutes

Paper Reference

5MM2F/01

You must have: Ruler graduated in centimetres and millimetres, protractor, pair of compasses, pen, HB pencil, eraser, calculator. Tracing paper may be used.

Total Marks

Instructions

- Use **black** ink or ball-point pen.
- **Fill in the boxes** at the top of this page with your name, centre number and candidate number.
- Answer **all** questions.
- Answer the questions in the spaces provided – *there may be more space than you need.*
- **Calculators may be used.**
- If your calculator does not have a π button, take the value of π to be 3.142 unless the question instructs otherwise.



Information

- The total mark for this paper is 100
- The marks for **each** question are shown in brackets – *use this as a guide as to how much time to spend on each question.*
- Questions labelled with an **asterisk** (*) are ones where the quality of your written communication will be assessed.

Advice

- Read each question carefully before you start to answer it.
- Keep an eye on the time.
- Try to answer every question.
- Check your answers if you have time at the end.

P40604A

©2011 Edexcel Limited.

6/6/6



P 4 0 6 0 4 A 0 1 2 4

Turn over ►

edexcel 
advancing learning, changing lives

GCSE Mathematics 2MM01

Formulae: Foundation Tier

**You must not write on this formulae page.
Anything you write on this formulae page will gain NO credit.**

Area of trapezium = $\frac{1}{2}(a + b)h$

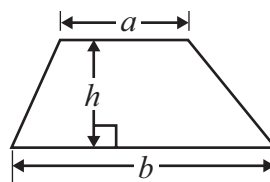

Volume of prism = area of cross section \times length

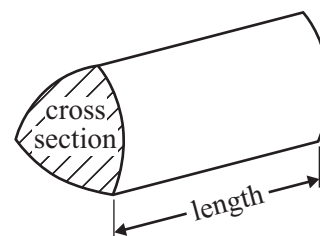

Answer ALL questions.

Write your answers in the spaces provided.

You must write down all stages in your working.

1 (a) Work out $52.3 - 27.06$

.....
(1)

(b) Work out $127.8 \div 2.4$

.....
(1)

(c) Work out $2 \times (2.5 + 3.7)$

.....
(1)

(d) Work out $5.9 + 3.17^2$

.....
(1)

(Total for Question 1 is 4 marks)



2 Here is a solid prism made from centimetre cubes.

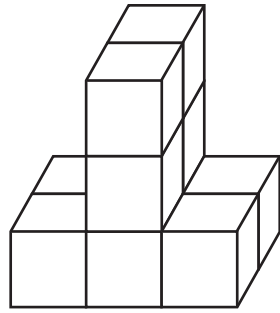

Diagram **NOT**
accurately drawn

Find the volume of the prism.

..... cm³

(Total for Question 2 is 1 mark)



3 (a) Write 0.81 as a percentage.

..... %
(1)

(b) Write 0.7 as a fraction.

.....
(1)

(c) Work out 50% of 24

.....
(1)

(d) Work out $\frac{1}{4}$ of 40

.....
(1)

(e) Write $\frac{2}{9}$ as a decimal.

.....
(1)

(f) Write the ratio 6 : 10 in its simplest form.

..... :
(1)

*(g) Which is bigger $\frac{4}{5}$ or 75%?

Give a reason for your answer.

(3)

(Total for Question 3 is 9 marks)



4 Here is a polygon.

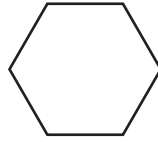

(a) Write down the special name of this polygon.

.....
(1)

Here are some more polygons.

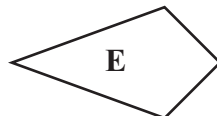
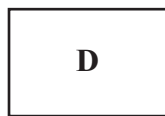
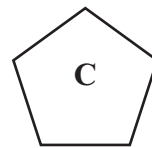
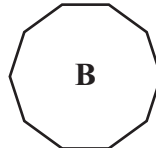
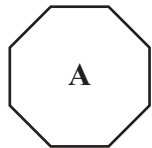

(b) (i) Write down the letter of the shape which is an octagon.

.....

(ii) Write down the letter of the shape which is a heptagon.

.....

(2)

(Total for Question 4 is 3 marks)



5 Here is a list of temperatures.

-2°C 4°C -7°C 15°C 0°C -5°C 3°C

(a) From the list,

(i) write down the highest temperature,

..... $^{\circ}\text{C}$

(ii) write down the lowest temperature.

..... $^{\circ}\text{C}$

(2)

(b) Increase -7°C by 9°C .

..... $^{\circ}\text{C}$

(1)

(c) Work out the difference between -5°C and -2°C .

..... $^{\circ}\text{C}$

(1)

(Total for Question 5 is 4 marks)

*6 Which is bigger

15% of 240 or $\frac{1}{8}$ of 320?

(Total for Question 6 is 4 marks)



7 Here is a trapezium.

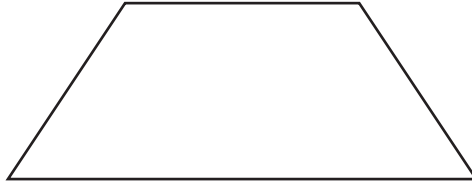

(a) On the trapezium, mark with arrows (\gg) the pair of parallel lines.

(1)

Here are two shapes.

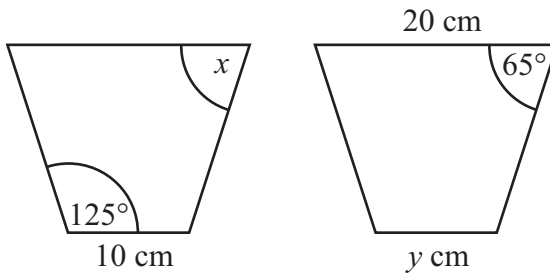

Diagram **NOT** accurately drawn

The shapes are congruent.

(b) (i) Write down the size of the angle marked x .

.....
o

(ii) Write down the value of y .

.....
(2)

(Total for Question 7 is 3 marks)



8 (a) Work out

(i) 2.5^3

(ii) $\sqrt{7.84}$

(iii) $\sqrt[3]{1.331}$

.....
.....
.....
(3)

(b) Find the number that should be written in each empty box.

(i) $3.5 \times \boxed{\text{.....}} = 3500$

(ii) $7.8 \div \boxed{\text{.....}} = 0.078$

(iii) $1 \div \boxed{\text{.....}} = 5$

(3)

(c) Work out $\frac{-3.5 \times 2.8}{-1.4}$

.....
(2)

(Total for Question 8 is 8 marks)



9 Here is a quadrilateral.

Diagram **NOT**
accurately drawn

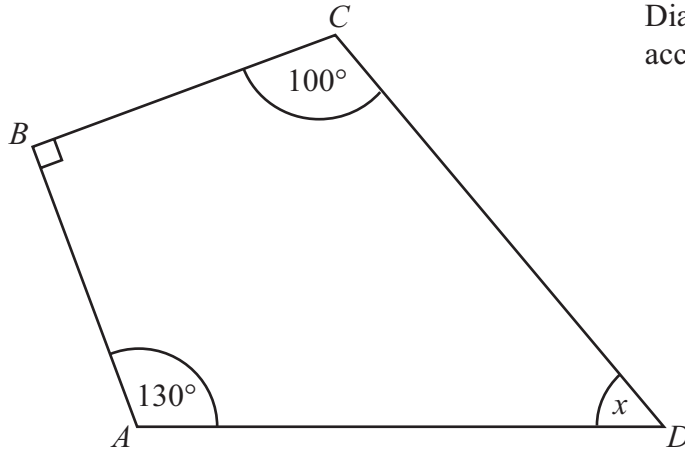

(i) Find the size of the angle marked x .

(ii) Give a reason for your answer.

(Total for Question 9 is 3 marks)



10 Here are some triangles.

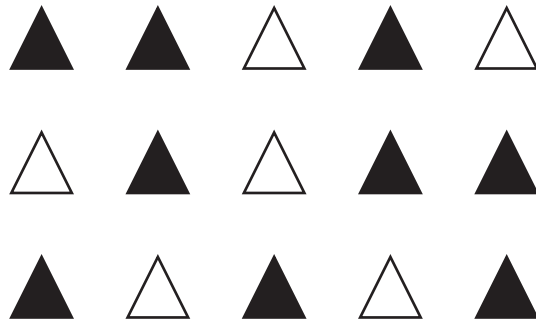

- (a) What fraction of these triangles are shaded?
Give your fraction in its simplest form.

.....
(2)

Tony takes some of these triangles.

He takes shaded triangles and unshaded triangles in the ratio 2 : 1

- (b) Work out the greatest number of unshaded triangles he could take.

.....
(2)

(Total for Question 10 is 4 marks)



11 (a) Work out the output for this number machine.



.....
(2)

(b) Work out the input for this number machine.



.....
(2)

(c) The input for this number machine is m .

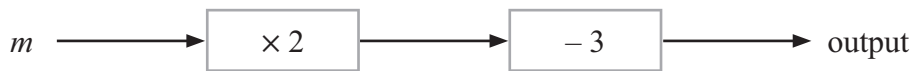

Find an expression, in terms of m , for the output.

.....
(2)

(d) The output for this number machine is n .



Find an expression, in terms of n , for the input.

.....
(2)

(Total for Question 11 is 8 marks)



12 Here is a cuboid.

Diagram **NOT**
accurately drawn

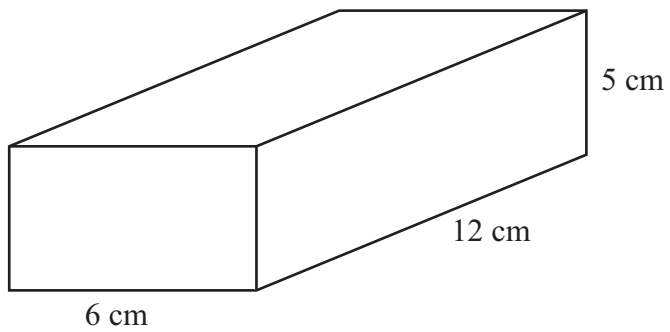

Work out the total surface area of the cuboid.

.....
(Total for Question 12 is 4 marks)



13 (a) Here is a list of fractions.

$\frac{1}{2}$	$\frac{1}{5}$	$\frac{1}{10}$	$\frac{1}{3}$	$\frac{1}{4}$	$\frac{1}{8}$
---------------	---------------	----------------	---------------	---------------	---------------

(i) From the list, write down the smallest fraction.

(ii) From the list, write down **two** fractions bigger than $\frac{1}{5}$

.....

.....

(2)

(b) Is $\frac{1}{3}$ half way between $\frac{1}{2}$ and $\frac{1}{4}$?

You must show your working.

(2)

(Total for Question 13 is 4 marks)



14

Diagram **NOT**
accurately drawn

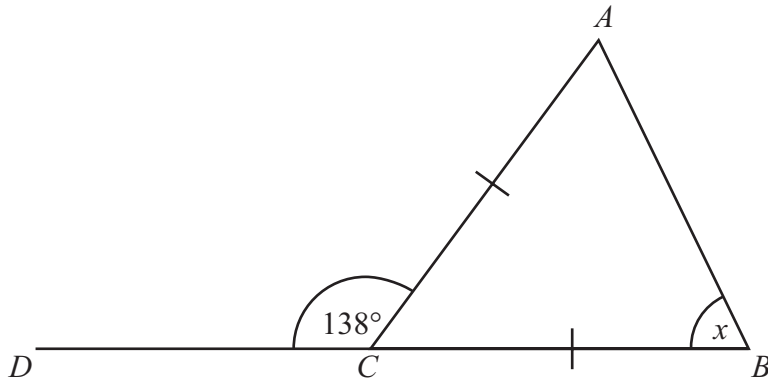

DCB is a straight line.

$AC = CB$.

Angle $ACD = 138^\circ$.

Work out the size of the angle marked x .

Give reasons for your answer.

(Total for Question 14 is 3 marks)

15 On the grid, show how the shape tessellates.

You must draw at least 6 shapes.

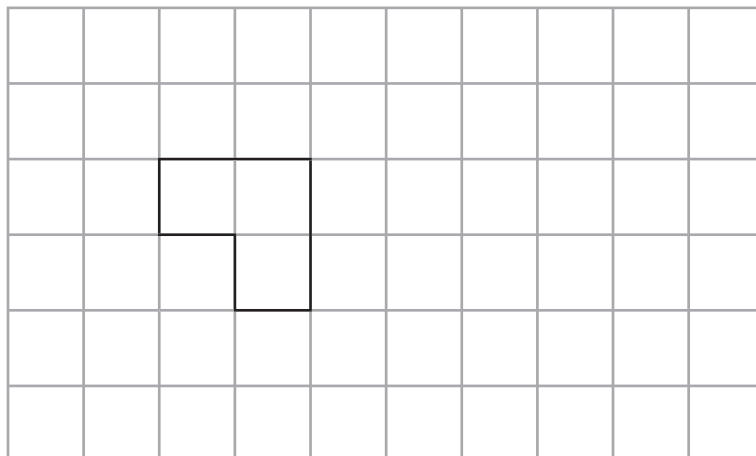

(Total for Question 15 is 2 marks)



16

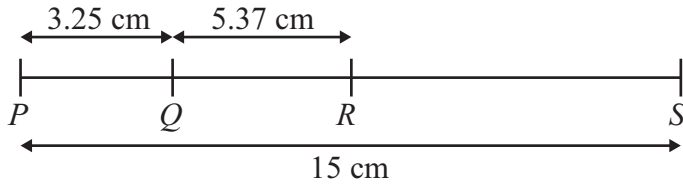

Diagram **NOT** accurately drawn

P, Q, R and S are points on a straight line.
 $PQ = 3.25$ cm.
 $QR = 5.37$ cm.
 $PS = 15$ cm.

(a) Work out the length of RS .

..... cm
(2)

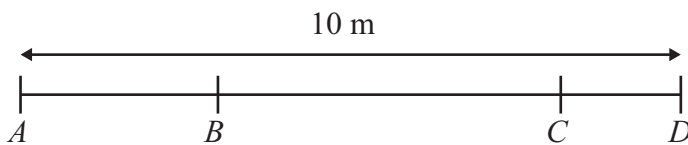

Diagram **NOT** accurately drawn

A, B, C and D are points on a straight line.
 $AD = 10$ m.
 $AC = 8.5$ m.
 $BD = 7.8$ m.

(b) Work out the length of BC .

..... m
(2)

(Total for Question 16 is 4 marks)



17 n is an integer and $-3 \leq n < 2$

(a) Write down all the possible values of n .

.....
(2)

Here is a number line.

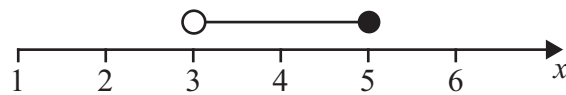

(b) Write down the inequality shown on the number line.

.....
(2)

(c) Solve $4x + 3 \leq 18$

.....
(2)

(Total for Question 17 is 6 marks)



18 The diagram shows a solid prism.

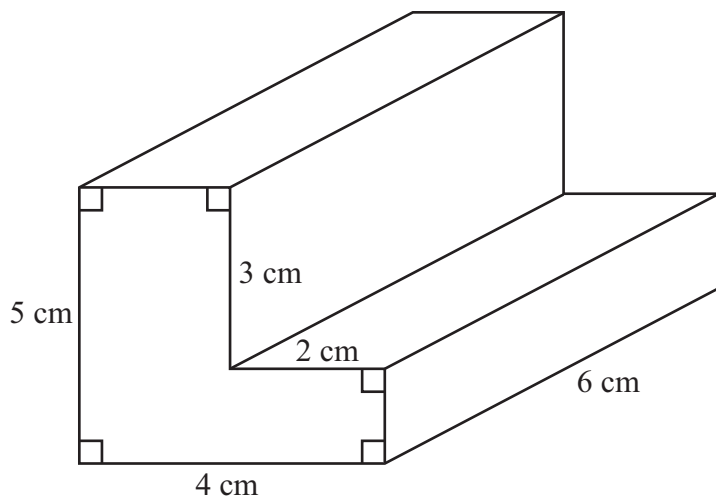

Diagram **NOT** accurately drawn

Work out the volume of the prism.

..... cm³

(Total for Question 18 is 4 marks)



19 $A = 5b + 7$

(a) Work out the value of A when $b = 8$

.....
(2)

$$v = u + 10t$$

$$u = 5$$

$$t = 2.5$$

(b) Work out the value of v .

.....
(2)

(c) Make t the subject of the formula $v = u + 10t$

$$t = \text{.....}$$

(3)

(Total for Question 19 is 7 marks)



20 (a) Work out the size of an exterior angle of a regular pentagon.

.....
(2)

(b) Work out the size of an interior angle of a regular pentagon.

.....
(2)

(Total for Question 20 is 4 marks)



21 The diagram shows a circle inside a semicircle.

Diagram **NOT**
accurately drawn

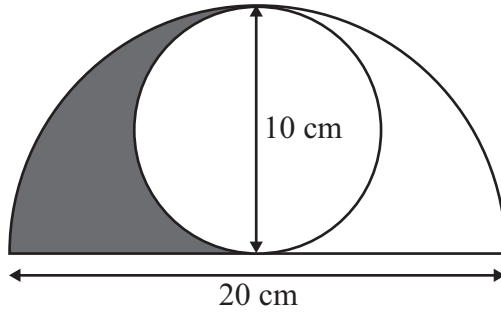

The circle has a diameter of 10 cm.
The semicircle has a diameter of 20 cm.

Work out the area shaded.
Give your answer correct to 1 decimal place.

..... cm²

(Total for Question 21 is 5 marks)



22 (a) Complete the table of values for $y = x^2 - 3$

x	-3	-2	-1	0	1	2	3
y	6		-2		-2	1	

(2)

(b) On the grid, draw the graph of $y = x^2 - 3$ for values of x from -3 to 3

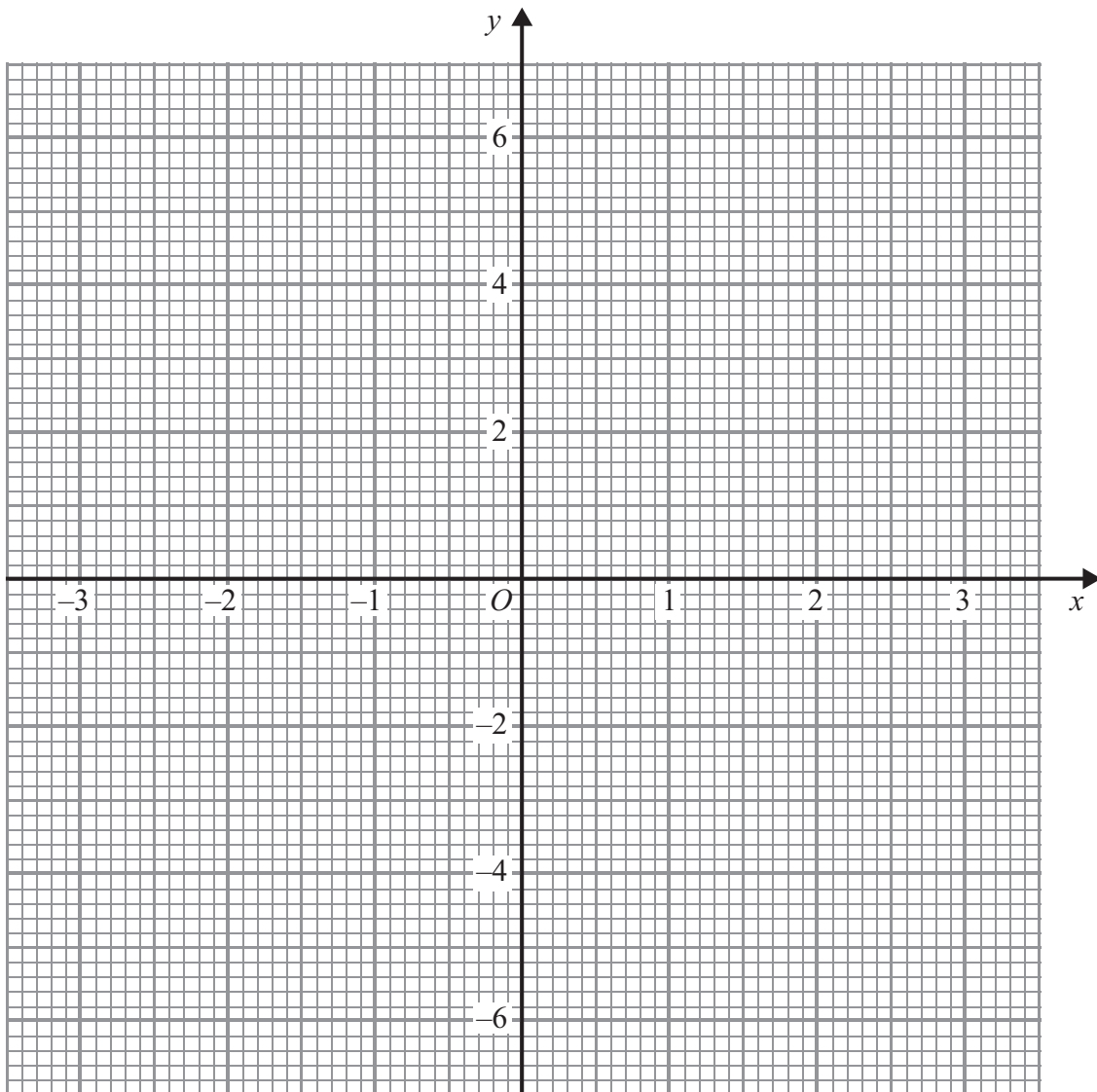

(2)

(c) Use the graph to find estimates of the values of x when $x^2 - 3 = 0$

.....
(2)

(Total for Question 22 is 6 marks)

TOTAL FOR PAPER IS 100 MARKS



BLANK PAGE



BLANK PAGE

