

Surname	Initial(s)
Signature	

Paper Reference(s)

5382F/07

Edexcel GCSE

Mathematics (Modular) – 2381

Paper 7 (Non-Calculator)

Foundation Tier



Unit 2 Stage 1

Tuesday 3 March 2009 – Afternoon

Time: 30 minutes

Materials required for examination

Multiple Choice Answer Sheet
Ruler graduated in centimetres and millimetres, protractor, compasses, HB pencil, eraser.

Items included with question papers

Nil

Instructions to Candidates

Use a HB pencil. Do not open this booklet until you are told to do so.

Before the test begins:

Check that the answer sheet is for the correct test and that it contains your candidate details.

How to answer the test:

For each question, choose the right answer, A, B, C, D or E and mark it in HB pencil on the answer sheet.

For example, the answer C would be marked as shown.

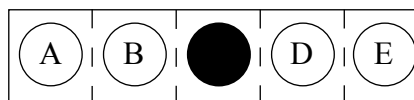

Mark only **one** answer for each question. If you change your mind about an answer, rub out the first mark **completely**, then mark your new answer.

Answer **all** the questions.

Do any necessary calculations and rough work in this booklet. **Calculators must not be used.**

You must not take this booklet or the answer sheet out of the examination room.

Information for Candidates

There are 25 questions in this question paper. The total mark for this paper is 25.

There are 12 pages in this question paper. Any blank pages are indicated.

Advice to Candidates

Work steadily through the paper. Do not spend too long on one question.

If you cannot answer a question, leave it and attempt the next one.

Return at the end to those you have left out.

Printer's Log. No.

N34675A



N 3 4 6 7 5 A

Turn over

GCSE Mathematics 2381

Formulae: Foundation Tier

**You must not write on this formulae page.
Anything you write on this formulae page will gain NO credit.**

Area of trapezium = $\frac{1}{2}(a + b)h$

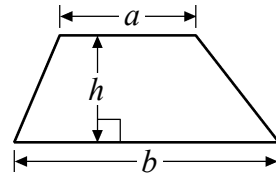

Volume of prism = area of cross section \times length

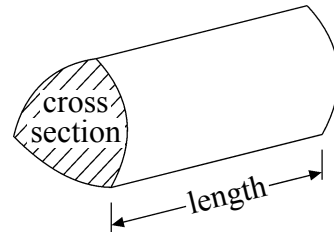

Answer ALL TWENTY FIVE questions using the answer sheet.

You must NOT use a calculator.

1. What is the value of the 6 in the number 36 825?

- 600 60 6 6000 60 000
A B C D E
-

2.

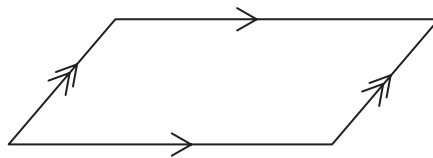

What is the special name for this quadrilateral?

- rectangle parallelogram rhombus kite trapezium
A B C D E
-

3. Here are the first four terms of a number sequence.

7 11 15 19

What is the next term of the sequence?

- 20 24 21 23 22
A B C D E
-

4.

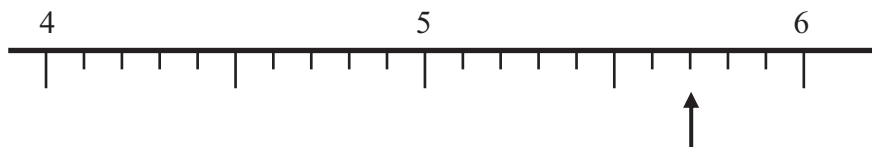

Which number is marked with the arrow?

- 5.07 6.3 5.7 5.2 57
A B C D E
-

5. Which of the marked angles is an acute angle?

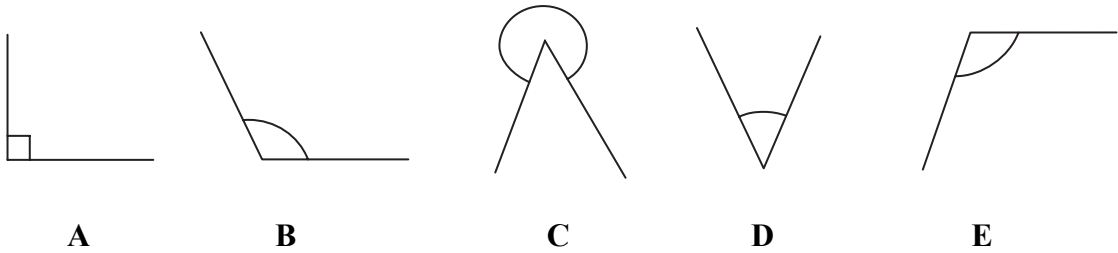

6. Which number is a factor of 15?

- | | | | | |
|----------|----------|----------|----------|----------|
| 30 | 5 | 10 | 2 | 20 |
| A | B | C | D | E |
-

7. A shaded shape has been drawn on the centimetre grid.

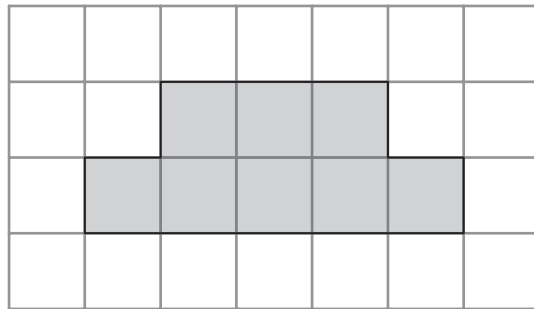

What is the perimeter of the shaded shape?

- | | | | | |
|----------|----------|----------|----------|----------|
| 15 cm | 20 cm | 14 cm | 8 cm | 12 cm |
| A | B | C | D | E |
-

8. Which number is the smallest?

- | | | | | |
|----------|----------|----------|----------|----------|
| 7.128 | 7.4 | 7.32 | 7.18 | 7.09 |
| A | B | C | D | E |
-

9. Oranges cost 24p each.

Raja buys 5 of the oranges.
He pays with a £5 note.

How much change should he get?

£3.80

A

£4.20

B

£1.20

C

£2.80

D

£4.76

E

10. What is 5 squared?

30

A

10

B

20

C

25

D

15

E

11.

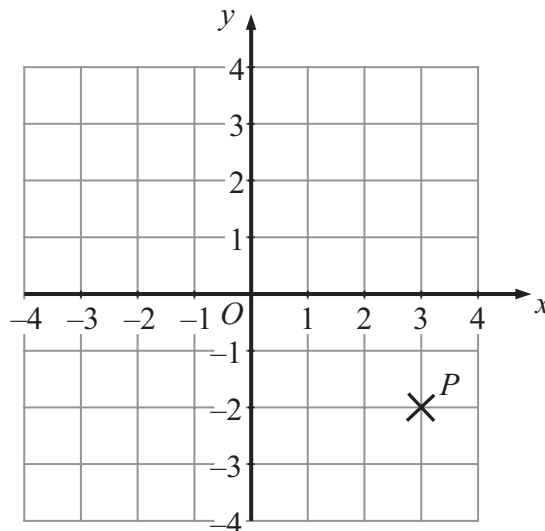

What are the coordinates of the point P ?

(-2, 3)

A

(2, -3)

B

(3, -2)

C

(-3, -2)

D

(-3, 2)

E

12. At 8 am, the temperature was -2°C .
At midday, the temperature was 6°C higher.

What was the temperature at midday?

- | | | | | |
|----------------------|---------------------|---------------------|---------------------|---------------------|
| -8°C | 4°C | 6°C | 2°C | 8°C |
| A | B | C | D | E |
-

13.

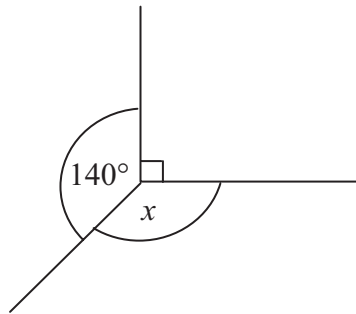

Diagram **NOT**
accurately drawn

What is the size of the angle marked x ?

- | | | | | |
|---------------|---------------|--------------|---------------|---------------|
| 140° | 130° | 40° | 150° | 220° |
| A | B | C | D | E |
-

14. $20 - (4 + 10) =$

- | | | | | |
|----------|----------|----------|----------|----------|
| 6 | -6 | 26 | 14 | -34 |
| A | B | C | D | E |
-

15. Here is a sequence of numbers.

10 7 8 5 6

What is the next number in the sequence?

- | | | | | |
|----------|----------|----------|----------|----------|
| 5 | 2 | 3 | 1 | 4 |
| A | B | C | D | E |
-

16. Here is a list of numbers.

0.4 $\frac{1}{3}$ $\frac{1}{4}$ $\frac{1}{2}$ 0.3

Sally is going to write the numbers in order of size.
She writes the smallest number first.

Which number should she write next?

0.4	$\frac{1}{3}$	$\frac{1}{4}$	$\frac{1}{2}$	0.3
A	B	C	D	E

17. A train leaves London at 16 53
It arrives in Peterborough at 18 22

How long does the journey take?

1 hour 29 minutes	2 hours 31 minutes	2 hours 9 minutes	2 hours 29 minutes	1 hour 31 minutes
A	B	C	D	E

18. Here are the first five terms of an arithmetic sequence.

5 9 13 17 21

What is the 15th term of this sequence?

57	65	61	63	60
A	B	C	D	E

19.

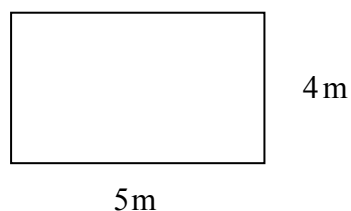

Diagram **NOT** accurately drawn

The diagram shows the plan of a rectangular floor.

Ann is going to cover the floor with carpet.
The carpet costs £15 per square metre.

What is the total cost of the carpet?

£150

£270

£200

£135

£300

A

B

C

D

E

20.

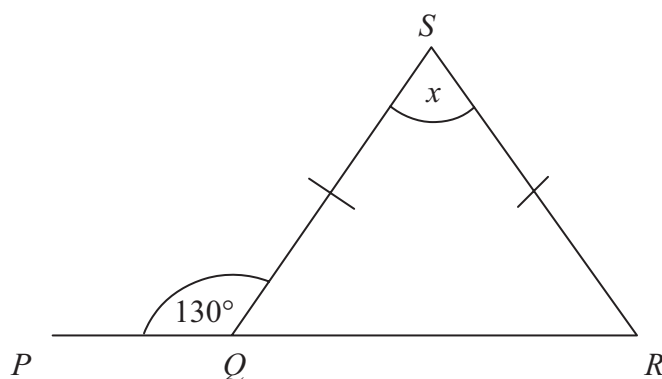

Diagram **NOT** accurately drawn

PQR is a straight line.
 $SQ = SR$.

What is the size of the angle marked x ?

50°

130°

70°

80°

60°

A

B

C

D

E

21. Given that $47 \times 81.6 = 3835.2$

What is the value of 0.47×816 ?

383.52

A

38352

B

38.352

C

3835.2

D

3.8352

E

22.

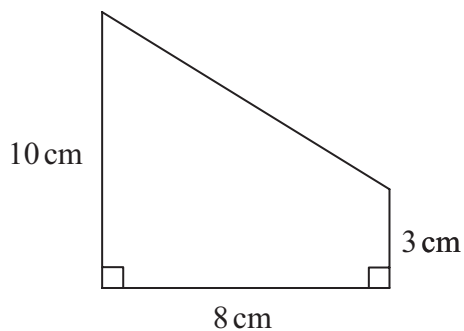

Diagram **NOT** accurately drawn

What is the area of this shape?

21 cm^2

A

52 cm^2

B

104 cm^2

C

80 cm^2

D

240 cm^2

E

23.

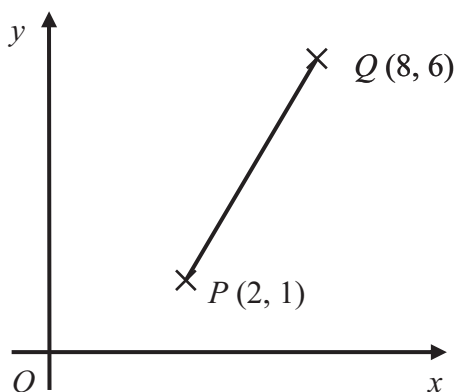

Diagram **NOT** accurately drawn

P is the point (2, 1).

Q is the point (8, 6).

Which are the coordinates of the midpoint of PQ ?

(4, 3)

A

$(4, 3\frac{1}{2})$

B

$(5, 3\frac{1}{2})$

C

$(5, 2\frac{1}{2})$

D

$(3, 2\frac{1}{2})$

E

24. What is the Lowest Common Multiple (LCM) of 24 and 60?

- | | | | | |
|----------|----------|----------|----------|----------|
| 2 | 120 | 12 | 1440 | 240 |
| A | B | C | D | E |
-

25. Here are the first five terms of an arithmetic sequence.

3 8 13 18 23

What is the expression, in terms of n , for the n th term of this sequence?

- | | | | | |
|----------|----------|----------|----------|----------|
| $n + 5$ | $5n$ | $5n + 3$ | $3n - 2$ | $5n - 2$ |
| A | B | C | D | E |
-

TOTAL FOR PAPER: 25 MARKS

END

BLANK PAGE

BLANK PAGE