

Centre No.						Paper Reference						Surname	Initial(s)	
Candidate No.						5	5	3	6	/	1	7	Signature	

Paper Reference(s)

**5536/17**

**Edexcel GCSE**

**Mathematics B – 1388**

Paper 17 (Calculator)

**Intermediate Tier**

Friday 9 November 2007 – Morning

Time: 1 hour 15 minutes



Examiner's use only

--	--	--

Team Leader's use only

--	--	--

**Materials required for examination**

Ruler graduated in centimetres and millimetres, protractor, compasses, pen, HB pencil, eraser, calculator. Tracing paper may be used.

**Items included with question papers**

Nil

**Instructions to Candidates**

In the boxes above, write your centre number, candidate number, your surname, initials and signature. Check that you have the correct question paper.

Answer ALL the questions. Write your answers in the spaces provided in this question paper.

**You must NOT write on the formulae page. Anything you write on the formulae page will gain NO credit.**

If you need more space to complete your answer to any question, use additional answer sheets.

**Information for Candidates**

The marks for individual questions and the parts of questions are shown in round brackets: e.g. (2).

There are 19 questions in this question paper. The total mark for this paper is 62.

There are 16 pages in this question paper. Any blank pages are indicated.

**Calculators may be used.**

If your calculator does not have a  $\pi$  button, take the value of  $\pi$  to be 3.142 unless the question instructs otherwise.

**Advice to Candidates**

Show all stages in any calculations.

Work steadily through the paper. Do not spend too long on one question.

If you cannot answer a question, leave it and attempt the next one.

Return at the end to those you have left out.

This publication may be reproduced only in accordance with Edexcel Limited copyright policy. ©2007 Edexcel Limited.

Printer's Log. No.  
**H31120A**

W850/R5536/57570 6/6/6/3/



*Turn over*

**edexcel**   
advancing learning, changing lives

**GCSE Mathematics 1387/8**

Formulae: Intermediate Tier

**You must not write on this formulae page.  
Anything you write on this formulae page will gain NO credit.**

**Area of trapezium** =  $\frac{1}{2}(a+b)h$

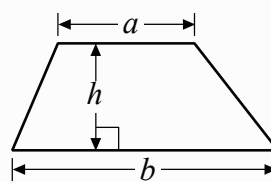

**Volume of prism** = area of cross section  $\times$  length

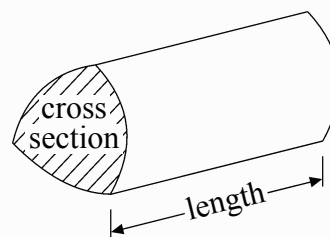

Leave  
blank

**Answer ALL NINETEEN questions.**

**Write your answers in the spaces provided.**

**You must write down all stages in your working.**

1. Plain tiles cost 28p each.  
Patterned tiles cost £9.51 each.

Julie buys 450 plain tiles and 15 patterned tiles.

- (a) Work out the total cost of the tiles.

£.....  
**(3)**

Fred lays the tiles.  
He charges £360 plus VAT at 17.5%.

- (b) Work out the total amount that Fred charges.

£.....  
**(3)**

**(Total 6 marks)**

**Q1**



<p>2. (a) Solve <math>x + x + x = 15</math></p> <p style="text-align: right;"><math>x = \dots\dots\dots</math> <b>(1)</b></p> <p>(b) Solve <math>4y + 1 = 12</math></p> <p style="text-align: right;"><math>y = \dots\dots\dots</math> <b>(2)</b></p> <p>(c) Simplify <math>cd + 2cd</math></p> <p style="text-align: right;"><math>\dots\dots\dots</math> <b>(1)</b></p> <p>(d) Simplify <math>4p + 3q - p - 4q</math></p> <p style="text-align: right;"><math>\dots\dots\dots</math> <b>(2)</b></p> <p style="text-align: right;"><b>(Total 6 marks)</b></p>	<p>Leave blank</p> <p style="text-align: center;"><b>Q2</b></p> <div style="border: 1px solid black; width: 20px; height: 20px; margin: 0 auto;"></div>
<p>3. Use ruler and compasses to construct an equilateral triangle with sides of length 7 centimetres. You must show all your construction lines. One side of the triangle has already been drawn for you.</p> <p style="text-align: center;"><math>\text{-----}</math></p> <p style="text-align: right;"><b>(Total 2 marks)</b></p>	<p style="text-align: center;"><b>Q3</b></p> <div style="border: 1px solid black; width: 20px; height: 20px; margin: 0 auto;"></div>



Leave blank

4.

Diagram **NOT** accurately drawn

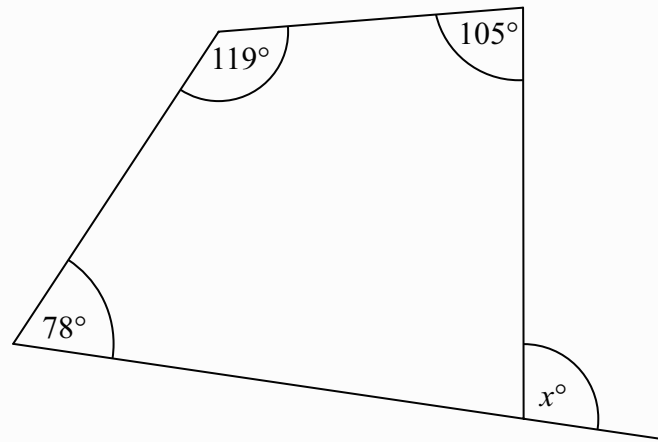

Work out the value of  $x$ .

$x = \dots\dots\dots$

**Q4**

**(Total 3 marks)**

5. Use your calculator to work out the value of  $\sqrt{20.25} + 1.65^2$

Write down all the figures on your calculator display.

$\dots\dots\dots$

**Q5**

**(Total 2 marks)**



<p><b>6.</b> The cost of 1.5 kg of peaches is £0.84</p> <p>The total cost of 3 kg of peaches and 2 kg of apples is £2.34</p> <p>Work out the cost of 1 kg of apples.</p> <p style="text-align: right; margin-top: 20px;">.....</p> <p style="text-align: right;"><b>(Total 3 marks)</b></p>	<p>Leave blank</p> <p style="margin-top: 20px;"><b>Q6</b></p> <input style="width: 20px; height: 20px;" type="text"/>												
<p><b>7.</b> Solve <math>4y + 3 = 2y + 9</math></p> <p style="text-align: right; margin-top: 20px;"><math>y =</math> .....</p> <p style="text-align: right;"><b>(Total 2 marks)</b></p>	<p><b>Q7</b></p> <input style="width: 20px; height: 20px;" type="text"/>												
<p><b>8.</b> The table shows some expressions. In each expression, <math>n</math> is a whole number.</p> <table border="1" style="margin: 10px auto; border-collapse: collapse; text-align: center;"> <tr> <td style="padding: 5px;"><math>3n^2</math></td> <td style="padding: 5px;"><math>9n</math></td> <td style="padding: 5px;"><math>3 \times 6n</math></td> <td style="padding: 5px;"><math>3 + 6n</math></td> <td style="padding: 5px;"><math>(3n)^2</math></td> <td style="padding: 5px;"><math>n + 9</math></td> </tr> <tr> <td style="height: 20px;"></td> <td></td> <td></td> <td></td> <td></td> <td></td> </tr> </table> <p>Tick ( ✓ ) the box underneath each of the <b>three</b> expressions which are always multiples of 9</p> <p style="text-align: right;"><b>(Total 3 marks)</b></p>	$3n^2$	$9n$	$3 \times 6n$	$3 + 6n$	$(3n)^2$	$n + 9$							<p><b>Q8</b></p> <input style="width: 20px; height: 20px;" type="text"/>
$3n^2$	$9n$	$3 \times 6n$	$3 + 6n$	$(3n)^2$	$n + 9$								



Leave blank

9.

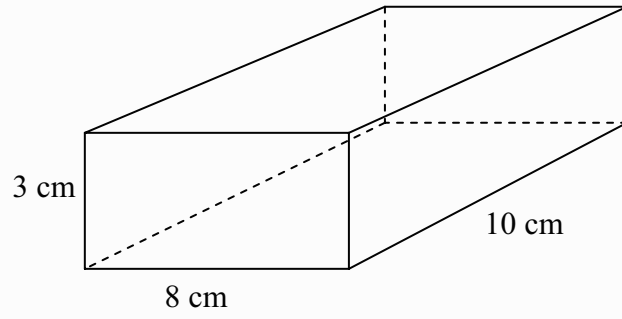

Diagram **NOT** accurately drawn

The diagram shows a solid cuboid.

Work out the total surface area of the cuboid.

..... cm<sup>2</sup>

(Total 3 marks)

Q9

10. Change 12 cm<sup>2</sup> to mm<sup>2</sup>.

..... mm<sup>2</sup>

(Total 2 marks)

Q10

11. On July 1st 2004, Jack invested £2000 at 5% per annum compound interest.

Work out the value of Jack's investment on July 1st 2006

£ .....

(Total 3 marks)

Q11



12. Ali found out the number of rooms in each of 40 houses in a town. He used the information to complete the frequency table.

Number of Rooms	Frequency	
4	4	
5	7	
6	10	
7	12	
8	5	
9	2	

Ali said that the mode is 9  
Ali is wrong.

- (a) Explain why.

.....  
.....

(1)

- (b) Beccy found out the number of rooms in each of 80 houses in the same town. She used the information to complete the frequency table below.

Number of Rooms	Frequency
4	10
5	12
6	15
7	18
8	17
9	8

Find the median number of rooms.

.....

(1)





<p>(c) The median number of rooms in Ali's table is 6</p> <p>Which of the two medians, Ali's or Beccy's, is more likely to give the more reliable estimate for the median number of rooms for a house in this town?</p> <p>.....</p> <p>Give a reason for your answer.</p> <p>.....</p> <p>.....</p> <p style="text-align: right;"><b>(1)</b></p> <p style="text-align: right;"><b>(Total 3 marks)</b></p>	<p>Leave blank</p> <p><b>Q12</b></p> <input type="text"/>
<p><b>13. (i)</b> Factorise <math>x^2 - 7x + 10</math></p> <p>.....</p> <p><b>(ii)</b> Solve <math>x^2 - 7x + 10 = 0</math></p> <p>.....</p> <p>.....</p> <p style="text-align: right;"><b>(Total 3 marks)</b></p>	<p><b>Q13</b></p> <input type="text"/>



Leave blank

14. (a) Complete the table of values for  $y = 2x^2 - 4x$

$x$	-2	-1	0	1	2	3
$y$	16		0			6

(2)

(b) On the grid, draw the graph of  $y = 2x^2 - 4x$  for values of  $x$  from -2 to 3

(2)

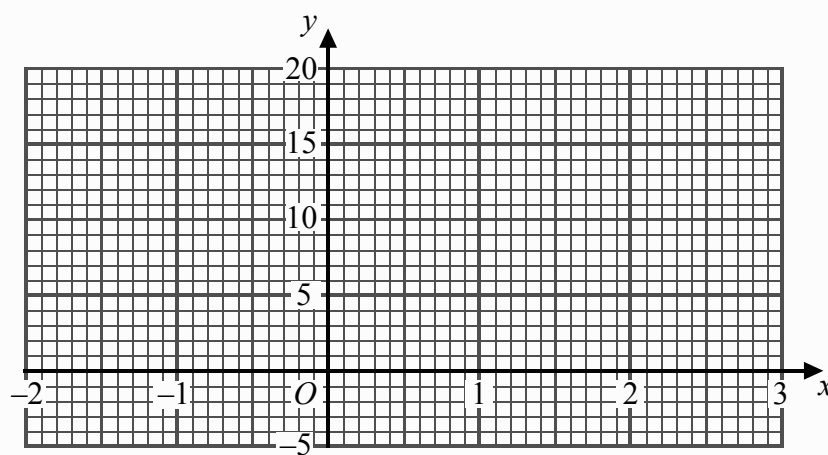

(c) (i) On the same axes, draw the straight line  $y = 2.5$

(ii) Write down the values of  $x$  for which  $2x^2 - 4x = 2.5$

.....  
(2)

Q14

(Total 6 marks)



Leave  
blank

15.

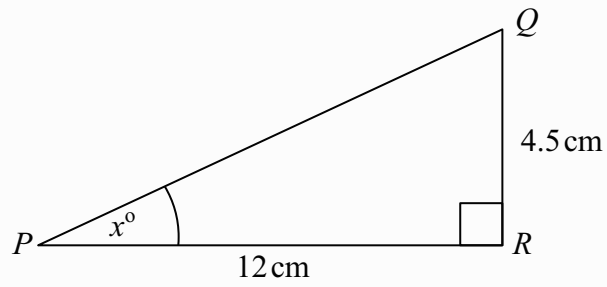

Diagram **NOT**  
accurately drawn

$PQR$  is a right-angled triangle.  
 $PR = 12$  cm.  
 $QR = 4.5$  cm.  
Angle  $PRQ = 90^\circ$ .

Work out the value of  $x$ .  
Give your answer correct to one decimal place.

$x = \dots\dots\dots$

Q15

(Total 3 marks)



Leave  
blank

16.

Month	Jan	Feb	Mar	Apr	May	Jun
Number of Televisions	1240	1270	1330	1300	1330	$x$

The table shows the number of televisions sold in a shop in the first five months of 2006.

(a) Work out the first 3-month moving average for the information in the table.

.....  
(2)

The fourth 3-month moving average of the number of televisions sold in 2006 is 1350  
The number of televisions sold in the shop in June was  $x$ .

(b) Work out the value of  $x$ .

$x =$  .....  
(2)

(Total 4 marks)

Q16

17. In a sale, normal prices are reduced by 25%.  
The sale price of a saw is £12.75

Calculate the normal price of the saw.

£ .....

(Total 3 marks)

Q17



18. Solve

$$3x + y = 8$$

$$4x + 2y = 9$$

$$x = \dots\dots\dots$$

$$y = \dots\dots\dots$$

(Total 3 marks)

Leave  
blank

Q18



19.

Diagram NOT accurately drawn

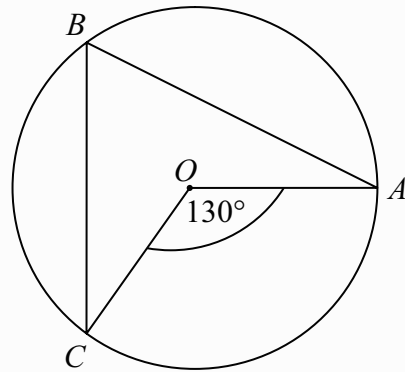

In the diagram,  $O$  is the centre of the circle.  
 $A$ ,  $B$  and  $C$  are points on the circle.

Angle  $COA = 130^\circ$ .

(i) Find the size of angle  $CBA$ .

.....<sup>o</sup>

(ii) Give a reason for your answer.

.....  
.....

Q19

(Total 2 marks)

TOTAL FOR PAPER: 62 MARKS

END



**BLANK PAGE**



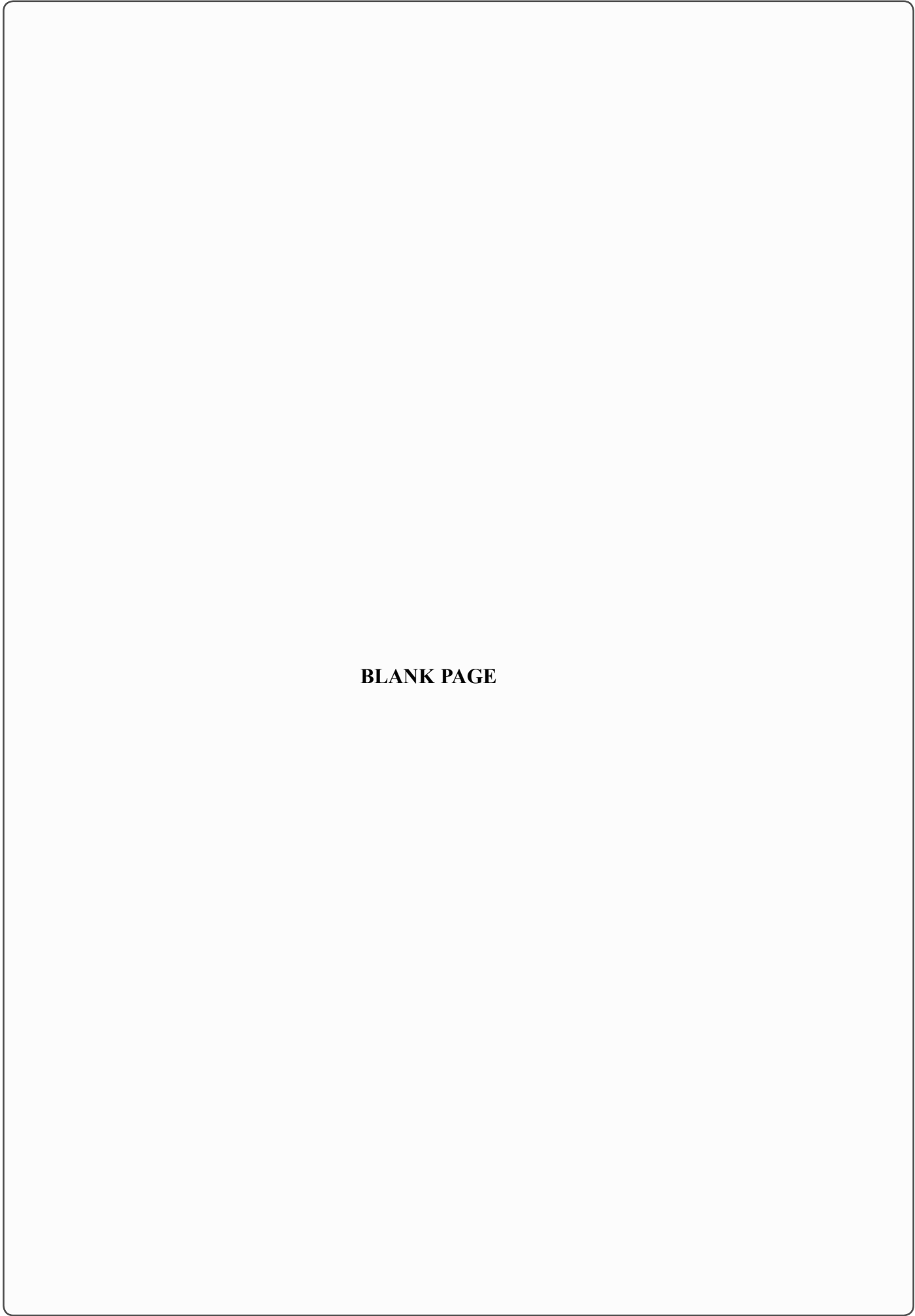

**BLANK PAGE**

