

Centre No.						Paper Reference					Surname	Initial(s)		
Candidate No.						5	5	3	6	/	1	6	Signature	

Paper Reference(s)

**5536/16**

**Edexcel GCSE**

**Mathematics B – 1388**

**Paper 16 (Non-Calculator)**



Examiner's use only

--	--	--

Team Leader's use only

--	--	--



ND001043507

**Intermediate Tier**

Tuesday 7 June 2005 – Afternoon

Time: 1 hour 15 minutes

**Materials required for examination**

Ruler graduated in centimetres and millimetres, protractor, compasses, pen, HB pencil, eraser.  
Tracing paper may be used.

**Items included with question papers**

Nil

**Instructions to Candidates**

In the boxes above, write your centre number, candidate number, your surname, initials and signature. Check that you have the correct question paper.

Answer **ALL** the questions in the spaces provided in this question paper.

**You must NOT write on the formulae page. Anything you write on the formulae page will gain NO credit.**

If you need more space to complete your answer to any question, use additional answer sheets.

**Information for Candidates**

There are 19 questions in this question paper. The total mark for this paper is 62.

The marks for individual questions and the parts of questions are shown in round brackets: e.g. (2).

**Calculators must not be used.**

**Advice to Candidates**

Show all stages in any calculations.

Work steadily through the paper. Do not spend too long on one question.

If you cannot answer a question, leave it and attempt the next one.

Return at the end to those you have left out.

This publication may be reproduced only in accordance with Edexcel Limited copyright policy.  
©2005 Edexcel Limited.

Printer's Log No.

**N21062A**

W850/R5516/57570 6/6/6/6/6/



N 2 1 0 6 2 A 0 1 1 6

*Turn over*

**edexcel**

GCSE Mathematics 1387/8

Formulae: Intermediate Tier

**You must not write on this page.  
Anything you write on this page will gain NO credit**

**Area of trapezium** =  $\frac{1}{2}(a+b)h$

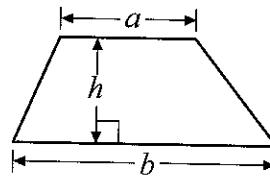

**Volume of prism** = area of cross section  $\times$  length

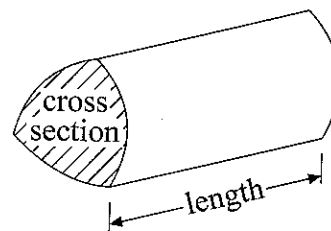

Answer ALL NINETEEN questions.

Write your answers in the spaces provided.

You must write down all stages in your working.

You must NOT use a calculator.

1. On the grid, enlarge the shape with a scale factor of 2.

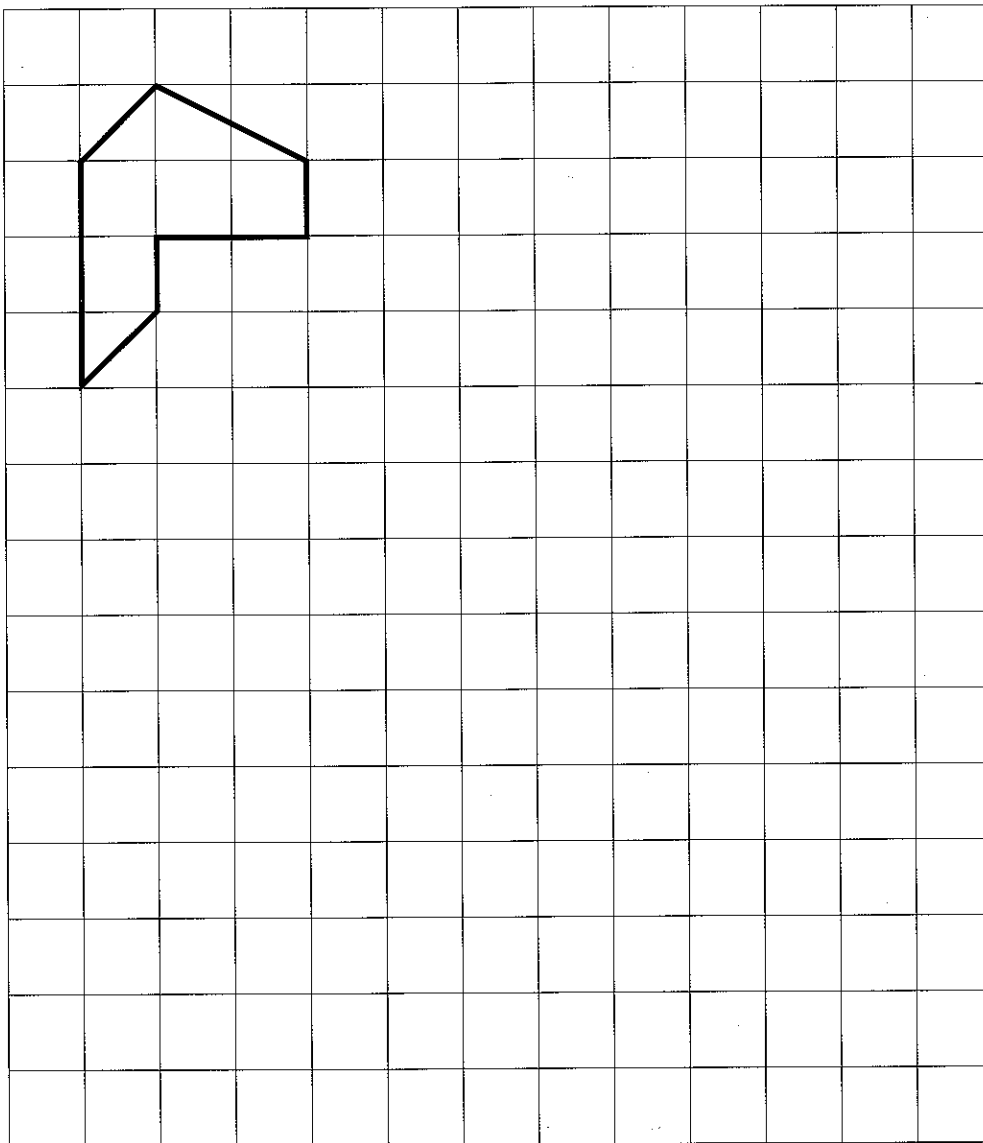

Q1

(Total 2 marks)



2. (a) Simplify  $3y^2 - y^2$

.....  
(1)

(b) Simplify  $5c + 7d - 2c - 3d$

.....  
(2)

(Total 3 marks)

Q2

3. The diagram shows a 5-sided shape.  
All the sides of the shape are equal in length.

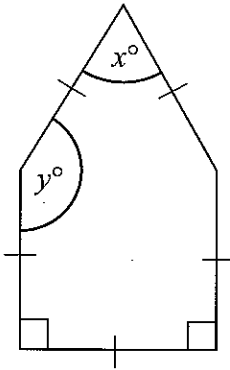

Diagram NOT accurately drawn

- (a) (i) Find the value of  $x$ .

$x =$  .....

- (ii) Give a reason for your answer.

.....  
(2)

- (b) Work out the value of  $y$ .

$y =$  .....  
(2)

(Total 4 marks)

Q3



4. The cost of a calculator is £6.79

Work out the cost of 28 of these calculators.

£ .....

(Total 3 marks)

Q4



5. The scatter graph shows some information about six new-born baby apes. For each baby ape, it shows the mother's leg length and the baby ape's birth weight.

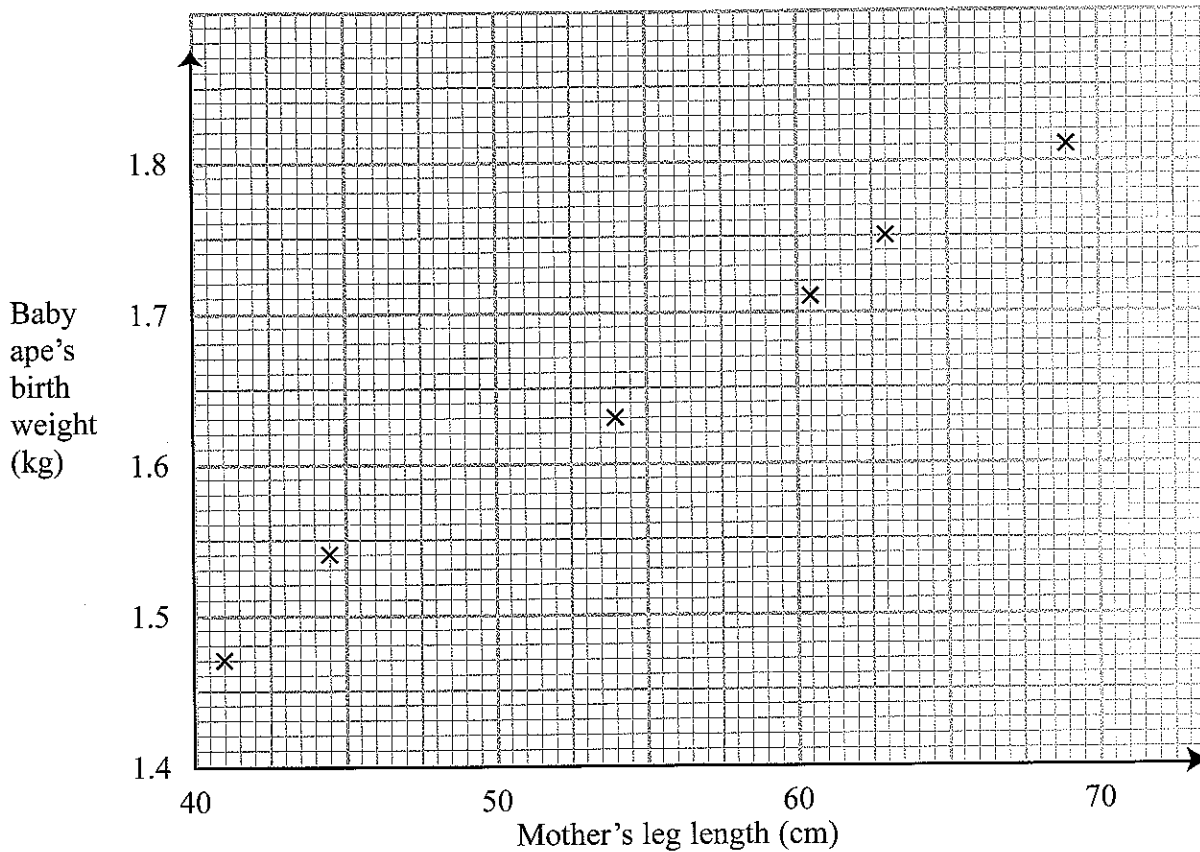

The table shows the mother's leg length and the birth weight of two more baby apes.

Mother's leg length (cm)	50	65
Baby ape's birth weight (kg)	1.6	1.75

- (a) On the scatter graph, plot the information from the table. (1)
- (b) Describe the **correlation** between a mother's leg length and her baby ape's birth weight.  
 ..... (1)
- (c) Draw a line of best fit on the diagram. (1)

A mother's leg length is 55 cm.

- (d) Use your line of best fit to estimate the birth weight of her baby ape.

..... kg  
(1)

(Total 4 marks)

Q5



6. Here are the ingredients needed to make 500 ml of custard.

**Custard**  
**makes 500 ml**  
400 ml of milk  
3 large egg yolks  
50 g sugar  
2 teaspoons of cornflour

(a) Work out the amount of sugar needed to make 2000 ml of custard.

..... g  
(2)

(b) Work out the amount of milk needed to make 750 ml of custard.

..... ml  
(2)

(Total 4 marks)

Q6



7. Here are the plan, front elevation and side elevation of a 3-D shape.

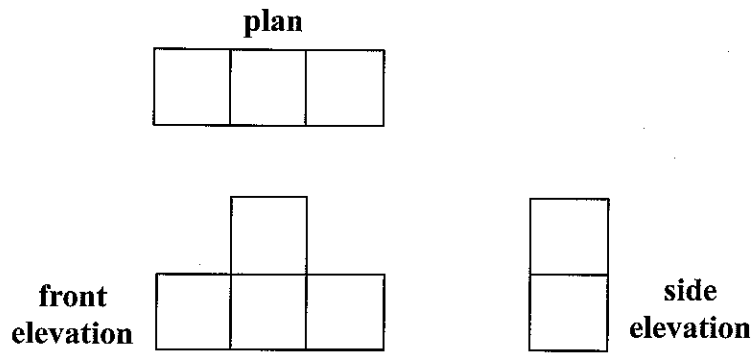

In the space below, draw a sketch of the 3-D shape.

Q7

(Total 2 marks)





8. Work out an estimate for the value of  $\frac{637}{3.2 \times 9.8}$

.....

Q8

(Total 2 marks)

9. (a) Write as a power of 5

(i)  $5^4 \times 5^2$

.....

(ii)  $5^9 \div 5^6$

.....

(2)

(b)  $2^x \times 2^y = 2^{10}$

and

$2^x \div 2^y = 2^4$

Work out the value of  $x$  and the value of  $y$ .

$x = \dots\dots\dots$

$y = \dots\dots\dots$

(3)

(Total 5 marks)

Q9



10. (a) Solve  $5 - 3x = 2(x + 1)$

$x = \dots\dots\dots$   
(3)

(b)  $-3 \leq y < 3$   
 $y$  is an integer.

Write down all the possible values of  $y$ .

$\dots\dots\dots$   
(2)

(Total 5 marks)

Q10

11. Work out the value of  $\frac{2}{3} \times \frac{3}{4}$

Give your answer as a fraction in its simplest form.

$\dots\dots\dots$

(Total 2 marks)

Q11



12.

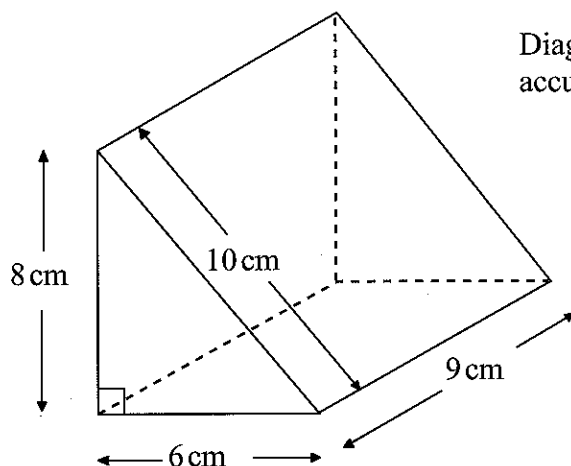

Diagram NOT accurately drawn

Work out the surface area of the triangular prism.  
State the units with your answer.

.....

Q12

(Total 4 marks)

13. The table shows some expressions.  
 $a$ ,  $b$ ,  $c$  and  $d$  represent lengths.  
 $\pi$  and 3 are numbers which have no dimensions.

$3a^2$	$\frac{\pi ab^3}{3d}$	$\pi bc$	$ac + bd$	$\pi(a + b)$	$3(c + d)^3$	$3\pi bc^2$
<input type="checkbox"/>	<input type="checkbox"/>	<input type="checkbox"/>	<input type="checkbox"/>	<input type="checkbox"/>	<input type="checkbox"/>	<input type="checkbox"/>

Tick (✓) the boxes underneath the **three** expressions which could represent volumes.

Q13

(Total 3 marks)



14. Here is a 4-sided spinner.

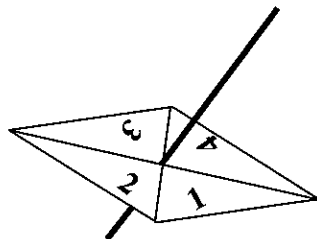

The sides of the spinner are labelled 1, 2, 3 and 4.

The spinner is biased.

The probability that the spinner will land on each of the numbers 2 and 3 is given in the table.

The probability that the spinner will land on 1 is equal to the probability that it will land on 4.

Number	1	2	3	4
Probability	$x$	0.3	0.2	$x$

(a) Work out the value of  $x$ .

$x = \dots\dots\dots$   
(2)

Sarah is going to spin the spinner 200 times.

(b) Work out an estimate for the number of times it will land on 2

$\dots\dots\dots$   
(2)

(Total 4 marks)

Q14



15. (a) Complete this table of values for  $y = x^3 + x - 2$

$x$	-2	-1	0	1	2
$y$	-12			0	

(3)

(b) On the grid, draw the graph of  $y = x^3 + x - 2$

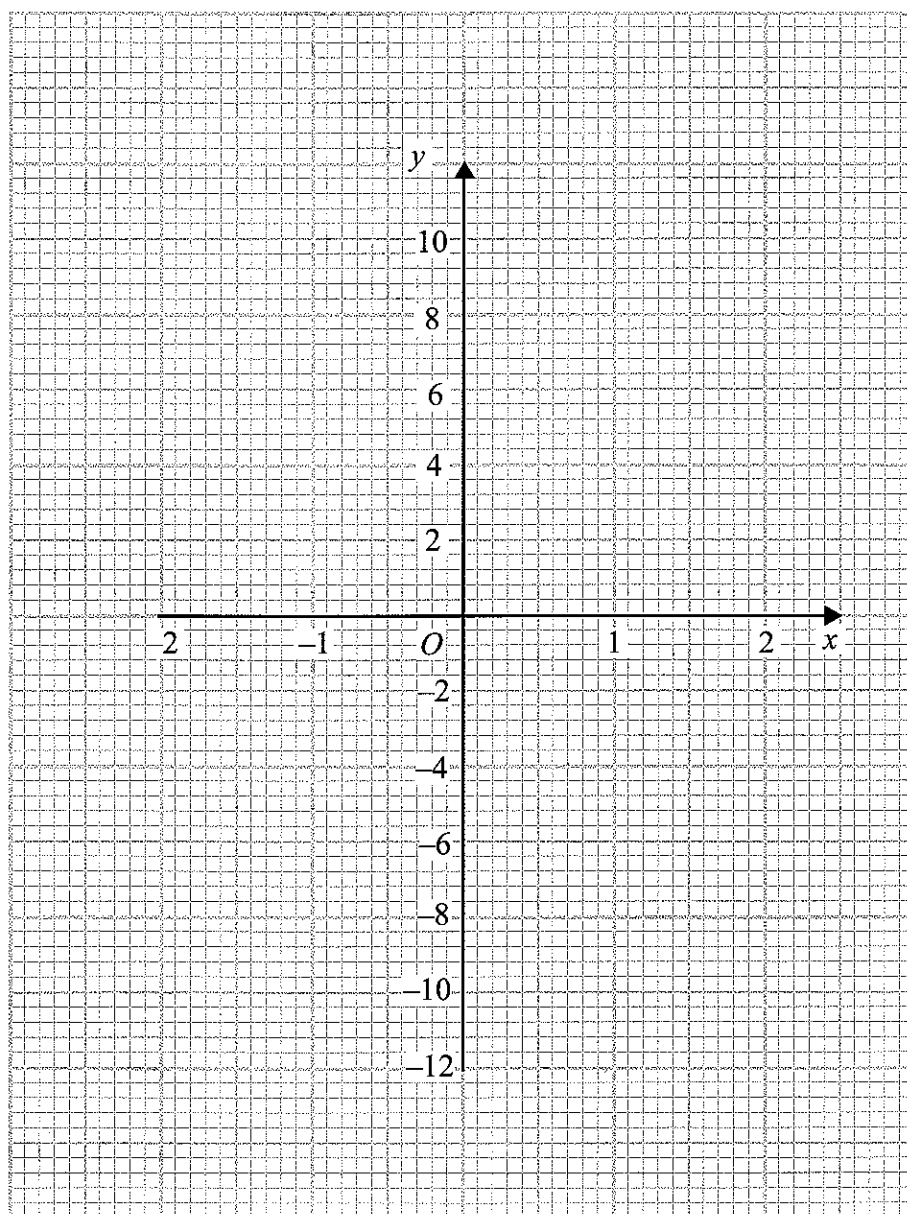

(2)

Q15

(Total 5 marks)



16. Amy is going to play one game of snooker and one game of billiards.

The probability that she will win the game of snooker is  $\frac{3}{4}$

The probability that she will win the game of billiards is  $\frac{1}{3}$

(a) Complete the probability tree diagram.

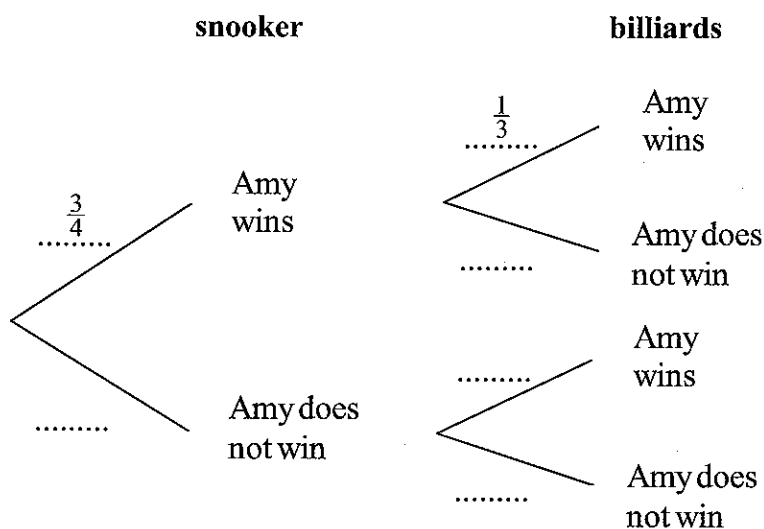

Q16

(Total 2 marks)

17. The number 40 can be written as  $2^m \times n$ , where  $m$  and  $n$  are prime numbers.

Find the value of  $m$  and the value of  $n$ .

$m =$  .....

$n =$  .....

Q17

(Total 2 marks)



18.

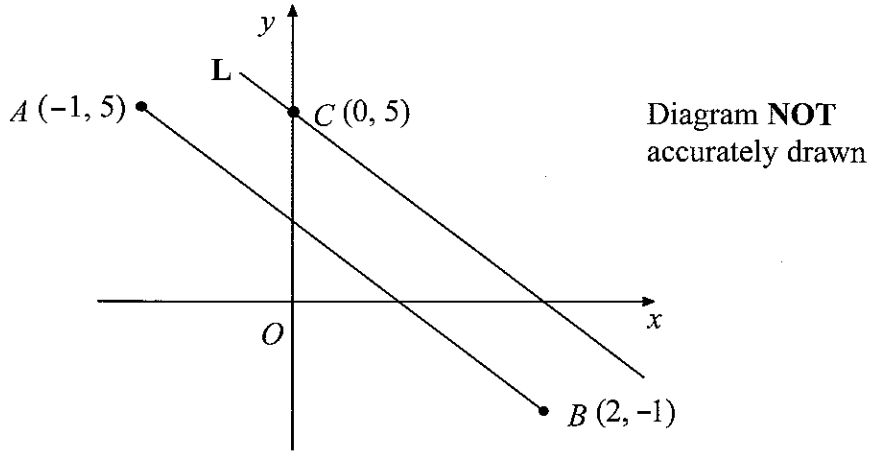

The diagram shows three points  $A(-1, 5)$ ,  $B(2, -1)$  and  $C(0, 5)$ .  
The line  $L$  is parallel to  $AB$  and passes through  $C$ .

Find the equation of the line  $L$ .

.....

(Total 4 marks)

Q18



19.

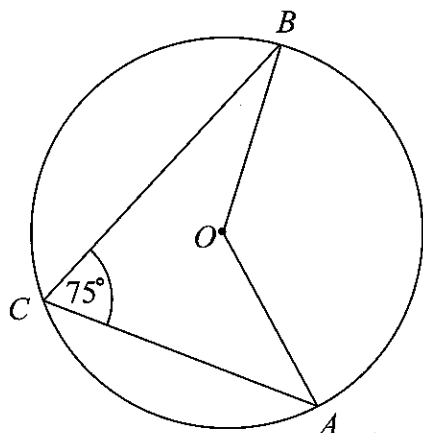

Diagram **NOT** accurately drawn

In the diagram,  $A$ ,  $B$  and  $C$  are points on the circumference of a circle, centre  $O$ .  
 Angle  $ACB = 75^\circ$ .

(i) Work out the size of angle  $AOB$ .

.....  
 °

(ii) Give a reason for your answer.

.....  
 .....

(Total 2 marks)

Q19

**TOTAL FOR PAPER: 62 MARKS**

**END**

