

Centre No.						Paper Reference					Surname	Initial(s)		
Candidate No.						5	5	2	5	/	0	5	Signature	

Paper Reference(s)
5525/05

Edexcel GCSE

Mathematics A – 1387

Paper 5 (Non-Calculator)

Higher Tier

Tuesday 7 June 2005 – Afternoon

Time: 2 hours

Examiner's use only

--	--	--

Team Leader's use only

--	--	--



NC000249267

Materials required for examination

Ruler graduated in centimetres and millimetres, protractor, compasses, pen, HB pencil, eraser.
Tracing paper may be used.

Items included with question papers

Nil

Instructions to Candidates

In the boxes above, write your centre number, candidate number, your surname, initials and signature. Check that you have the correct question paper.

Answer **ALL** the questions in the spaces provided in this question paper.

You must NOT write on the formulae page. Anything you write on the formulae page will gain NO credit.

If you need more space to complete your answer to any question, use additional answer sheets.

Information for Candidates

There are 22 questions in this paper. The total mark for this paper is 100.

The marks for individual questions and the parts of questions are shown in round brackets: e.g. (2).

Calculators must not be used

Advice to Candidates

Show all stages in any calculations.

Work steadily through the paper. Do not spend too long on one question.

If you cannot answer a question, leave it and attempt the next one.

Return at the end to those you have left out.

This publication may be reproduced only in accordance with Edexcel Limited copyright policy. ©2005 Edexcel Limited.

Printer's Log No.

N20835A

W850/R5505/57570 6/6/6/6/6/



N 2 0 8 3 5 A 0 1 2 0

Turn over

edexcel

GCSE Mathematics 1387/8

Formulae: Higher Tier

You must not write on this formulae page.
Anything you write on this formulae page will gain NO credit.

Volume of a prism = area of cross section \times length

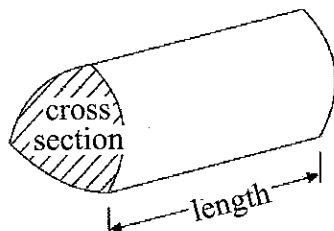

Volume of sphere = $\frac{4}{3} \pi r^3$

Surface area of sphere = $4\pi r^2$

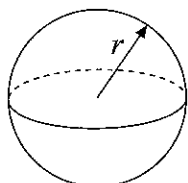

Volume of cone = $\frac{1}{3} \pi r^2 h$

Curved surface area of cone = $\pi r l$

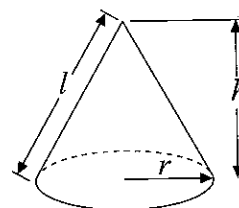

In any triangle ABC

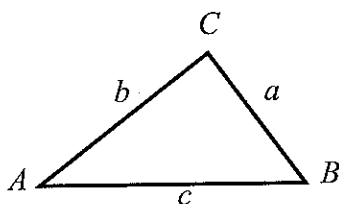

Sine Rule $\frac{a}{\sin A} = \frac{b}{\sin B} = \frac{c}{\sin C}$

Cosine Rule $a^2 = b^2 + c^2 - 2bc \cos A$

Area of triangle = $\frac{1}{2} ab \sin C$

The Quadratic Equation

The solutions of $ax^2 + bx + c = 0$
where $a \neq 0$, are given by

$$x = \frac{-b \pm \sqrt{b^2 - 4ac}}{2a}$$



Answer ALL TWENTY TWO questions.

Write your answers in the spaces provided.

You must write down all stages in your working.

You must NOT use a calculator.

1. (a) Expand and simplify $(x + 7)(x - 4)$

.....
(2)

(b) Expand $y(y^3 + 2y)$

.....
(2)

(c) Factorise $p^2 + 6p$

.....
(2)

(d) Factorise completely $6x^2 - 9xy$

.....
(2)

(Total 8 marks)

Q1

2. Janie wants to collect information about the amount of sleep the students in her class get.

Design a suitable question she could use.

(Total 2 marks)

Q2



3.

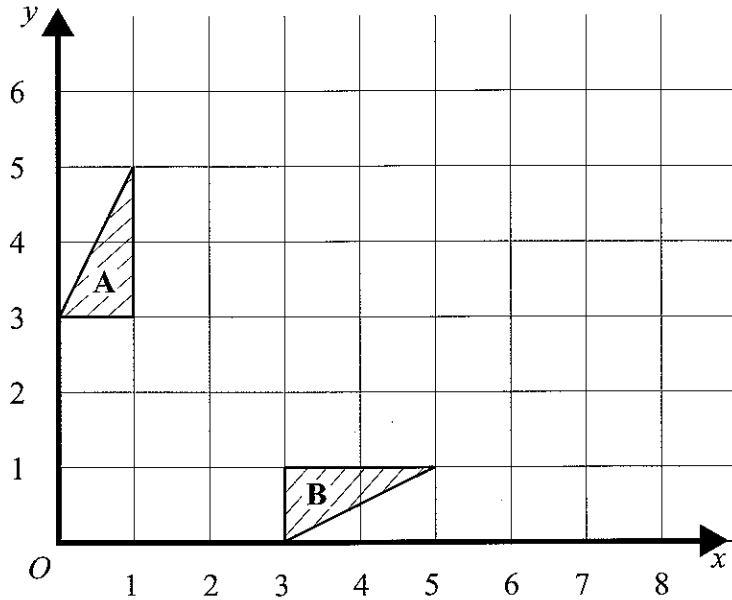

Triangle **A** and triangle **B** have been drawn on the grid.

Describe fully the single transformation which will map triangle **A** onto triangle **B**.

.....

(Total 2 marks)

Q3

4. (a) Solve $5 - 3x = 2(x+1)$

$x = \dots\dots\dots$
(3)

(b) $-3 \leq y < 3$
 y is an integer.

Write down all the possible values of y .

.....
(2)

(Total 5 marks)

Q4



5. (a) Work out the value of $\frac{2}{3} \times \frac{3}{4}$

Give your answer as a fraction in its simplest form.

.....
(2)

(b) Work out the value of $1\frac{2}{3} + 2\frac{3}{4}$

Give your answer as a fraction in its simplest form.

.....
(3)

(Total 5 marks)

Q5

6. (a) Write as a power of 5

(i) $5^4 \times 5^2$

.....

(ii) $5^9 \div 5^6$

.....
(2)

(b) $2^x \times 2^y = 2^{10}$

and

$2^x \div 2^y = 2^4$

Work out the value of x and the value of y .

$x =$

$y =$

(3)

(Total 5 marks)

Q6



7.

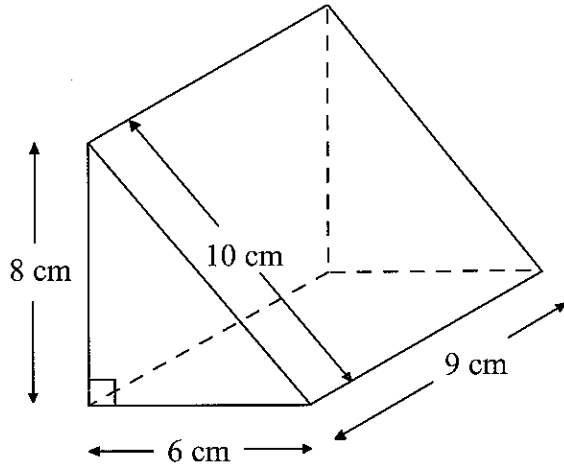

Diagram **NOT** accurately drawn

Work out the surface area of the triangular prism.
State the units with your answer.

.....

(Total 4 marks)

Q7

8. The table shows some expressions.
 a , b , c and d represent lengths.
 π and 3 are numbers which have no dimensions.

$3a^2$	$\frac{\pi ab^3}{3d}$	πbc	$ac+bd$	$\pi(a+b)$	$3(c+d)^3$	$3\pi bc^2$
<input type="checkbox"/>	<input type="checkbox"/>	<input type="checkbox"/>	<input type="checkbox"/>	<input type="checkbox"/>	<input type="checkbox"/>	<input type="checkbox"/>

Tick (✓) the boxes underneath the **three** expressions which could represent volumes.

(Total 3 marks)

Q8



9. Here is a 4-sided spinner.

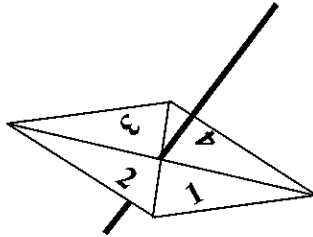

The sides of the spinner are labelled 1, 2, 3 and 4.

The spinner is biased.

The probability that the spinner will land on each of the numbers 2 and 3 is given in the table.

The probability that the spinner will land on 1 is equal to the probability that it will land on 4.

Number	1	2	3	4
Probability	x	0.3	0.2	x

(a) Work out the value of x .

$x = \dots\dots\dots$
(2)

Sarah is going to spin the spinner 200 times.

(b) Work out an estimate for the number of times it will land on 2.

$\dots\dots\dots$
(2)
(Total 4 marks)

Q9



10. (a) Complete this table of values for $y = x^3 + x - 2$

x	-2	-1	0	1	2
y	-12			0	

(3)

(b) On the grid, draw the graph of $y = x^3 + x - 2$

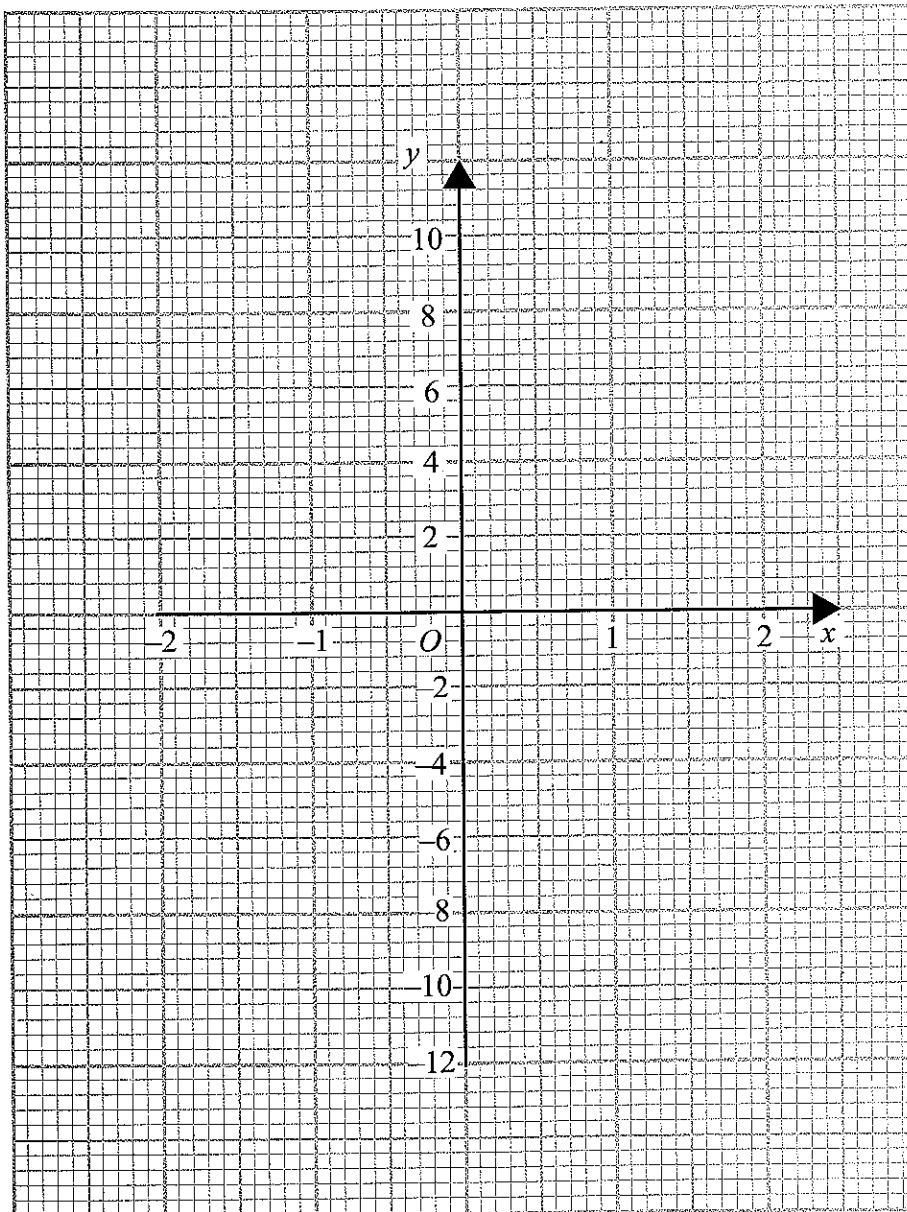

(2)

Q10

(Total 5 marks)



11. The number 40 can be written as $2^m \times n$, where m and n are prime numbers.

Find the value of m and the value of n .

$m = \dots\dots\dots$

$n = \dots\dots\dots$

(Total 2 marks)

Q11

12.

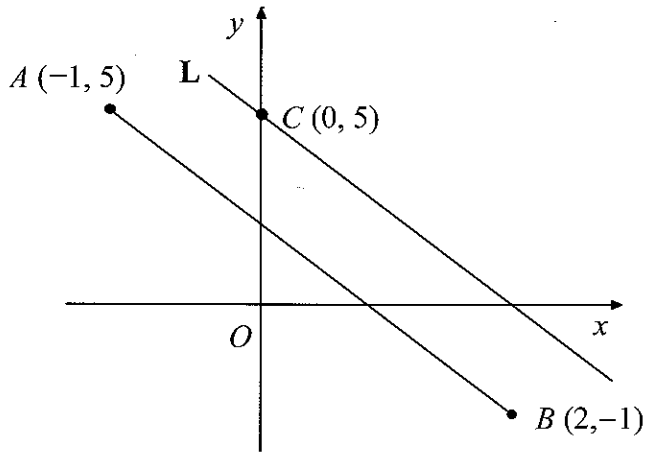

Diagram NOT accurately drawn

The diagram shows three points $A(-1, 5)$, $B(2, -1)$ and $C(0, 5)$.
The line L is parallel to AB and passes through C .

Find the equation of the line L .

.....

(Total 4 marks)

Q12



13. Amy is going to play one game of snooker and one game of billiards.
 The probability that she will win the game of snooker is $\frac{3}{4}$
 The probability that she will win the game of billiards is $\frac{1}{3}$

(a) Complete the probability tree diagram.

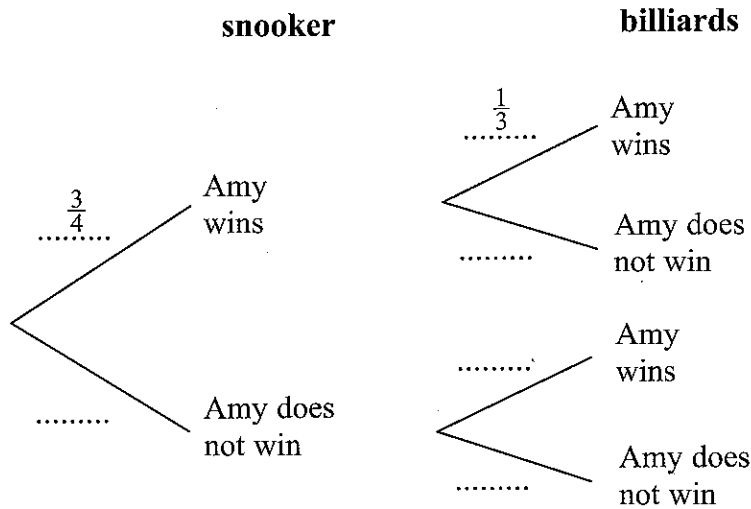

(2)

(b) Work out the probability that Amy will win **exactly** one game.

.....
(3)

Amy played one game of snooker and one game of billiards on a number of Fridays.
 She won at **both** snooker and billiards on 21 Fridays.

(c) Work out an estimate for the number of Fridays on which Amy did not win either game.

.....
(3)

(Total 8 marks)

Q13

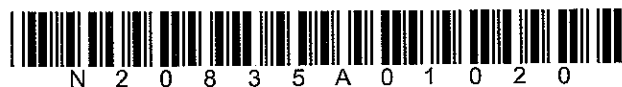

14.

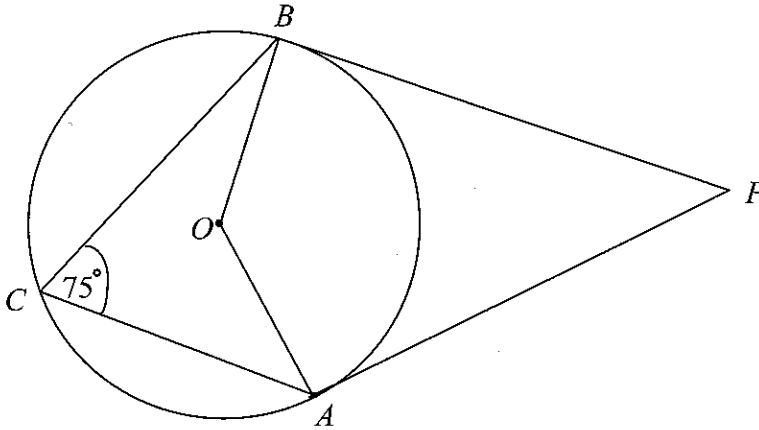

Diagram NOT accurately drawn

In the diagram, A , B and C are points on the circumference of a circle, centre O .
 PA and PB are tangents to the circle.
 Angle $ACB = 75^\circ$.

(a) (i) Work out the size of angle AOB .

.....
 °

(ii) Give a reason for your answer.

.....

 (2)

(b) Work out the size of angle APB .

.....

 (3)

(Total 5 marks)

Q14



15. (a) Change $\frac{3}{11}$ to a decimal.

.....
(1)

(b) Prove that the recurring decimal $0.\dot{3}\dot{9} = \frac{13}{33}$

.....
(3)
(Total 4 marks)

Q15

16. d is directly proportional to the square of t .
 $d = 80$ when $t = 4$

(a) Express d in terms of t .

.....
(3)

(b) Work out the value of d when $t = 7$

$d =$
(1)

(c) Work out the positive value of t when $d = 45$

$t =$
(2)

(Total 6 marks)

Q16



17. Here is a sketch of the graph of $y = 25 - \frac{(x-8)^2}{4}$ for $0 \leq x \leq 12$

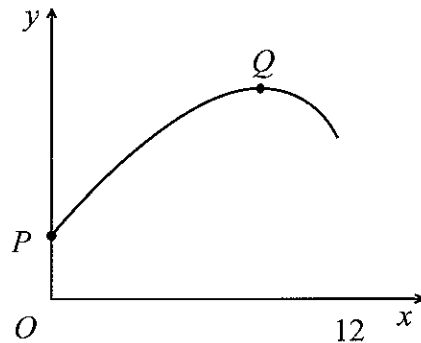

P and Q are points on the graph.
 P is the point at which the graph meets the y -axis.
 Q is the point at which y has its maximum value.

(a) Find the coordinates of

(i) P ,

(.....,.....)

(ii) Q .

(.....,.....)

(3)

(b) Show that $25 - \frac{(x-8)^2}{4} = \frac{(2+x)(18-x)}{4}$

(3)

Q17

(Total 6 marks)



18.

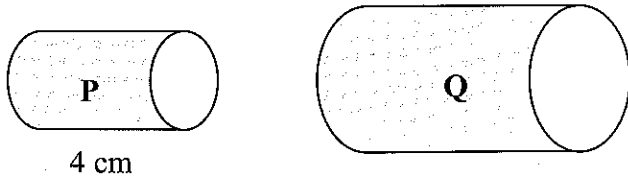

Diagram NOT accurately drawn

Two cylinders, **P** and **Q**, are mathematically similar.
 The total surface area of cylinder **P** is $90\pi \text{ cm}^2$.
 The total surface area of cylinder **Q** is $810\pi \text{ cm}^2$.
 The length of cylinder **P** is 4 cm.

(a) Work out the length of cylinder **Q**.

..... cm
 (3)

The volume of cylinder **P** is $100\pi \text{ cm}^3$.

(b) Work out the volume of cylinder **Q**.
 Give your answer as a multiple of π .

..... cm^3
 (2)

(Total 5 marks)

Q18



19. (a) Find the value of

(i) 64^0

(ii) $64^{\frac{1}{2}}$

(iii) $64^{-\frac{2}{3}}$

.....

.....

.....

(4)

(b) $3 \times \sqrt{27} = 3^n$
Find the value of n .

$n = \dots\dots\dots$

(2)

(Total 6 marks)

Q19



20. Diagram 1 is a sketch of part of the graph of $y = \sin x^\circ$.

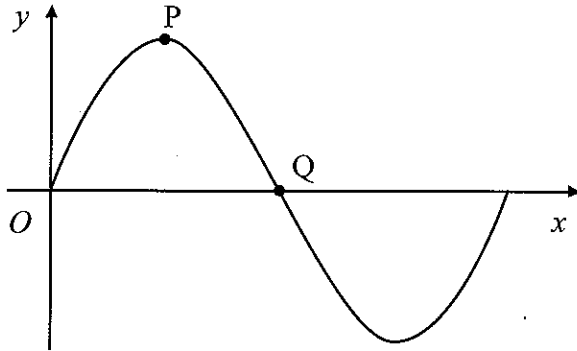

Diagram 1

(a) Write down the coordinates of

(i) P ,

(..... ,)

(ii) Q .

(..... ,)

(2)

Diagram 2 is a sketch of part of the graph of $y = 3\cos 2x^\circ$.

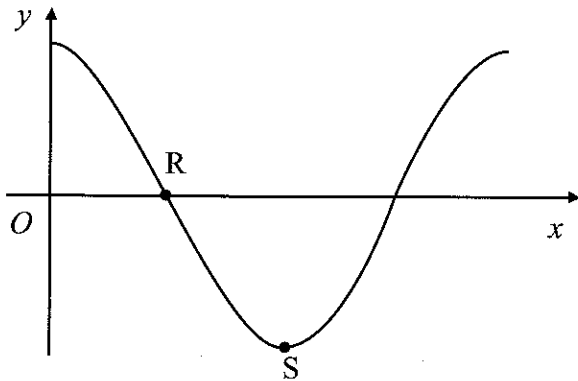

Diagram 2

(b) Write down the coordinates of

(i) R ,

(..... ,)

(ii) S .

(..... ,)

(2)

(Total 4 marks)

Q20



21.

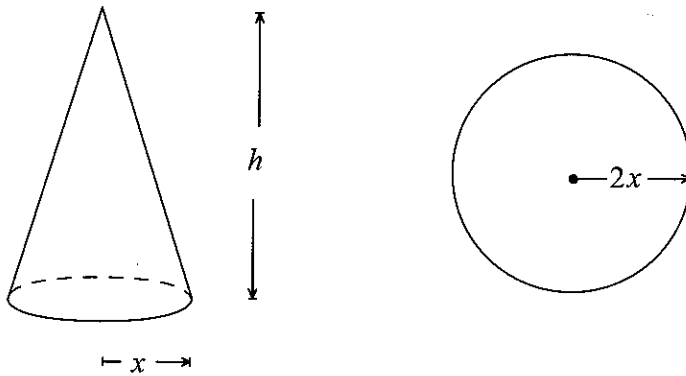

Diagram **NOT** accurately drawn

The radius of the base of a cone is x cm and its height is h cm.
 The radius of a sphere is $2x$ cm.
 The volume of the cone and the volume of the sphere are equal.

Express h in terms of x .
 Give your answer in its simplest form.

$h = \dots\dots\dots$

(Total 3 marks)

Q21



22.

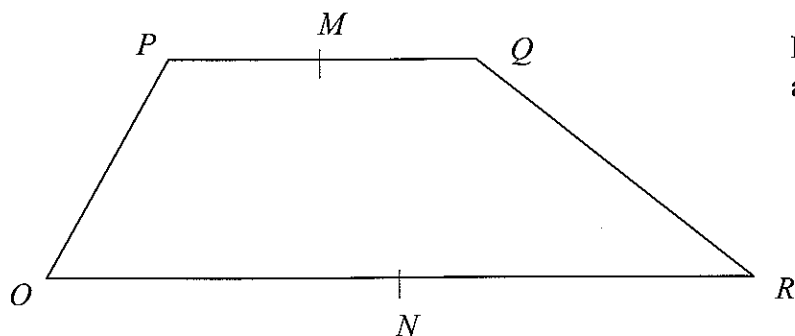

Diagram NOT accurately drawn

$OPQR$ is a trapezium with PQ parallel to OR .

$$\vec{OP} = 2\mathbf{b} \quad \vec{PQ} = 2\mathbf{a} \quad \vec{OR} = 6\mathbf{a}$$

M is the midpoint of PQ and N is the midpoint of OR .

(a) Find the vector \vec{MN} in terms of \mathbf{a} and \mathbf{b} .

$$\vec{MN} = \dots\dots\dots (2)$$

X is the midpoint of MN and Y is the midpoint of QR .

(b) Prove that XY is parallel to OR .

(2)

Q22

(Total 4 marks)

TOTAL FOR PAPER: 100 MARKS

END



BLANK PAGE

