

Centre No.					
Candidate No.					

Paper Reference (complete below)						
<b>5</b>	<b>5</b>	<b>0</b>	<b>6</b>	<b>/</b>	<b>0</b>	<b>6</b>

Surname	Initial(s)
Signature	

Paper Reference(s)

**5506/06**

# Edexcel GCSE

## Mathematics A – 1387

### Paper 6 (Calculator)

### Higher Tier

Tuesday 10 June 2003 – Morning

Time: 2 hours



Examiner's use only

--	--	--

Team Leader's use only

--	--	--

**Materials required for examination**

Ruler graduated in centimetres and millimetres, protractor, compasses, pen, HB pencil, eraser, calculator. Tracing paper may be used.

**Items included with question papers**

Formulae sheet

### **Instructions to Candidates**

In the boxes above, write your centre number, candidate number, your surname, initial(s) and your signature.

Check that you have the correct question paper.

Answer **ALL** the questions in the spaces provided in this question paper.

Supplementary answer sheets may be used.

### **Information for Candidates**

The total mark for this paper is 100.

The marks for individual questions and parts of questions are shown in round brackets: e.g. (2).

**Calculators may be used.**

If your calculator does not have a  $\pi$  button, take the value of  $\pi$  to be 3.142 unless the question instructs otherwise.

This paper has 20 questions. There are no blank pages.

### **Advice to Candidates**

Show all stages in any calculations.

Work steadily through the paper.

Do not spend too long on one question.

If you cannot answer a question, leave it and attempt the next one.

Return at the end to those you have left out.

Printer's Log. No.

**N13317A**



*Turn over*

Answer ALL TWENTY Questions.

Leave  
blank

Write your answers in the spaces provided.

You must write down all stages in your working.

1.

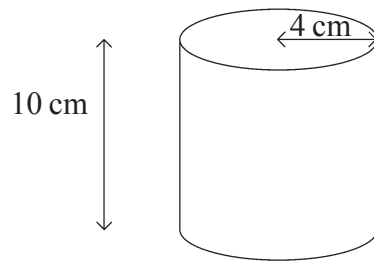

Diagram **NOT**  
accurately drawn

The diagram shows a cylinder with a height of 10 cm and a radius of 4 cm.

- (a) Calculate the volume of the cylinder.  
Give your answer correct to 3 significant figures.

.....cm<sup>3</sup>  
(2)

The length of a pencil is 13 cm.  
The pencil cannot be broken.

- (b) Show that this pencil cannot fit inside the cylinder.

(3)

*Leave blank*

2. (a) Express the following numbers as products of their prime factors.

(i) 60,

.....

(ii) 96.

.....

**(4)**

(b) Find the Highest Common Factor of 60 and 96.

.....

**(1)**

(c) Work out the Lowest Common Multiple of 60 and 96.

.....

**(2)**

**Page Total**

--	--

**Turn over**

3. A garage keeps records of the costs of repairs to its customers' cars. The table gives information about the costs of all repairs which were less than £250 in one week.

*Leave blank*

Cost, (£ $C$ )	Frequency
$0 < C \leq 50$	4
$50 < C \leq 100$	8
$100 < C \leq 150$	7
$150 < C \leq 200$	10
$200 < C \leq 250$	11

- (a) Find the class interval in which the median lies.

.....  
(2)

There was only one further repair that week, not included in the table. That repair cost £1000.

Dave says 'The class interval in which the median lies will change.'

- (b) Is Dave correct? Explain your answer.

.....  
.....  
(1)

The garage also sells cars. It offers a discount of 20% off the normal price for cash.

Dave pays £5200 cash for a car.

- (c) Calculate the normal price of the car.

£ .....  
(3)

4.

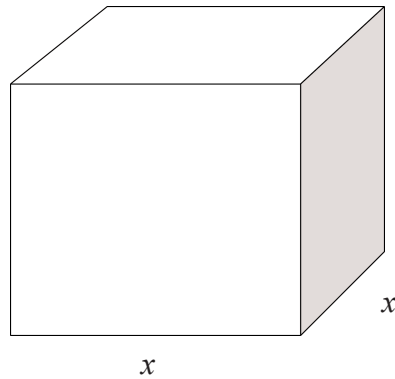

*Leave  
blank*

A cuboid has a square base of side  $x$  cm.  
The height of the cuboid is 1 cm more than the length  $x$  cm.  
The volume of the cuboid is  $230 \text{ cm}^3$ .

(a) Show that  $x^3 + x^2 = 230$

(2)

The equation  $x^3 + x^2 = 230$

has a solution between  $x = 5$  and  $x = 6$ .

(b) Use a trial and improvement method to find this solution.  
Give your answer correct to 1 decimal place.  
You must show **all** your working.

$x = \dots\dots\dots$

(4)

Page Total

--	--

Turn over

5.

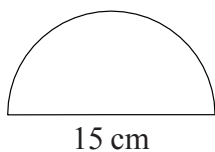

Diagram **NOT**  
accurately drawn

*Leave  
blank*

The diagram shows a semi-circle.  
The diameter of the semi-circle is 15 cm.

Calculate the area of the semi-circle.  
Give your answer correct to 3 significant figures.

.....

**(3)**

6. A straight line has equation  $y = \frac{1}{2}x + 1$

The point  $P$  lies on the straight line.  
 $P$  has a  $y$ -coordinate of 5.

(a) Find the  $x$ -coordinate of  $P$ .

.....

**(2)**

(b) Write down the equation of a different straight line that is parallel to  $y = \frac{1}{2}x + 1$

.....

**(1)**

(c) Rearrange  $y = \frac{1}{2}x + 1$  to make  $x$  the subject.

*Leave  
blank*

.....  
(2)

7. Solve

$$\begin{aligned}2x - 3y &= 11 \\5x + 2y &= 18\end{aligned}$$

$x =$  .....

$y =$  .....

(4)

Page Total

--	--

Turn over

8.

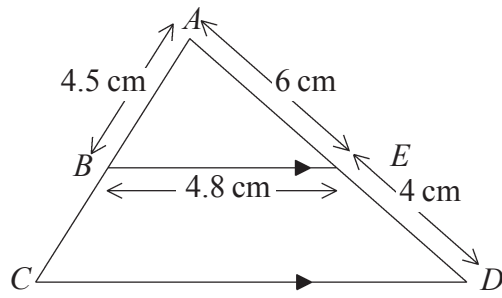

Diagram **NOT**  
accurately drawn

Leave  
blank

$BE$  is parallel to  $CD$ .  
 $AE = 6$  cm,  $ED = 4$  cm,  $AB = 4.5$  cm,  $BE = 4.8$  cm.

(a) Calculate the length of  $CD$ .

.....cm  
(2)

(b) Calculate the perimeter of the trapezium  $EBCD$ .

.....cm  
(2)



Leave blank

9.

$$y^2 = \frac{ab}{a+b}$$

$$a = 3 \times 10^8$$
$$b = 2 \times 10^7$$

Find  $y$ .

Give your answer in standard form correct to 2 significant figures.

$y = \dots\dots\dots$

(3)

10.

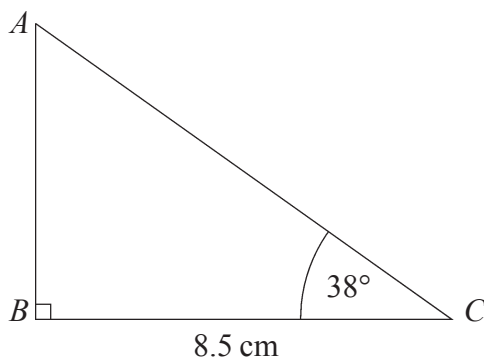

Diagram **NOT** accurately drawn

The diagram shows triangle  $ABC$ .

$BC = 8.5$  cm.

Angle  $ABC = 90^\circ$ .

Angle  $ACB = 38^\circ$ .

Work out the length of  $AB$ .

Give your answer correct to 3 significant figures.

$\dots\dots\dots$  cm

(3)

Page Total

--	--

Turn over



(c) (i) Julie throws a fair red dice once and a fair blue dice once. Calculate the probability that Julie gets a six on both the red dice and the blue dice.

*Leave blank*

.....

(ii) Calculate the probability that Julie gets at least one six.

.....

**(5)**

---

**Page Total**

--	--

**Turn over**

12.

Diagram NOT accurately drawn

Leave blank

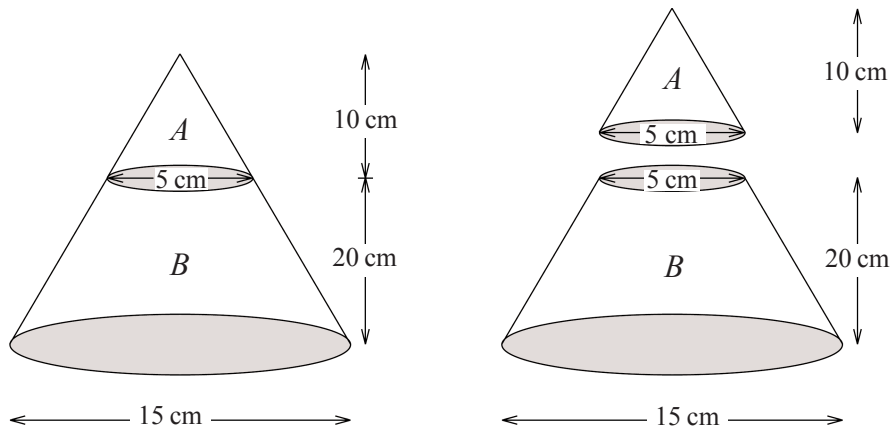

The diagram represents a large cone of height 30 cm and base diameter 15 cm.

The large cone is made by placing a small cone *A* of height 10 cm and base diameter 5 cm on top of a frustum *B*.

- (a) Calculate the volume of the frustum *B*.  
Give your answer correct to 3 significant figures.

.....cm<sup>3</sup>  
(3)

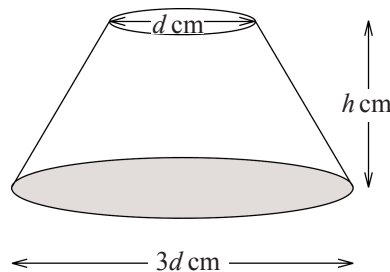

Diagram NOT accurately drawn

The diagram shows a frustum.  
The diameter of the base is  $3d$  cm and the diameter of the top is  $d$  cm.  
The height of the frustum is  $h$  cm.

The formula for the curved surface area,  $S \text{ cm}^2$ , of the frustum is

$$S = 2\pi d\sqrt{h^2 + d^2}$$

(b) Rearrange the formula to make  $h$  the subject.

$$h = \dots\dots\dots \quad (3)$$

Two mathematically similar frustums have heights of 20 cm and 30 cm.

The surface area of the smaller frustum is  $450 \text{ cm}^2$ .

(c) Calculate the surface area of the larger frustum.

$$\dots\dots\dots \text{cm}^2 \quad (2)$$

*Leave blank*

**Page Total**

--	--

**Turn over**

13.

Diagram **NOT**  
accurately drawn

*Leave  
blank*

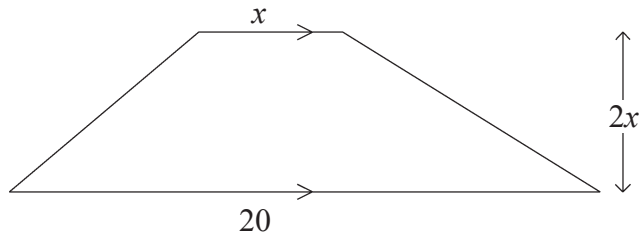

The diagram shows a trapezium.  
The measurements on the diagram are in centimetres.  
The lengths of the parallel sides are  $x$  cm and  $20$  cm.  
The height of the trapezium is  $2x$  cm.

The area of the trapezium is  $400 \text{ cm}^2$ .

(a) Show that

$$x^2 + 20x = 400$$

(2)

(b) Find the value of  $x$ .  
Give your answer correct to 3 decimal places.

.....  
(3)

14.

Diagram **NOT**  
accurately drawn

*Leave  
blank*

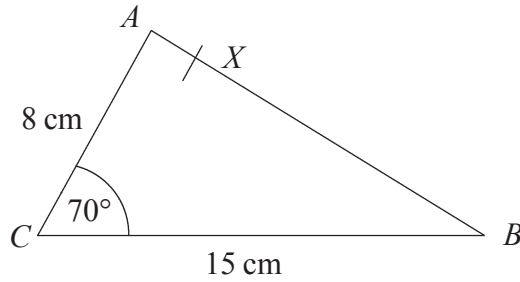

In triangle  $ABC$ ,  
 $AC = 8$  cm,  
 $CB = 15$  cm,  
Angle  $ACB = 70^\circ$ .

- (a) Calculate the area of triangle  $ABC$ .  
Give your answer correct to 3 significant figures.

.....cm<sup>2</sup>  
(2)

$X$  is the point on  $AB$  such that angle  $CXB = 90^\circ$ .

- (b) Calculate the length of  $CX$ .  
Give your answer correct to 3 significant figures.

.....cm  
(4)

Page Total

--	--

Turn over

15. (a) Show that  $(2a - 1)^2 - (2b - 1)^2 = 4(a - b)(a + b - 1)$

*Leave  
blank*

**(3)**

(b) Prove that the difference between the squares of any two odd numbers is a multiple of 8.  
(You may assume that any odd number can be written in the form  $2r - 1$ , where  $r$  is an integer).

**(3)**



16.

Leave blank

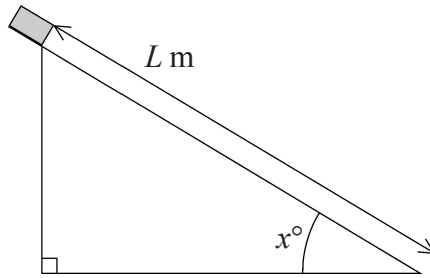

Elliot did an experiment to find the value of  $g \text{ m/s}^2$ , the acceleration due to gravity. He measured the time,  $T$  seconds, that a block took to slide  $L$  m down a smooth slope of angle  $x^\circ$ .

He then used the formula  $g = \frac{2L}{T^2 \sin x^\circ}$

to calculate an estimate for  $g$ .

- $T = 1.3$  correct to 1 decimal place.
- $L = 4.50$  correct to 2 decimal places.
- $x = 30$  correct to the nearest integer.

- (a) Calculate the lower bound and the upper bound for the value of  $g$ . Give your answers correct to 3 decimal places.

Lower bound .....

Upper bound.....

(4)

- (b) Use your answers to part (a) to write down the value of  $g$  to a suitable degree of accuracy. Explain your reasoning.

.....

.....

.....

(1)

Page Total

--	--

Turn over

17.

$$x = 2^p, \quad y = 2^q$$

*Leave  
blank*

(a) Express in terms of  $x$  and/or  $y$ ,

(i)  $2^{p+q}$

.....

(ii)  $2^{2q}$

.....

(iii)  $2^{p-1}$

.....

**(3)**

$$xy = 32$$

and

$$2xy^2 = 32$$

(b) Find the value of  $p$  and the value of  $q$ .

$$p = \text{.....}$$

$$q = \text{.....}$$

**(2)**

18. For all values of  $x$  and  $m$ ,  $x^2 - 2mx = (x - m)^2 - k$

*Leave  
blank*

(a) Express  $k$  in terms of  $m$ .

.....  
(2)

The expression  $x^2 - 2mx$  has a minimum value as  $x$  varies.

(b) (i) Find the minimum value of  $x^2 - 2mx$ .  
Give your answer in terms of  $m$ .

.....  
(ii) State the value of  $x$  for which this minimum value occurs.  
Give your answer in terms of  $m$ .  
.....  
(3)

19. The probability that Betty will be late for school tomorrow is 0.05  
The probability that Colin will be late for school tomorrow is 0.06

The probability that both Betty and Colin will be late for school tomorrow is 0.011

Fred says that the events 'Betty will be late tomorrow' and 'Colin will be late tomorrow' are independent.

Justify whether Fred is correct or not.

.....  
.....  
.....  
(2)

Page Total

--	--

Turn over

20.

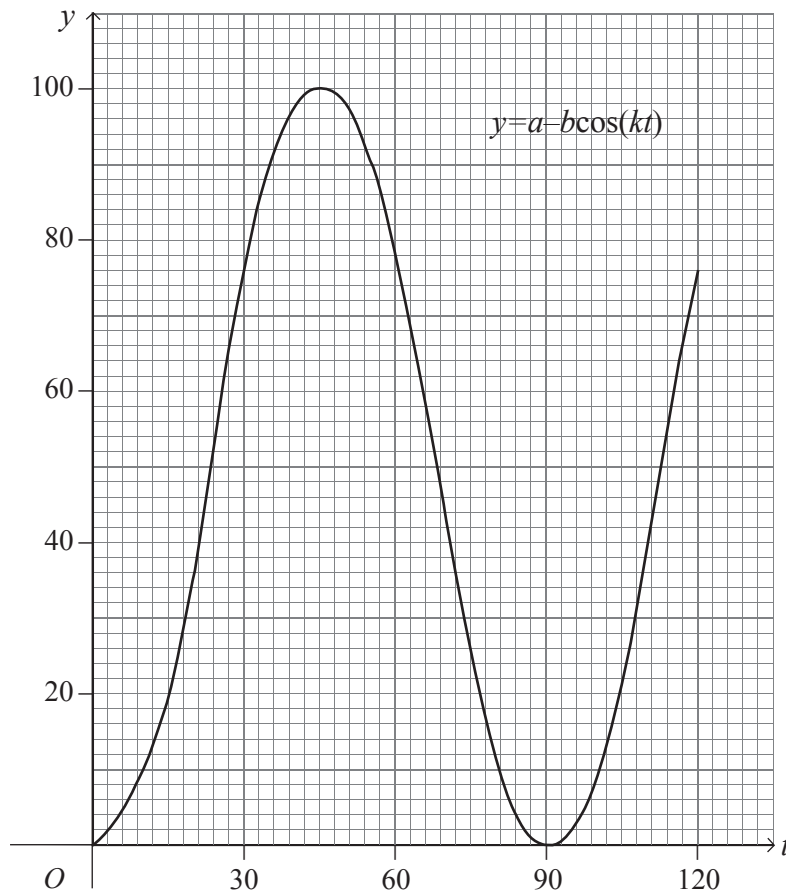

Leave  
blank

The graph of  $y = a - b \cos(kt)$ , for values of  $t$  between  $0^\circ$  and  $120^\circ$ , is drawn on the grid.

Use the graph to find an estimate for the value of

(i)  $a$ ,

.....

(ii)  $b$ ,

.....

(iii)  $k$ .

.....

(3)

**TOTAL FOR PAPER : 100 MARKS**

**END**

Page Total

--	--