



General Certificate of Secondary Education
2015

Centre Number

--	--	--	--	--

Candidate Number

--	--	--	--

Mathematics

Unit T6 Paper 1

(Non-calculator)

Higher Tier



[GMT61]

GMT61

TUESDAY 26 MAY, 1.30pm–2.45pm

TIME

1 hour 15 minutes.

INSTRUCTIONS TO CANDIDATES

Write your Centre Number and Candidate Number in the spaces provided at the top of this page.

You must answer the questions in the spaces provided.

Do not write outside the boxed area on each page, on blank pages or tracing paper.

Complete in blue or black ink only. **Do not write with a gel pen.**

Answer **all fourteen** questions.

Any working should be clearly shown in the spaces provided since marks may be awarded for partially correct solutions.

You **must not** use a calculator for this paper.

INFORMATION FOR CANDIDATES

The total mark for this paper is 50.

Figures in brackets printed down the right-hand side of pages indicate the marks awarded to each question or part question.

Functional Elements will be assessed in this paper.

Quality of written communication will be assessed in **Questions 7 and 13**.

You should have a ruler, compasses and a protractor.

The Formula Sheet is on page 2.

9469.05 R



16GMT6101

Formula Sheet

Volume of prism = area of cross section \times length

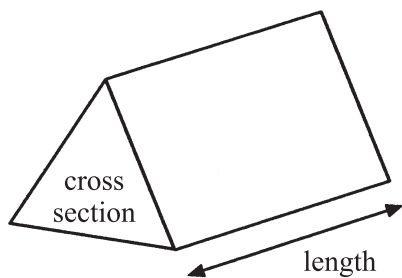

Area of trapezium = $\frac{1}{2}(a+b)h$

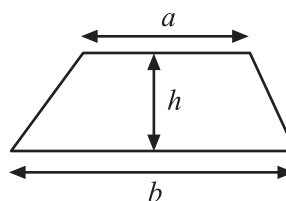

Volume of sphere = $\frac{4}{3}\pi r^3$

Surface area of sphere = $4\pi r^2$

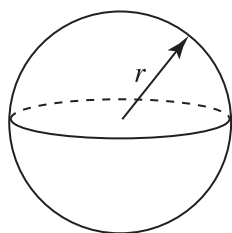

Volume of cone = $\frac{1}{3}\pi r^2 h$

Curved surface area of cone = $\pi r l$

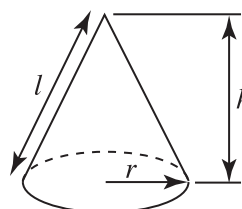

In any triangle ABC

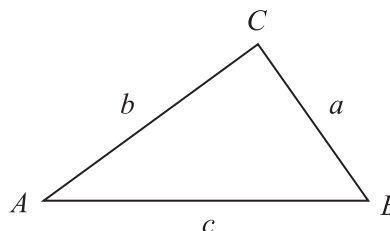

Quadratic Equation

The solutions of $ax^2 + bx + c = 0$
where $a \neq 0$, are given by

$$x = \frac{-b \pm \sqrt{b^2 - 4ac}}{2a}$$

Sine Rule: $\frac{a}{\sin A} = \frac{b}{\sin B} = \frac{c}{\sin C}$

Cosine Rule: $a^2 = b^2 + c^2 - 2bc \cos A$

Area of triangle = $\frac{1}{2} ab \sin C$



1 Given that $32.5 \times 24 = 780$, write down the value of

(a) 32.5×2.4

Answer _____ [1]

(b) $78 \div 24$

Answer _____ [1]

(c) 32.5×12

Answer _____ [1]

[Turn over



2 The graph shows a journey by coach from Bridgetown to Mayfield.

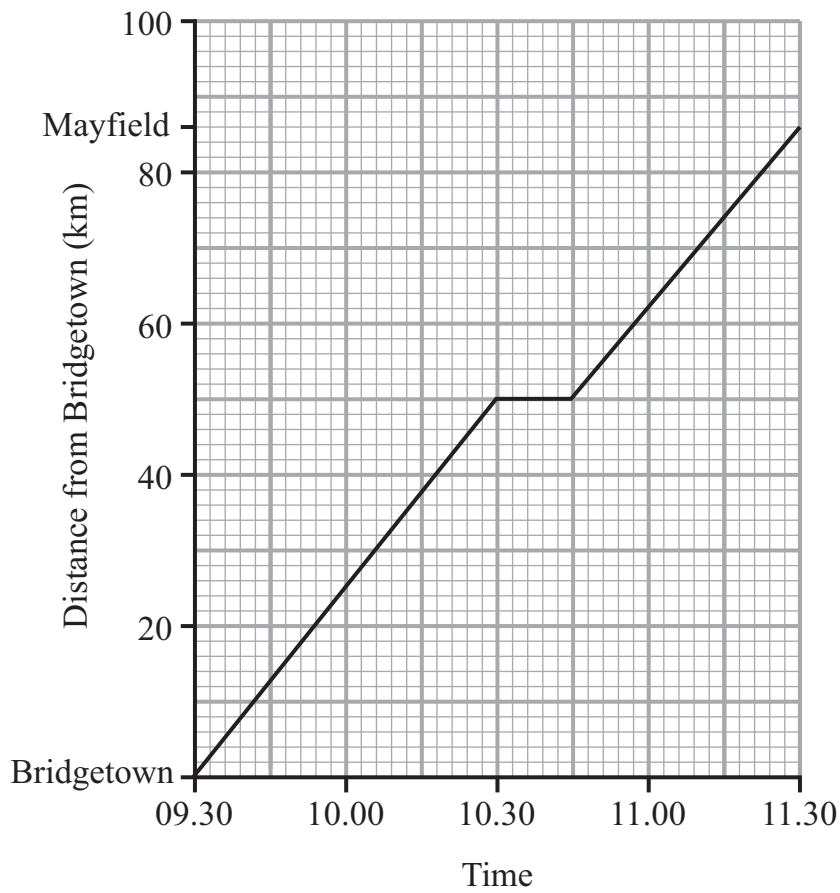

(a) Calculate the average speed for the complete journey from Bridgetown to Mayfield.

Answer _____ km/hr [2]



(b) Further on from Mayfield is Kingsrow which is 100 km from Bridgetown.
A coach leaves Kingsrow at 0945 and travels towards Bridgetown at an average speed of 80 km/hr until it reaches Bridgetown.

(i) Draw a graph to represent its complete journey on the grid opposite. [3]

(ii) Estimate the time at which the two coaches pass each other.

Answer _____ [1]

3 $s = ut + \frac{1}{2}at^2$

Find the value of s when $u = 80$, $a = -5$ and $t = 4$

Answer $s =$ _____ [3]

[Turn over



- 4 (a) Enlarge shape E by scale factor 2 with centre of enlargement $(-3, 4)$.
Label your new shape T.

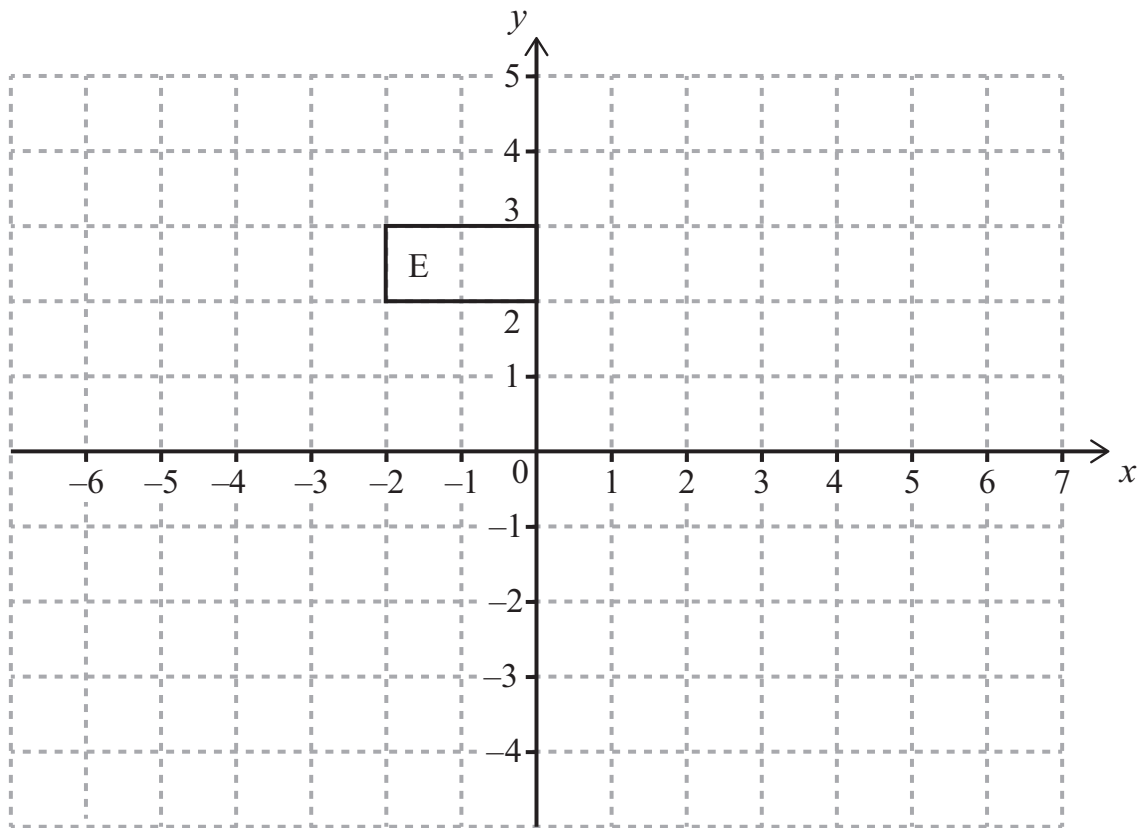

[3]

- (b) Express the ratio of the area of T to the area of E in the form $n : 1$

Answer _____ [1]



5 (a) Reflect triangle A in the line $y = 1$

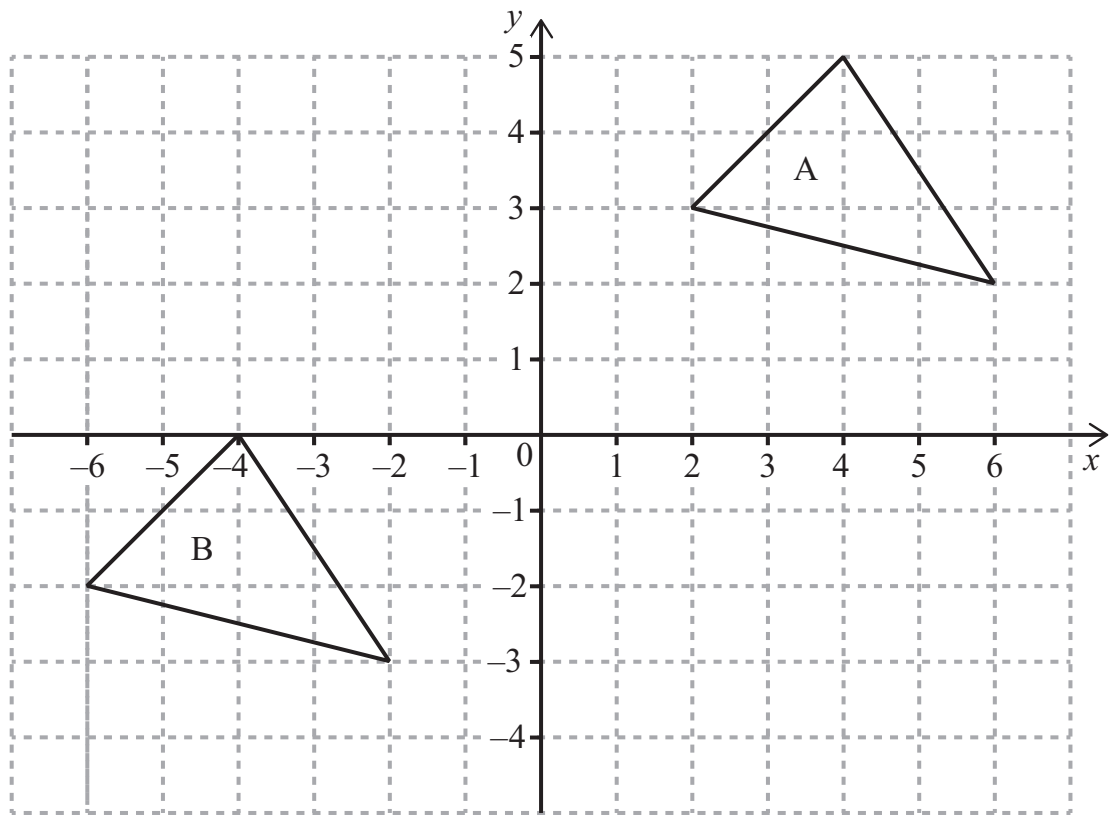

[2]

(b) Describe fully the single transformation that moves triangle A to triangle B.

[2]

[Turn over



- 6 (a) Use only a ruler and a pair of compasses to construct an equilateral triangle of side length 7 cm.
Show all your construction arcs.

[2]

- (b) Use only a ruler and a pair of compasses to bisect the angle ABC in the triangle below.
Show all your construction arcs.

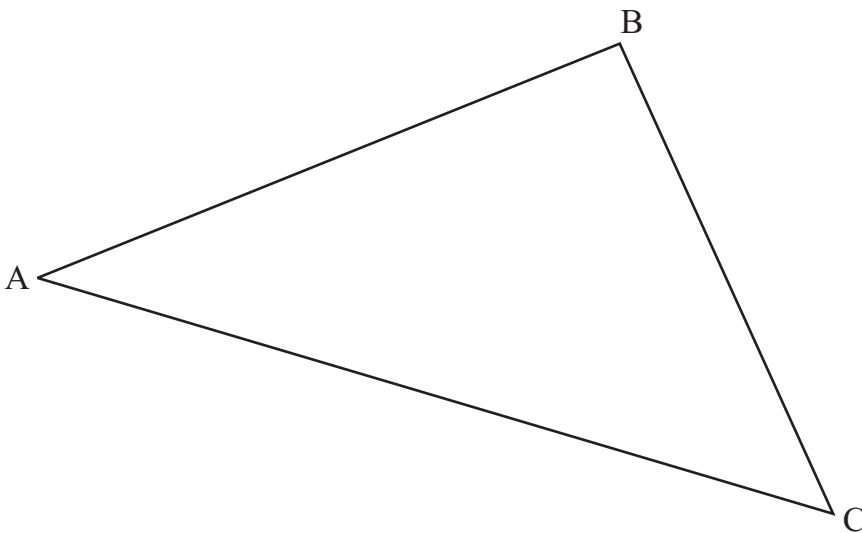

[2]



Quality of written communication will be assessed in this question.

7 Aidan, Ben and Caitlin all spin a spinner 20 times each. They keep track of their scores of 1, 2 and 3 using a tally chart.

	1	2	3
Aidan			+
Ben	/		
Caitlin			

They all used the **same** one of the following four spinners.

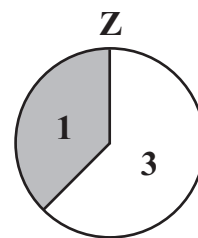
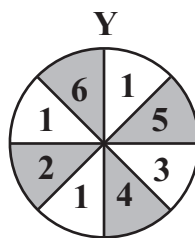
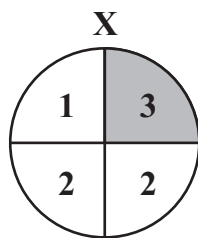
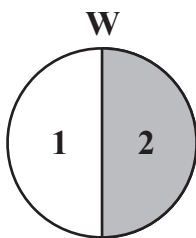

Which spinner do you think they used?

Explain clearly why you have made this choice.

Answer Spinner _____ because _____

[3]



- 8 The heights of patients attending a medical centre are recorded in a frequency table.

Height (cm)	$110 \leq h < 130$	$130 \leq h < 150$	$150 \leq h < 170$	$170 \leq h < 190$
Frequency	47	168	236	29

What is the probability that the next patient who enters the centre has a height between 130 cm and 150 cm?

Answer _____ [2]

- 9 The mass of Particle P has been recorded as 0.000 000176 g.
The mass of Particle Q has been recorded as 14.9×10^{-7} g.
Which particle has the bigger mass and by how much?
Give your answer in standard form.

Answer Particle _____ by _____ g [3]



10 Assume that every day in Northern Ireland can be described as being either wet or dry.
 If it is wet today the probability of it being dry tomorrow is 0.4
 If it is dry today the probability of it being wet tomorrow is 0.2
 On Monday it is wet.

(a) Complete the tree diagram to show the probability of it being wet or dry on Tuesday and Wednesday.

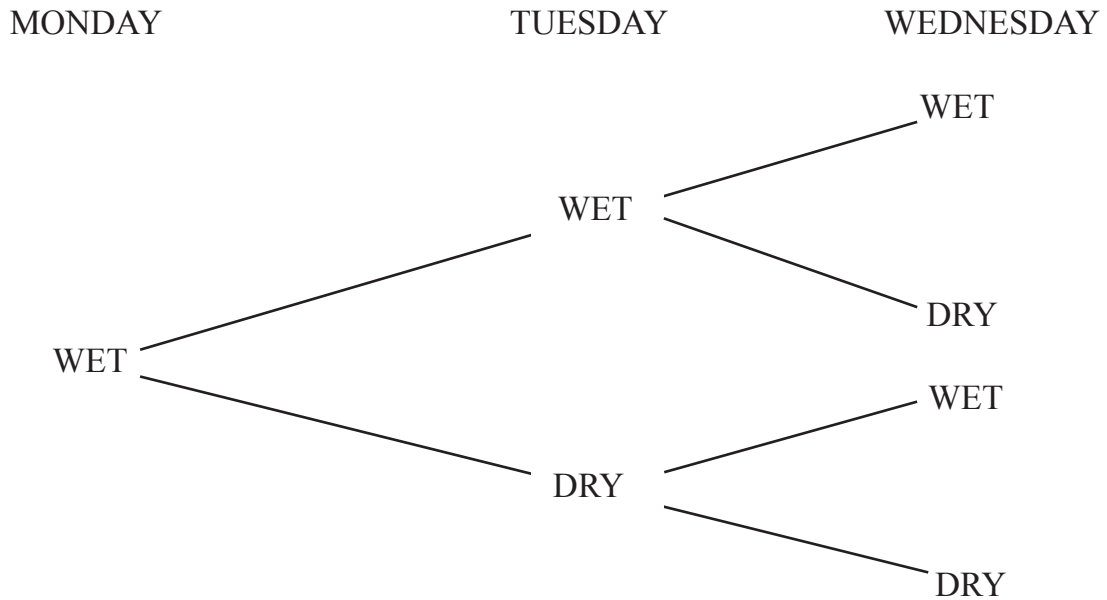

[3]

(b) Calculate the probability that both Tuesday and Wednesday are dry.

Answer _____ [2]

[Turn over



11 Rewrite $3a - b = c(2 - a)$ to make a the subject.

Answer $a =$ _____ [3]

12 Write $0.3\dot{1}\dot{8}$ as a fraction.

Answer _____ [2]



Quality of written communication will be assessed in this question.

- 13 Helen says that the probability of getting exactly one head when two coins are tossed is the same as the probability of getting exactly two heads when four coins are tossed. Is Helen right?

Show clearly all your working.

[4]



14 $\frac{x\sqrt{2}}{5 - \sqrt{5}} = 5 + \sqrt{5}$

Work out the value of x .

Give your answer in the form $a\sqrt{b}$ where a and b are integers.

Answer _____ [4]

THIS IS THE END OF THE QUESTION PAPER





BLANK PAGE
DO NOT WRITE ON THIS PAGE

9469.05 R



16GMT6115

DO NOT WRITE ON THIS PAGE

For Examiner's use only	
Question Number	Marks
1	
2	
3	
4	
5	
6	
7	
8	
9	
10	
11	
12	
13	
14	

Total Marks	
--------------------	--

Examiner Number

--

Permission to reproduce all copyright material has been applied for.
In some cases, efforts to contact copyright holders may have been unsuccessful and CCEA will be happy to rectify any omissions of acknowledgement in future if notified.

9469.05 R



16GMT6116