



Rewarding Learning

General Certificate of Secondary Education
January 2014

--	--	--	--	--

Candidate Number

--	--	--	--

StudentBounty.com

Mathematics

Unit T1

(With calculator)

Foundation Tier



[GMT11]

GMT11

FRIDAY 10 JANUARY, 9.15am–10.45am

TIME

1 hour 30 minutes.

INSTRUCTIONS TO CANDIDATES

Write your Centre Number and Candidate Number in the spaces provided at the top of this page.

You must answer the questions in the spaces provided. Do not write outside the box, around each page, on blank pages or tracing paper.

Complete in blue or black ink only. **Do not write with a gel pen.**

Answer **all twenty-nine** questions.

Any working should be clearly shown in the spaces provided since marks may be awarded for partially correct solutions.

You **may** use a calculator for this paper.

INFORMATION FOR CANDIDATES

The total mark for this paper is 100.

Figures in brackets printed down the right-hand side of pages indicate the marks awarded to each question or part question.

Functional Elements will be assessed in this paper.

Quality of written communication will be assessed in **questions 7 and 21**.

You should have a calculator, ruler, compasses and a protractor.

The Formula Sheet is on page 2.

8690



Formula Sheet

$$\text{Area of trapezium} = \frac{1}{2}(a + b)h$$

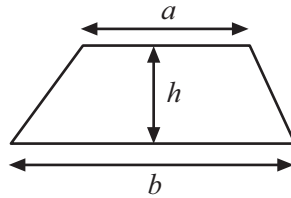

$$\text{Volume of prism} = \text{area of cross section} \times \text{length}$$

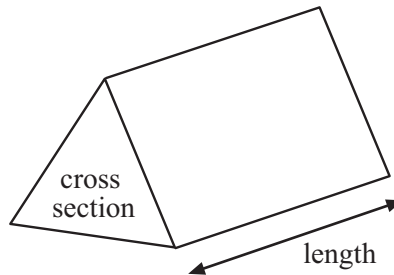

1 (a) Write 100 million in figures.

Answer _____ [1]

(b) Write down the number forty three thousand and twenty six in figures.

Answer _____ [1]

(c) Write down the value of the 4 in the number 34 568

Answer _____ [1]

(d) Write 60% as a decimal.

Answer _____ [1]

Examiner Only









Marks Remark

Total Question 1

[Turn over



- 3 The frequency table and the pictogram illustrate some information about the number of letters received in an office during one week.

Monday		Monday					
Tuesday	25	Tuesday					
Wednesday	20	Wednesday					
Thursday		Thursday					
Friday	15	Friday					

- (a) Complete the frequency table for Monday. [2]
- (b) Complete the pictogram for Tuesday. [1]
- (c) In total 145 letters are received in the week.
Complete both the frequency table and the pictogram for Thursday. [2]
- (d) Which day represents the mode? Why do you think the mode is on this day?

_____ because _____

_____ [2]

Examiner Only

Marks Remark

Total Question 3

[Turn over



5 Which **metric** unit is the most suitable to measure

(a) the distance from Coleraine to Dungannon,

Answer _____ [1]

(b) the weight of a potato,

Answer _____ [1]

(c) the capacity of a large can of engine oil?

Answer _____ [1]

Examiner Only	
Marks	Remark
Total Question 5	

6 Here is a sequence of shapes made using sticks.

Shape 1



Shape 2

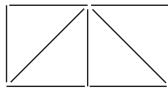

Shape 3

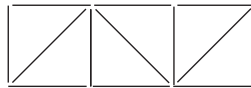

Shape 4

(a) Draw Shape 4 of the sequence.

[1]

(b) Complete the table below for the sequence of shapes.

Shape Number	1	2	3	4	5
Number of sticks	5	9	13		

[1]

(c) Look at the numbers in the 'Number of sticks' row. Write down the pattern.

Answer _____ [1]

(d) Explain why you could not have a shape in the sequence using 100 sticks.

Answer _____ [1]

Total Question 6	

[Turn over



Quality of written communication will be assessed in this question.

Examiner Only	
Marks	Remark

7 Boxes of Tasty Tea come in three sizes

size A 60 bags for £1.80

size B 80 bags for £2.24

size C 150 bags for £4.80

Find out which size is the best bargain.

Show clearly your method and all your working.

Answer size _____ [4]

Total Question 7	

8 Tiles cost £7.48 each. How many can be bought for £100?

Answer _____ [2]

Total Question 8	



- 9 Nine students each completed an experiment.
The time taken (in minutes) by each student is recorded.

32 17 30 18 21 22 30 24 29

- (a) What is the median time?

Answer _____ minutes [2]

- (b) Calculate the range of the times.

Answer _____ minutes [1]

Examiner Only	
Marks	Remark
Total Question 9	

- 10 The distance chart below shows some distances in miles between various places.

Hull					
60	Leeds				
47	72	Lincoln			
97	44		Manchester		
66		47	39	Sheffield	
	24		71	57	York

Jane travels from Hull to Lincoln, then from Lincoln to Manchester and finally from Manchester to York.

The total distance she covers is 203 miles.

Insert the distance from Lincoln to Manchester in the chart.

[2]

Total Question 10	

[Turn over



(b)

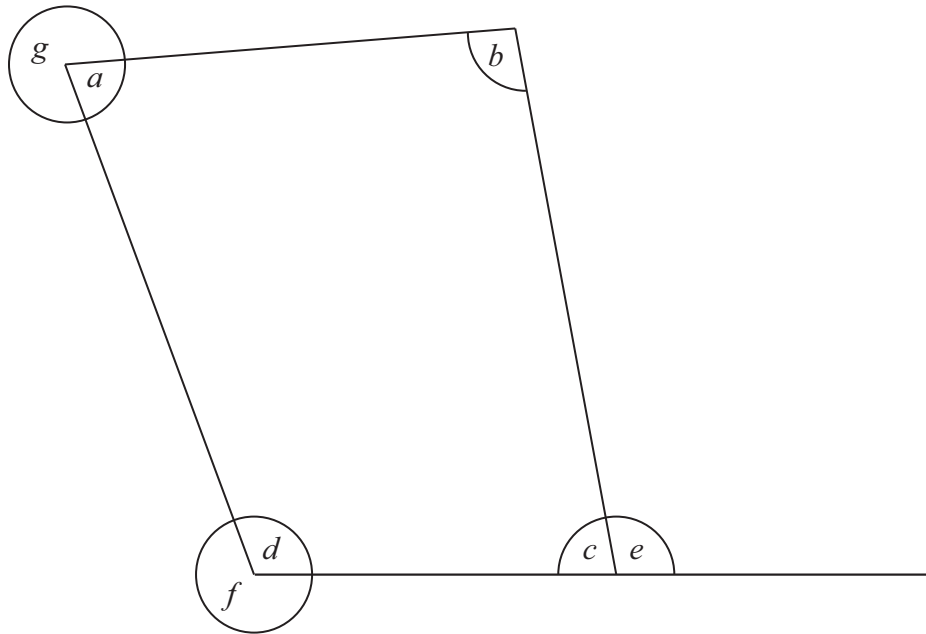

From the diagram above write down the letter of an angle which is

(i) acute,

Answer _____ [1]

(ii) obtuse,

Answer _____ [1]

(iii) reflex.

Answer _____ [1]

Examiner Only

Marks Remark

Total Question 11

[Turn over



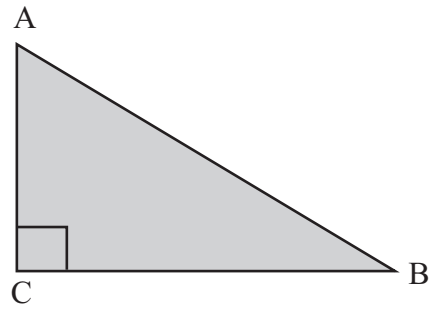

The sketch above shows a large garden ABC which is in the shape of a right-angled triangle. The side $CB = 160\text{ m}$ and the side $AC = 110\text{ m}$. Using a scale of $1\text{ cm} = 20\text{ m}$, construct a scale drawing to represent the garden.

[2]

Examiner Only	
Marks	Remark
Total Question 12	



13 (a) Write down the value of 9^2

Answer _____ [1]

(b) Calculate the value of $\sqrt{2.56}$

Answer _____ [1]

(c) Calculate the value of 3.2^2

Answer _____ [1]

Examiner Only

Marks Remark

Total Question 13

14 (a) Put these decimals in order of size starting with the smallest

0.7 0.52 0.413

Answer _____, _____, _____ [1]

(b) On the number line shown

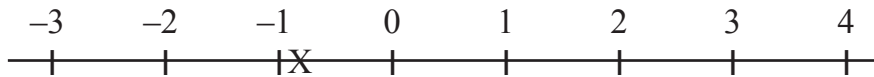

(i) estimate the decimal marked by the letter X

Answer _____ [1]

(ii) draw an arrow to show the position of the decimal 3.14 [1]

Total Question 14

[Turn over



17

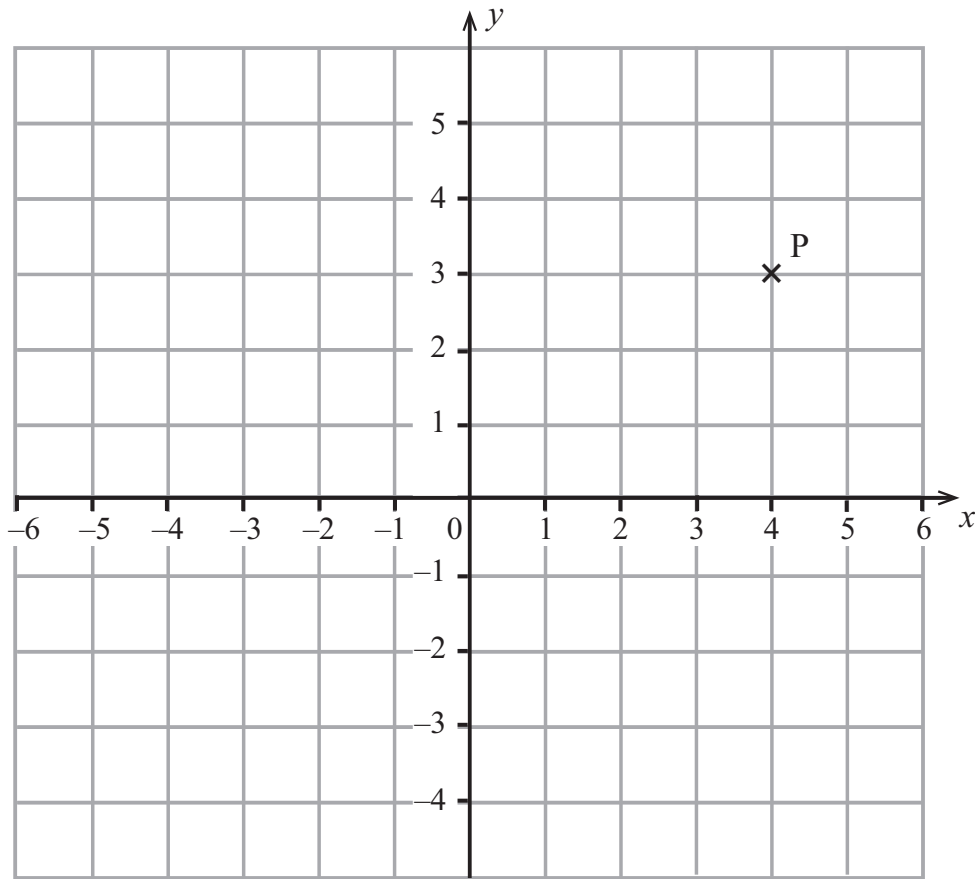

- (a) Write down the coordinates of the point P which is marked on the grid above.

Answer P (____, ____) [1]

- (b) On the grid above, plot and label the points A (-5, 4) and B (3, -2). [2]

Examiner Only	
Marks	Remark
Total Question 17	
Total Question 18	

18 Solve the following equations

(a) $x - 3 = 15$

Answer $x =$ _____ [1]

(b) $4y = 36$

Answer $y =$ _____ [1]



19

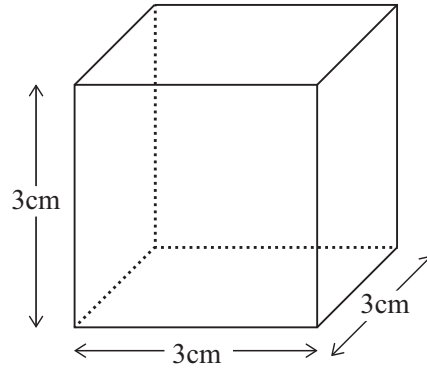

(a) Draw a net of this cube on the 1 cm grid below.

[2]

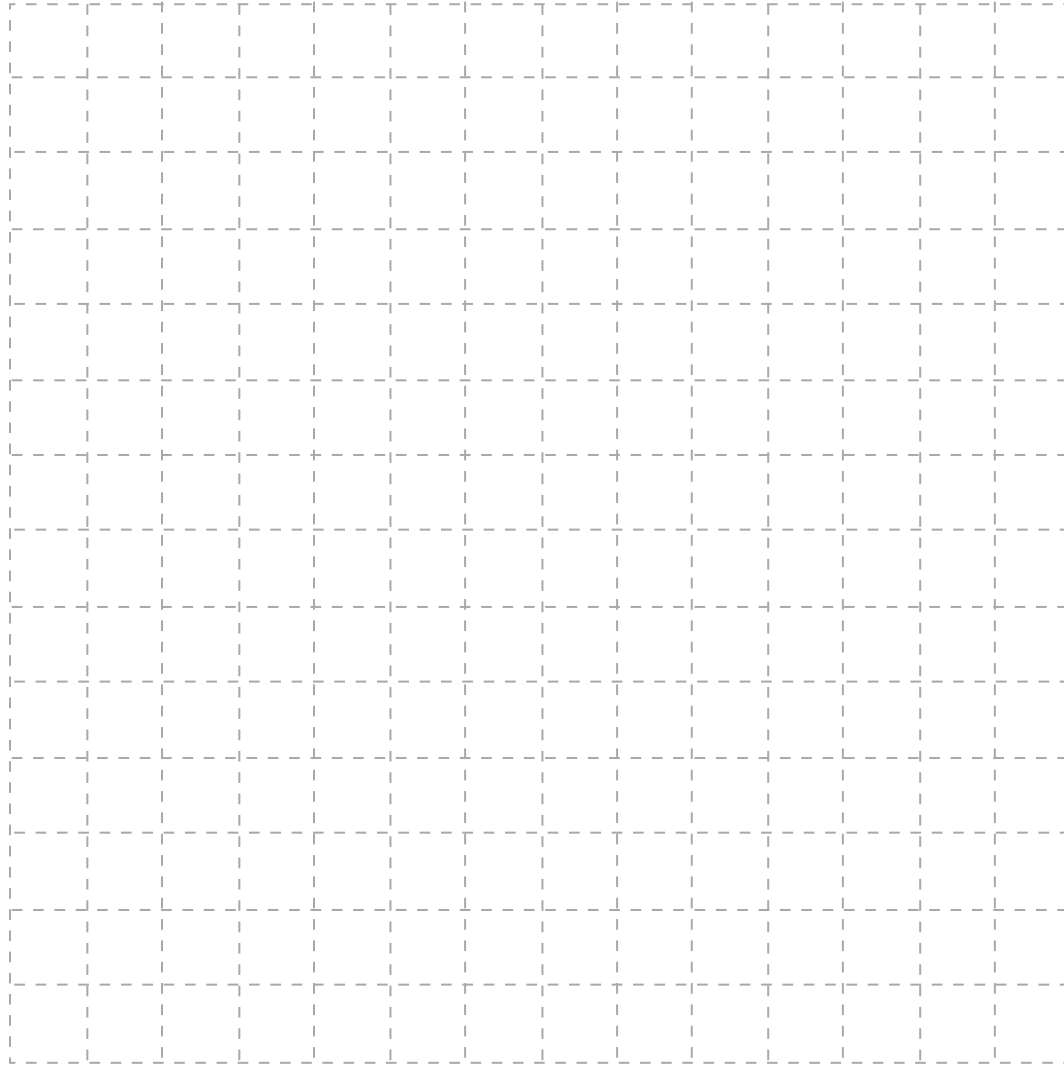

(b) Find the volume of this cube.

Answer _____ [3]

Examiner Only

Marks Remark

Total Question 19

[Turn over



Quality of written communication will be assessed in this question.

21 (a) Work out the value of $2^2 \times 3^3$ showing each step of your working.

Answer _____ [2]

(b) Which of the following fractions is nearest in value to $\frac{1}{4}$?

$\frac{2}{10}$ $\frac{3}{20}$ $\frac{7}{30}$ $\frac{11}{40}$

Show clearly how you reach your answer.

Answer _____ [2]

Examiner Only

Marks Remark

Total Question 21

[Turn over



24

Year	2008	2009	2010	2011	2012
Rainfall (cm)	60.5	62.5	62.0	61.0	

The mean rainfall over these 5 years was 62 cm. What was the rainfall in 2012?

Answer _____ cm [3]

Examiner Only

Marks	Remark
Total Question 24	

- 25 The table below shows the number of pairs of shoes of different colours sold in a shop one day.

Colour	Black	Brown	Blue	Other
Number	35	20	18	17
Angle				

Draw a clearly labelled pie chart to show the number of pairs of shoes of each colour.

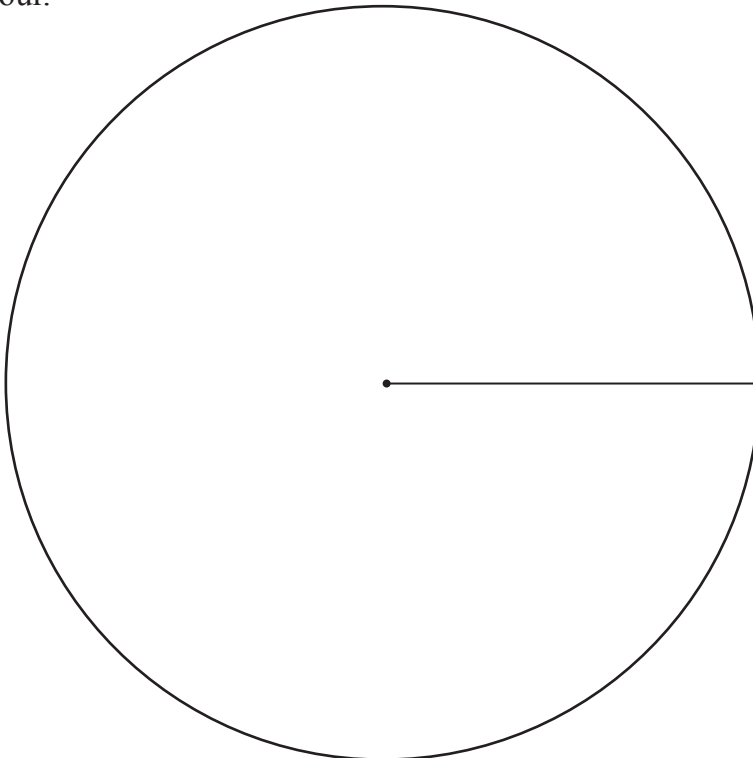

[4]

Total Question 25	

[Turn over]

8690



26 The two graphs below show similar information but look different.

Graph A

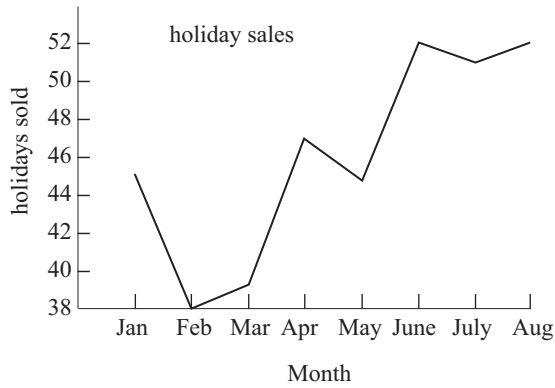

Graph B

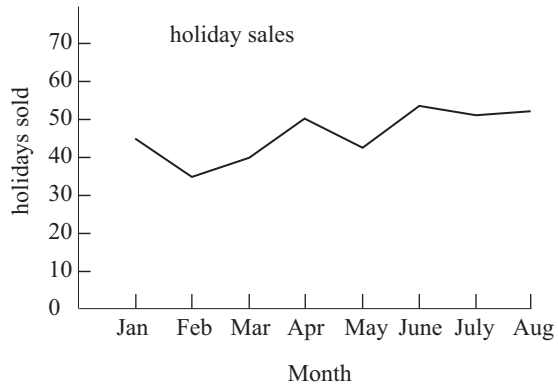

(a) Which graph appears to show the biggest increase in sales?

Answer Graph _____ [1]

(b) What causes this graph to be misleading?

Answer _____ [1]

Examiner Only	
Marks	Remark
Total Question 26	



27 Calculate the size of angle x in the diagram below.

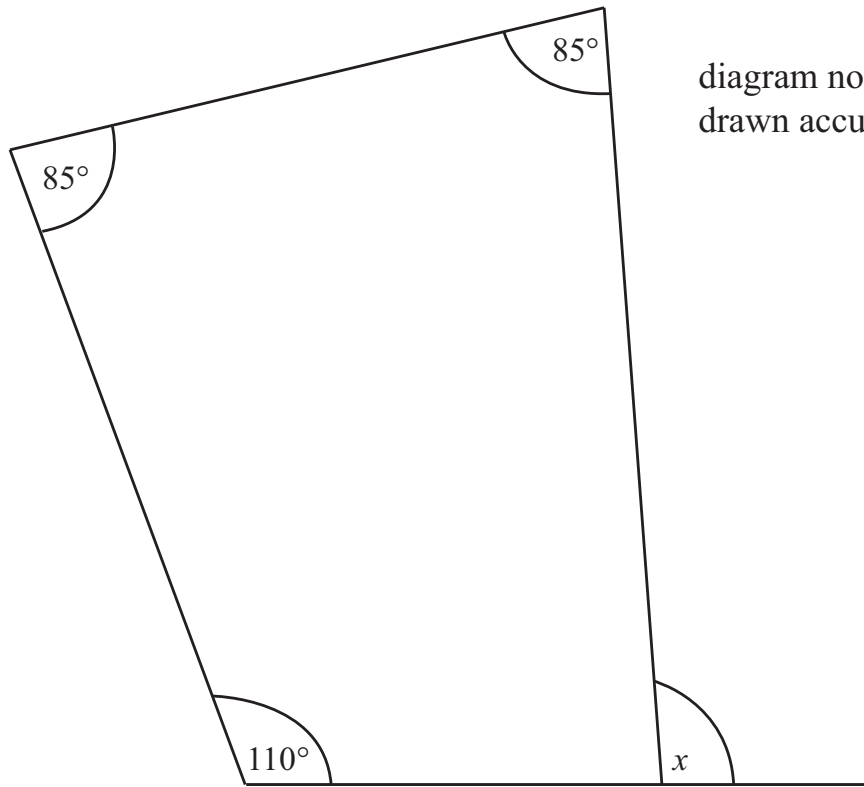

diagram not
drawn accurately

Answer $x =$ _____ $^\circ$ [3]



Examiner Only

Marks Remark

Total Question 27

[Turn over



	1000	1300	1600	
Dublin Connolly				
Newry 	1112	1412	1712	
Poyntzpass				
Scarva				
Portadown	0845 0945 1045 1134 1145 1245 1345	1434 1445 1545 1645	1734 1745 1845	
Lurgan	0851 0951 1051 1144 1151 1251 1351	1451 1551 1651	1751 1851	
Moirá	0857 0957 1057 1157 1257 1357	1457 1557 1657	1757 1857	
Lisburn	0910 1010 1110 1203 1210 1310 1410	1510 1610 1710	1810 1910	
Hilden	0912 1012 1112 1212 1312 1412	1512 1612 1712	1812 1912	
Lambeg	0914 1014 1114 1214 1314 1414	1514 1614 1714	1814 1914	
Derriaghá	0916 1016 1116 1216 1316 1416	1516 1616 1716	1816 1916	
Dunmurry	0919 1019 1119 1219 1319 1419	1519 1619 1719	1819 1919	
Finaghá	0922 1022 1122 1222 1322 1422	1522 1622 1722	1822 1922	
Balmoral	0924 1024 1124 1224 1324 1424	1524 1624 1724	1824 1924	
Adelaide	0926 1026 1126 1226 1326 1426	1526 1626 1726	1826 1926	
Great Victoria Street	0930 1030 1130 1230 1330 1430	1530 1630 1730	1830 1930	
Great Victoria Street	0834 0934 1034 1134 1234 1334 1434	1534 1634 1734	1834 1934	
City Hospital	0837 0937 1037 1137 1237 1337 1437	1537 1637 1737	1837 1937	
Botanic	0839 0939 1039 1139 1239 1339 1439	1539 1639 1739	1839 1939	
Belfast Central 	0842 0942 1042 1142 1216 1242 1342 1442	1507 1542 1642 1742	1807 1842 1942	
Belfast Central	0845 0945 1045 1145	1245 1345 1445	1545 1645 1745	1845 1945
Titanic Qtr (Bridge End)	0848 0948 1048 1148	1248 1348 1448	1548 1648 1748	1848 1948
Sydenham 	0851 0951 1051 1151	1251 1351 1451	1551 1651 1751	1851 1948
Hollywood	0855 0955 1055 1155	1255 1355 1455	1555 1655 1755	1855 1955
Marino	0857 0957 1057 1157	1257 1357 1457	1557 1657 1757	1857 1957
Cultra	0859 0959 1059 1159	1259 1359 1459	1559 1659 1759	1859 1959
Seahill	0902 1002 1102 1202	1302 1402 1502	1602 1702 1802	1902 2002
Helen's Bay	0905 1005 1105 1205	1305 1405 1505	1605 1705 1805	1905 2005
Carnalea	0909 1009 1109 1209	1309 1409 1509	1609 1709 1809	1909 2009
Bangor West	0911 1011 1111 1211	1311 1411 1511	1611 1711 1811	1911 2011
Bangor	0916 1016 1116 1216	1316 1416 1516	1616 1716 1816	1916 2016

© Adapted from Translink Timetable (www.translink.co.uk). With kind permission

- (a) Sarah takes the 1134 train from Portadown to Belfast Central.
How long should the journey take?

Answer _____ minutes [1]





DO NOT WRITE ON THIS PAGE

8690



DO NOT WRITE ON THIS PAGE

For Examiner's use only	
Question Number	Marks
1	
2	
3	
4	
5	
6	
7	
8	
9	
10	
11	
12	
13	
14	
15	
16	
17	
18	
19	
20	
21	
22	
23	
24	
25	
26	
27	
28	
29	

Total Marks	
--------------------	--

Examiner Number

Permission to reproduce all copyright material has been applied for.
In some cases, efforts to contact copyright holders may have been unsuccessful and CCEA will be happy to rectify any omissions of acknowledgement in future if notified.

