



Rewarding Learning

General Certificate of Secondary Education
January 2014

--	--	--	--	--

Candidate Number

--	--	--	--

StudentBounty.com

Mathematics

Unit T2

(With calculator)

Foundation Tier



[GMT21]

GMT21

FRIDAY 10 JANUARY, 9.15 am–10.45 am

TIME

1 hour 30 minutes.

INSTRUCTIONS TO CANDIDATES

Write your Centre Number and Candidate Number in the spaces provided at the top of this page.

You must answer the questions in the spaces provided. Do not write outside the box, around each page, on blank pages or tracing paper.

Complete in blue or black ink only. **Do not write with a gel pen.**

Answer **all twenty-nine** questions.

Any working should be clearly shown in the spaces provided since marks may be awarded for partially correct solutions.

You **may** use a calculator for this paper.

INFORMATION FOR CANDIDATES

The total mark for this paper is 100.

Figures in brackets printed down the right-hand side of pages indicate the marks awarded to each question or part question.

Functional Elements will be assessed in this paper.

Quality of written communication will be assessed in **questions 1 and 16(b)**.

You should have a calculator, ruler, compasses and a protractor.

The Formula Sheet is on page 2.

8691



Formula Sheet

$$\text{Area of trapezium} = \frac{1}{2}(a + b)h$$

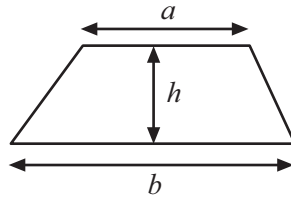

$$\text{Volume of prism} = \text{area of cross section} \times \text{length}$$

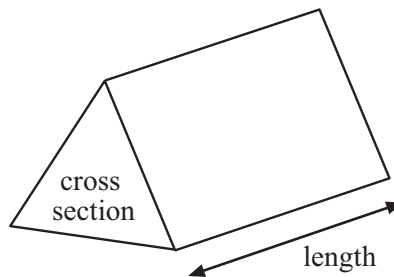

Quality of written communication will be assessed in this question.

1 (a) Work out the value of $2^2 \times 3^3$ showing each step of your working.

Answer _____ [2]

(b) Which of the following fractions is nearest in value to $\frac{1}{4}$?

$\frac{2}{10}$ $\frac{3}{20}$ $\frac{7}{30}$ $\frac{11}{40}$

Show clearly how you reach your answer.

Answer _____ [2]

Examiner Only

Marks Remark

Total Question 1

[Turn over



2 (a) From the numbers in the list below

24 56 81 40 25 66 59 90 27

(i) write down a square number,

Answer _____ [1]

(ii) write down a cube number.

Answer _____ [1]

(b) Martha's grandmother's age on her next birthday will be both a square number and a cube number at the same time.

What age is Martha's grandmother now?

Answer _____ [2]

Examiner Only	
Marks	Remark
Total Question 2	
Total Question 3	

3 Anne bought pink and blue ribbon for her Nursery School.

She bought 3.2 metres of pink ribbon and 2.6 metres of blue ribbon and paid the shopkeeper £8.89

The pink ribbon cost £1.60 per metre.

How much did the blue ribbon cost per metre?

Show clearly how you worked out your answer.

Answer £ _____ [4]



4

Year	2008	2009	2010	2011	2012
Rainfall (cm)	60.5	62.5	62.0	61.0	

The mean rainfall over these 5 years was 62 cm. What was the rainfall in 2012?

Answer _____ cm [3]

Examiner Only

Marks	Remark
Total Question 4	
Total Question 5	

- 5 The table below shows the number of pairs of shoes of different colours sold in a shop one day.

Colour	Black	Brown	Blue	Other
Number	35	20	18	17
Angle				

Draw a clearly labelled pie chart to show the number of pairs of shoes of each colour.

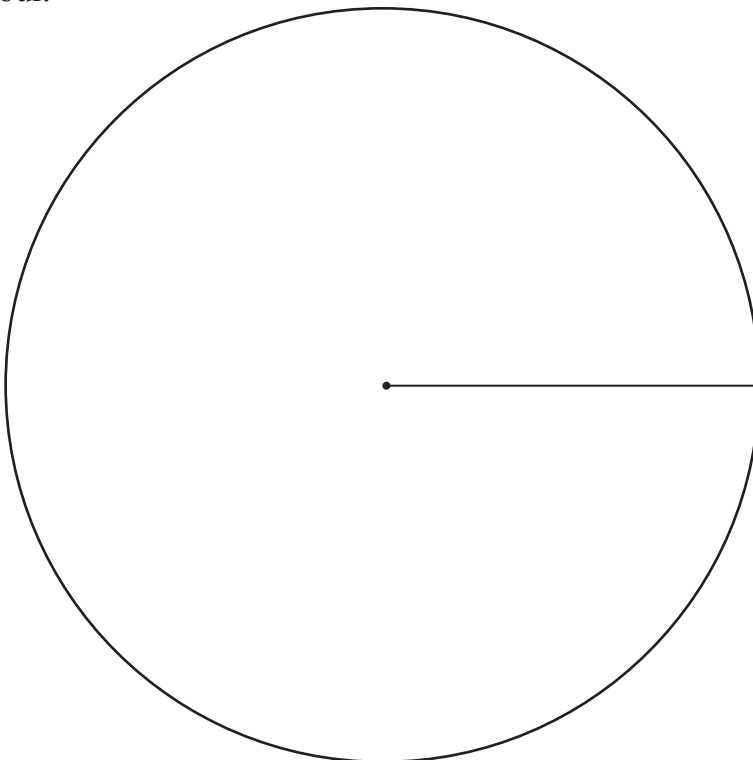

[4]

Total Question 5

[Turn over]

8691



6 The two graphs below show similar information but look different.

Graph A

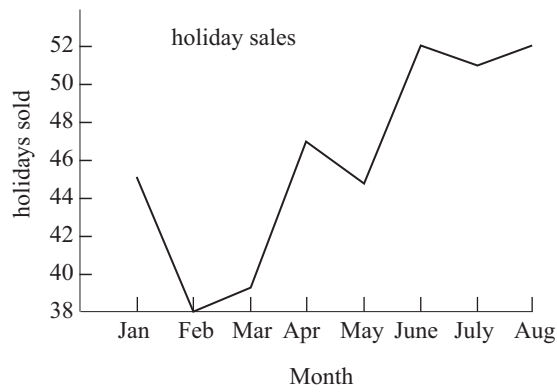

Graph B

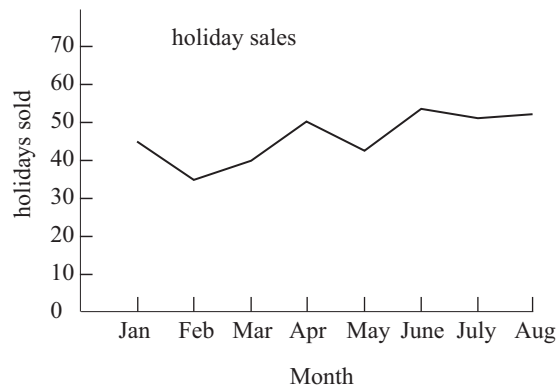

(a) Which graph appears to show the biggest increase in sales?

Answer Graph _____ [1]

(b) What causes this graph to be misleading?

Answer _____ [1]

Examiner Only	
Marks	Remark
Total Question 6	



7 Calculate the size of angle x in the diagram below.

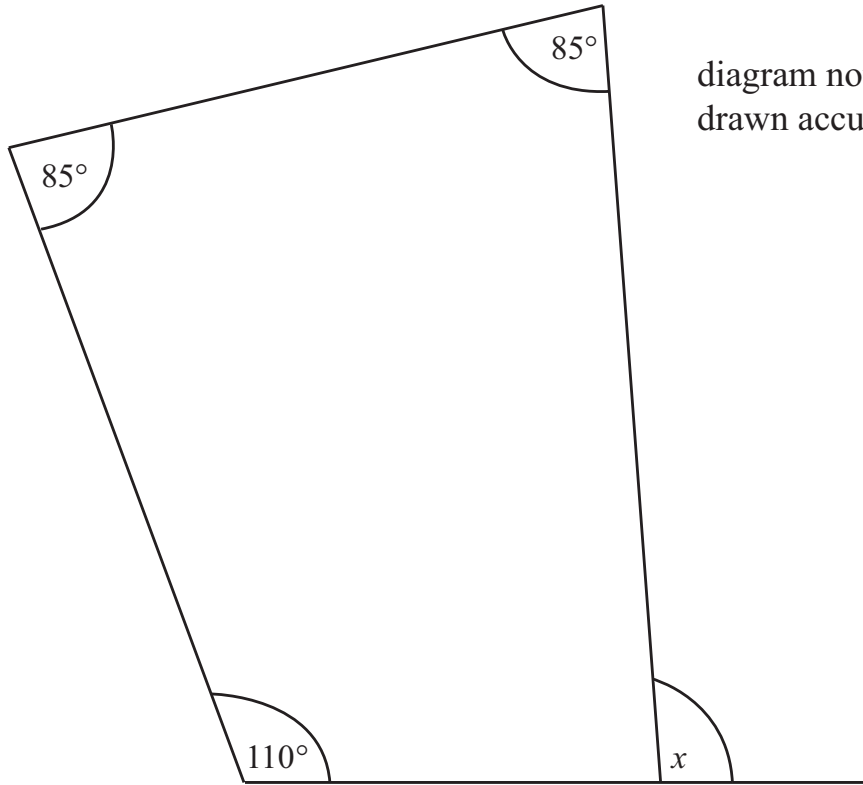

diagram not
drawn accurately

Answer $x =$ _____ $^\circ$ [3]

Examiner Only

Marks Remark

Total Question 7

[Turn over



Dublin Connolly	1000			1300			1600		
Newry L	1112			1412			1712		
Poyntzpass									
Scarva									
Portadown	0845 0945 1045	1134 1145 1245 1345	1434 1445 1545 1645	1734 1745 1845					
Lurgan	0851 0951 1051	1144 1151 1251 1351	1451 1551 1651	1751 1851					
Moirá	0857 0957 1057	1157 1257 1357	1457 1557 1657	1757 1857					
Lisburn	0910 1010 1110	1203 1210 1310 1410	1510 1610 1710	1810 1910					
Hilden	0912 1012 1112	1212 1312 1412	1512 1612 1712	1812 1912					
Lambeg	0914 1014 1114	1214 1314 1414	1514 1614 1714	1814 1914					
Derríagh	0916 1016 1116	1216 1316 1416	1516 1616 1716	1816 1916					
Dunmurry	0919 1019 1119	1219 1319 1419	1519 1619 1719	1819 1919					
Finagh	0922 1022 1122	1222 1322 1422	1522 1622 1722	1822 1922					
Balmoral	0924 1024 1124	1224 1324 1424	1524 1624 1724	1824 1924					
Adelaide	0926 1026 1126	1226 1326 1426	1526 1626 1726	1826 1926					
Great Victoria Street	0930 1030 1130	1230 1330 1430	1530 1630 1730	1830 1930					
Great Victoria Street	0834 0934 1034 1134	1234 1334 1434	1534 1634 1734	1834 1934					
City Hospital	0837 0937 1037 1137	1237 1337 1437	1537 1637 1737	1837 1937					
Botanic	0839 0939 1039 1139	1239 1339 1439	1539 1639 1739	1839 1939					
Belfast Central M	0842 0942 1042 1142	1216 1242 1342 1442	1507 1542 1642 1742	1807 1842 1942					
Belfast Central	0845 0945 1045 1145	1245 1345 1445	1545 1645 1745	1845 1945					
Titanic Qtr (Bridge End)	0848 0948 1048 1148	1248 1348 1448	1548 1648 1748	1848 1948					
Sydenham L	0851 0951 1051 1151	1251 1351 1451	1551 1651 1751	1851 1948					
Hollywood	0855 0955 1055 1155	1255 1355 1455	1555 1655 1755	1855 1955					
Marino	0857 0957 1057 1157	1257 1357 1457	1557 1657 1757	1857 1957					
Cultra	0859 0959 1059 1159	1259 1359 1459	1559 1659 1759	1859 1959					
Seahill	0902 1002 1102 1202	1302 1402 1502	1602 1702 1802	1902 2002					
Helen's Bay	0905 1005 1105 1205	1305 1405 1505	1605 1705 1805	1905 2005					
Carnalea	0909 1009 1109 1209	1309 1409 1509	1609 1709 1809	1909 2009					
Bangor West	0911 1011 1111 1211	1311 1411 1511	1611 1711 1811	1911 2011					
Bangor	0916 1016 1116 1216	1316 1416 1516	1616 1716 1816	1916 2016					

© Adapted from Translink Timetable (www.translink.co.uk). With kind permission

- (a) Sarah takes the 1134 train from Portadown to Belfast Central.
How long should the journey take?

Examiner Only	
Marks	Remark



10 (a) Simplify

$$5x + 2y - 3x - 5y$$

Answer _____ [2]

(b) Solve

$$7x - 3 = 18$$

Answer $x =$ _____ [2]

(c) Solve

$$\frac{x}{20} = 2$$

Answer $x =$ _____ [1]

Examiner Only

Marks Remark

Total Question 10

[Turn over



11 (a) Complete the table of values for the equation $y = 3x + 5$

x	-2	-1	0	1	2	3
y	-1		5	8		14

[1]

(b) On the grid below, draw the graph of $y = 3x + 5$ between $x = -2$ and $x = 3$

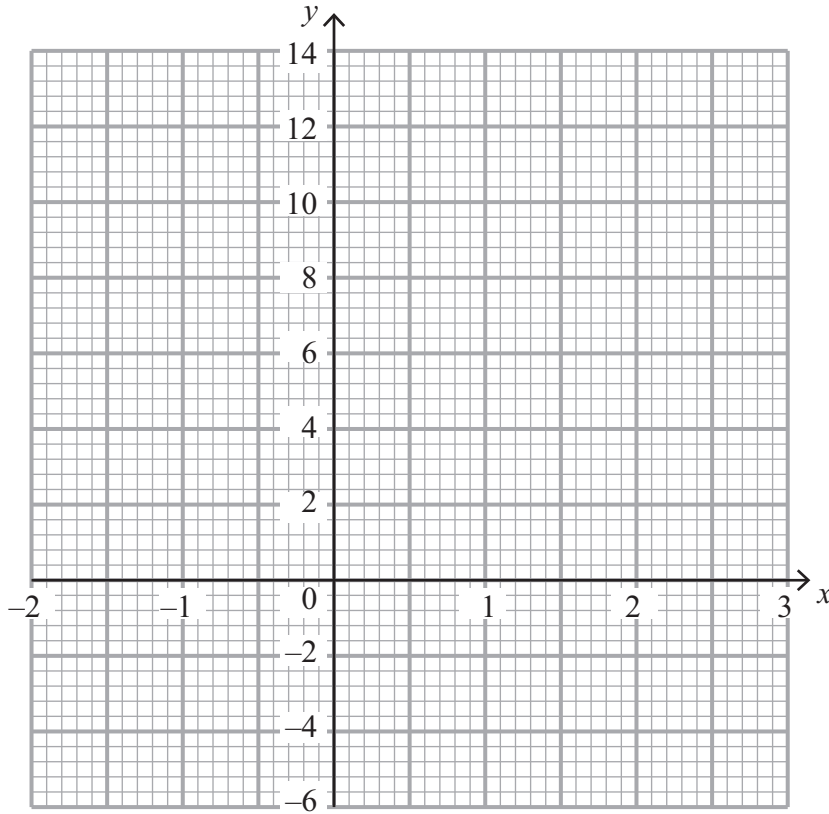

[2]

(c) Draw the line $x = 2$ on the same grid.

[1]

Examiner Only	
Marks	Remark
Total Question 11	



14 The table shows the temperature of some liquids as they cool in a freezer.

Time (minutes)	5	10	15	18	25	30	30
Temperature ($^{\circ}\text{C}$)	35	31	24	22	12	7	6

Examiner Only	
Marks	Remark

(a) Draw a scatter graph for this data.

[2]

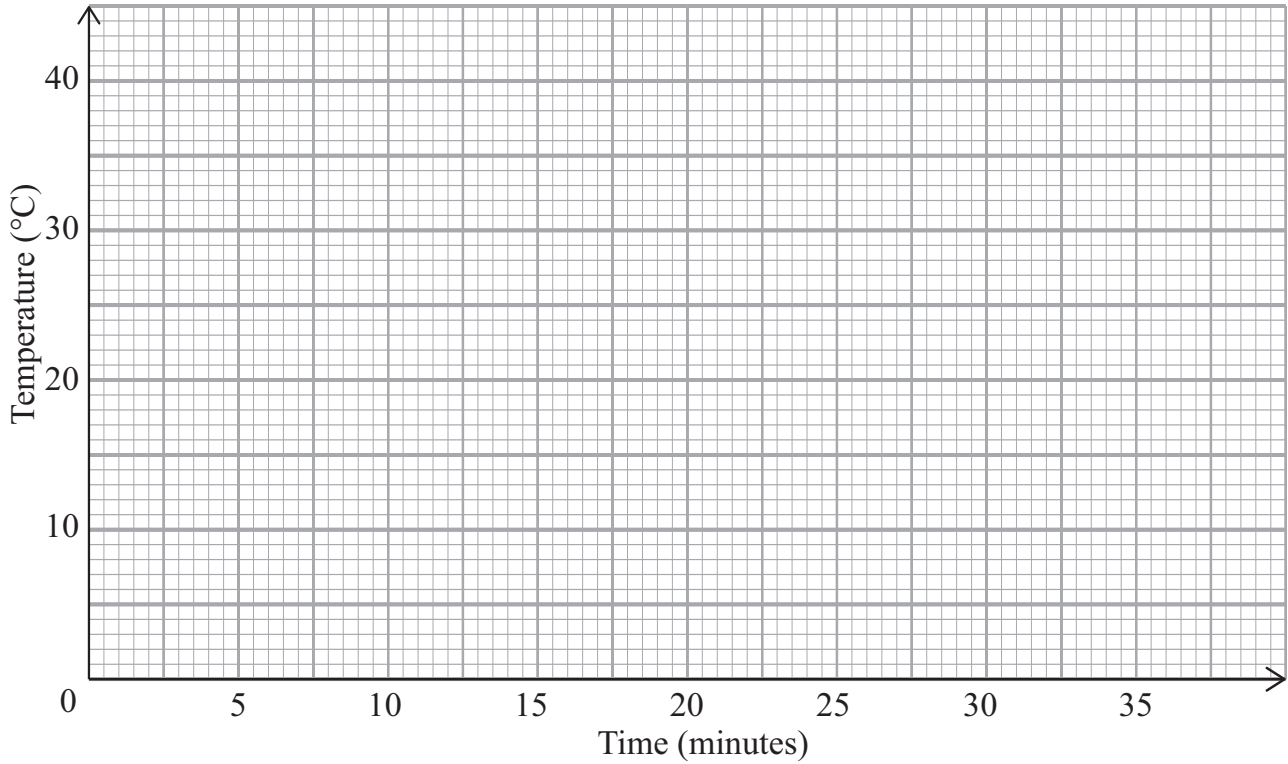

(b) Draw a line of best fit.

[1]

(c) Estimate the time taken for a liquid to reach freezing point (0°C).

Answer _____ minutes [1]

Examiner Only	
Marks	Remark



(d) Describe the correlation.

Answer _____ [1]

Examiner Only	
Marks	Remark
Total Question 14	
Total Question 15	

15 Twenty two pupils were asked to record the time (in minutes) they spent on their homework last Monday night. Their responses are listed below.

40 55 80 60 50 55 65 40 120 100 90
55 60 110 100 120 75 50 80 85 60 45

Construct a stem and leaf diagram to illustrate this data.

[3]



18 Angela buys 5 DVDs and 4 CDs.
 Each DVD costs d pounds. Each CD costs c pounds.
 Write down an expression for the total cost.

Examiner Only	
Marks	Remark
Total Question 18	

Answer _____ [2]

19 The n^{th} term of a sequence is given by $n^2 - 1$

(a) Write down the first 3 terms of this sequence.

Answer _____, _____, _____ [2]

(b) Explain why 101 cannot be a term in this sequence.

Answer _____ [1]

Total Question 19	

20 Solve $7e + 3 = 4e + 5$

Total Question 20	

Answer $e =$ _____ [3]



23 The table below shows the weights of fish caught in a competition.

Weight (g)	Frequency
$0 < w \leq 150$	10
$150 < w \leq 300$	25
$300 < w \leq 450$	18
$450 < w \leq 600$	12
$600 < w \leq 750$	10
$750 < w \leq 900$	5

Draw a frequency polygon for this data.

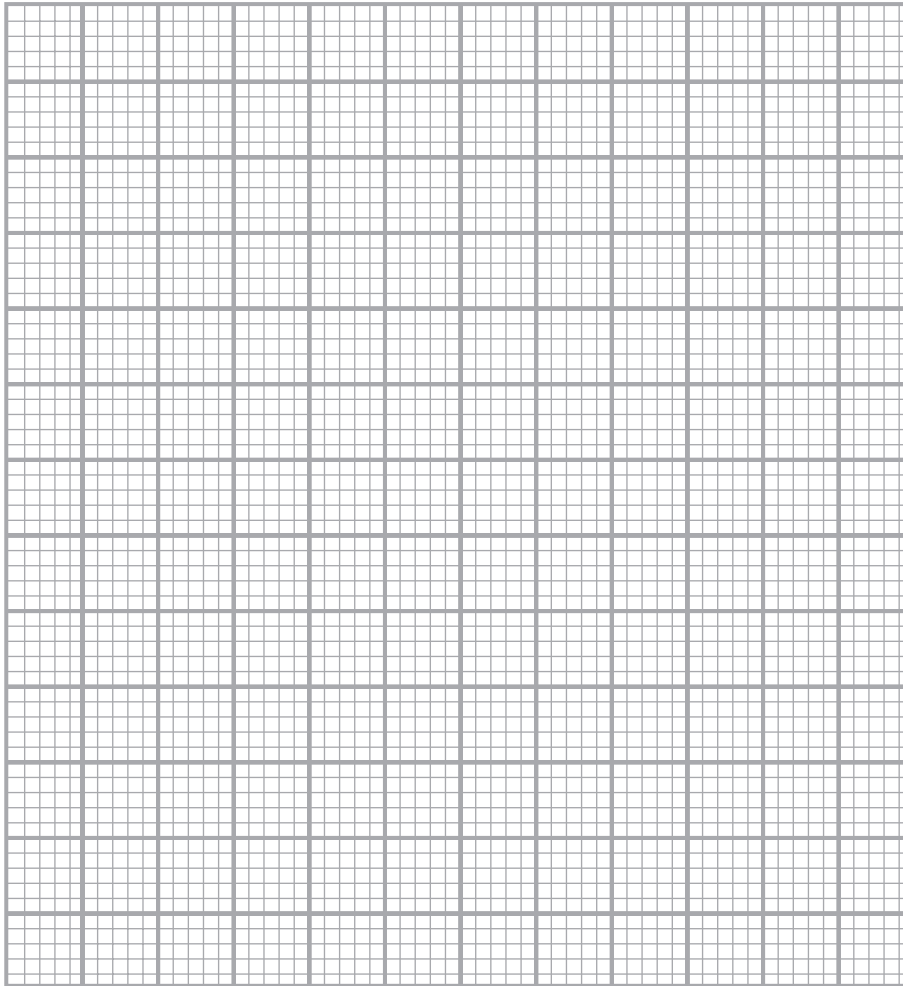

Examiner Only	
Marks	Remark
Total Question 23	

[3]



24 A student wishes to carry out a survey relating to television viewing by the general public.
Her first question is

“What age are you?”

Answer

(a) Give one criticism of this question.

_____ [1]

(b) Design a more suitable question with appropriate response boxes for her to record the age of those being surveyed.

[2]

Examiner Only	
Marks	Remark
Total Question 24	
Total Question 25	

25 The first five terms of a sequence are 9, 13, 17, 21, 25
Find an expression, in terms of n , for the n^{th} term of this sequence.

Answer _____ [2]

[Turn over



28 Expand and simplify $3(2w - 1) - 2(w - 4)$

Answer _____ [2]

Examiner Only

Marks Remark

Total Question 28

29 Use the method of trial and improvement to find the solution to the equation $x^3 + 3x = 47$

Give your answer correct to 1 decimal place.

Show all your working.

Answer $x =$ _____ [4]

Total Question 29

THIS IS THE END OF THE QUESTION PAPER



DO NOT WRITE ON THIS PAGE

For Examiner's use only	
Question Number	Marks
1	
2	
3	
4	
5	
6	
7	
8	
9	
10	
11	
12	
13	
14	
15	
16	
17	
18	
19	
20	
21	
22	
23	
24	
25	
26	
27	
28	
29	

Total Marks	
--------------------	--

Examiner Number

Permission to reproduce all copyright material has been applied for.
In some cases, efforts to contact copyright holders may have been unsuccessful and CCEA
will be happy to rectify any omissions of acknowledgement in future if notified.

