



Rewarding Learning

General Certificate of Secondary Education
January 2014

Centre Number

--	--	--	--	--

Candidate Number

--	--	--	--

Mathematics

Unit T6 Paper 2

(With calculator)

Higher Tier



[GMT62]

GMT62

WEDNESDAY 15 JANUARY 10.45 am–12.00 noon

TIME

1 hour 15 minutes.

INSTRUCTIONS TO CANDIDATES

Write your Centre Number and Candidate Number in the spaces provided at the top of this page.

You must answer the questions in the spaces provided. Do not write outside the box, around each page, on blank pages or tracing paper.

Complete in blue or black ink only. **Do not write with a gel pen.**

Answer **all sixteen** questions.

Any working should be clearly shown in the spaces provided since marks may be awarded for partially correct solutions.

You **may** use a calculator for this paper.

INFORMATION FOR CANDIDATES

The total mark for this paper is 50.

Figures in brackets printed down the right-hand side of pages indicate the marks awarded to each question or part question.

Functional Elements will be assessed in this paper.

Quality of written communication will be assessed in **question 10**.

You should have a calculator, ruler, compasses and protractor.

The Formula Sheet is on page 2.



Formula Sheet

Volume of prism = area of cross section \times length

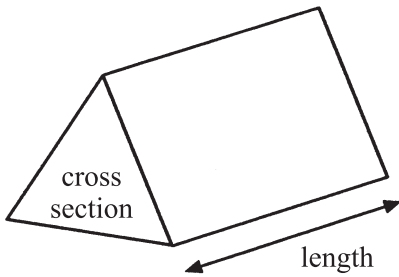

Area of trapezium = $\frac{1}{2}(a+b)h$

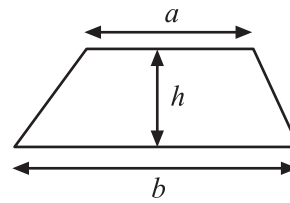

Volume of sphere = $\frac{4}{3}\pi r^3$

Surface area of sphere = $4\pi r^2$

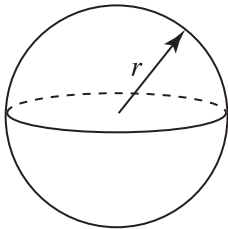

Volume of cone = $\frac{1}{3}\pi r^2 h$

Curved surface area of cone = $\pi r l$

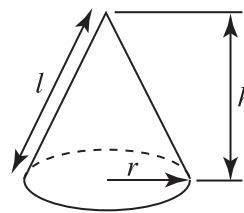

In any triangle ABC

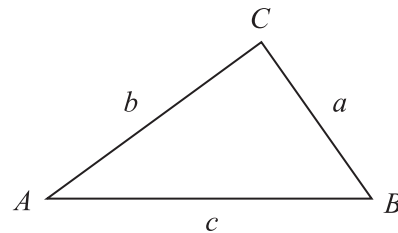

Quadratic Equation

The solutions of $ax^2 + bx + c = 0$
where $a \neq 0$, are given by

$$x = \frac{-b \pm \sqrt{b^2 - 4ac}}{2a}$$

Sine Rule: $\frac{a}{\sin A} = \frac{b}{\sin B} = \frac{c}{\sin C}$

Cosine Rule: $a^2 = b^2 + c^2 - 2bc \cos A$

Area of triangle = $\frac{1}{2} ab \sin C$



1 Divide £292 in the ratio 1:7

Answer £ _____ and £ _____ [2]

Examiner Only

Marks Remark

Total Question 1

[Turn over



2

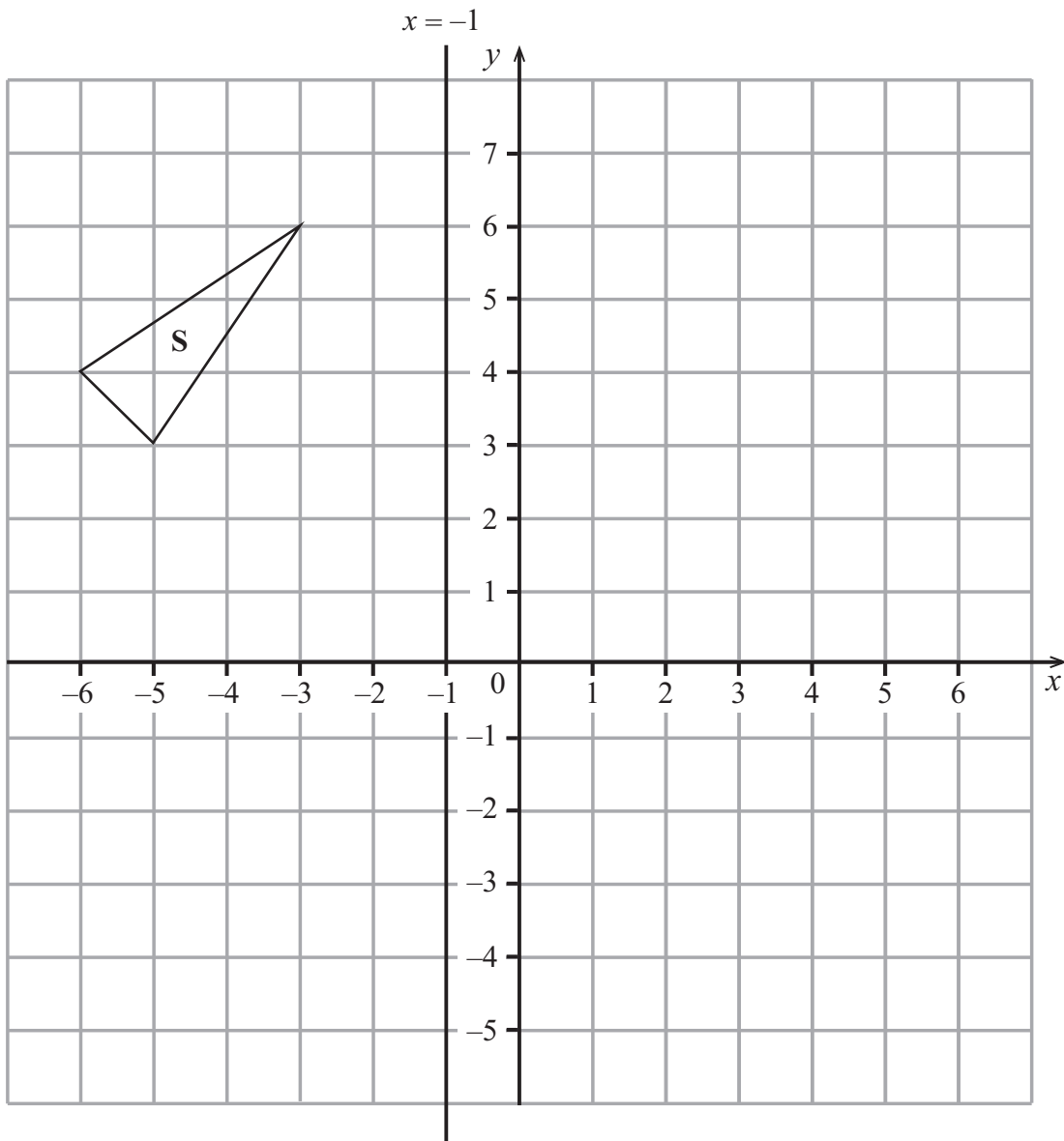

- (a) Reflect the shape S in the line $x = -1$ [1]
- (b) Draw the image of shape S after a translation 5 right and 4 down. [1]

Examiner Only	
Marks	Remark
Total Question 2	



3 (a) This spinner is a regular octagon.

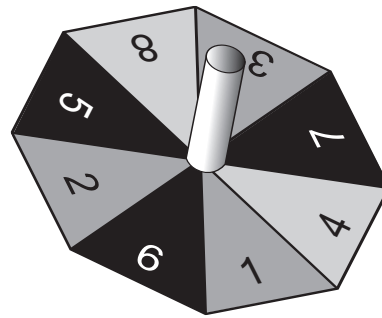

The spinner is spun 60 times.
How many times would you expect it to land on a number greater than 2?

Answer _____ [2]

(b) A box contains a number of packets of crisps of different flavours.
A packet of crisps is taken at random from the box.
Some of the probabilities of taking each flavour are shown in the table below.

Flavour	Cheese	Vinegar	Bacon	Sausage	Beef
Probability	0.3	0.12		0.25	0.05

Calculate the probability that the crisps are Bacon flavour.

Answer _____ [2]

Examiner Only

Marks Remark

Total Question 3

[Turn over



4 Three friends share a flat.
 Martin claims 1 in 20 phone calls to the flat are for him.
 Peter claims that the probability a phone call is for him is 0.4
 Noel claims 60% of the phone calls are for him.

(a) Explain why their claims cannot be correct.

_____ [1]

(b) Martin and Noel are correct.
 Calculate the probability that a phone call is for Peter.

Answer _____ [1]

Examiner Only	
Marks	Remark
Total Question 4	



- 5 Katie went on a cycling trip from her home.
The diagram below shows the distance/time graph for her complete journey.

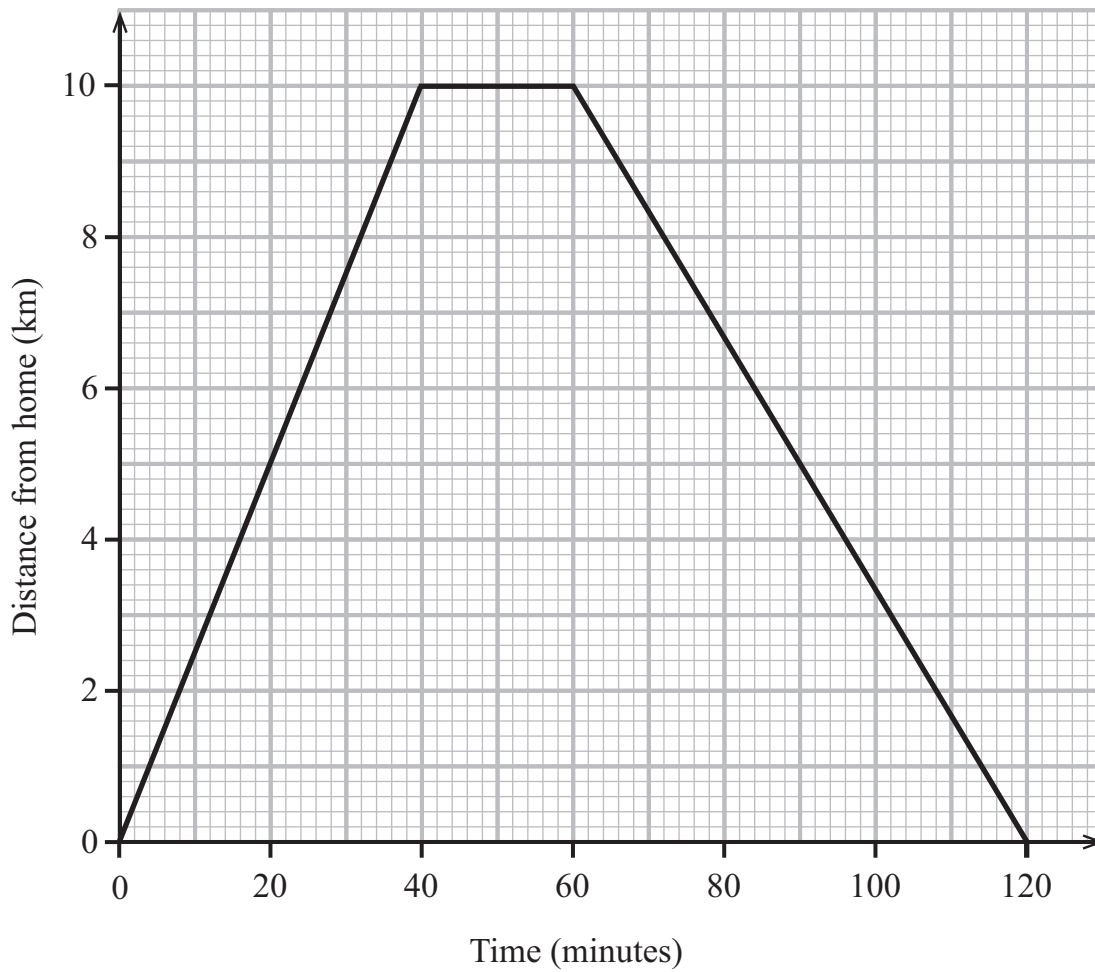

- (a) What was the average speed for the first 30 minutes?

Answer _____ km/h [1]

- (b) At what stage of the trip was she travelling at the fastest average speed?

Answer _____ [1]

- (c) After how many minutes had she travelled a distance of 14 kilometres?

Answer _____ minutes [1]

Examiner Only

Marks	Remark

Total Question 5

[Turn over



6 Work out the value of $y^2 - 4y$ when $y = -3$

Examiner Only	
Marks	Remark
Total Question 6	

Answer _____ [2]

7 A solid hexagonal prism of mass 8600 g has a cross-sectional area of 60 cm^2 and length 23 cm.

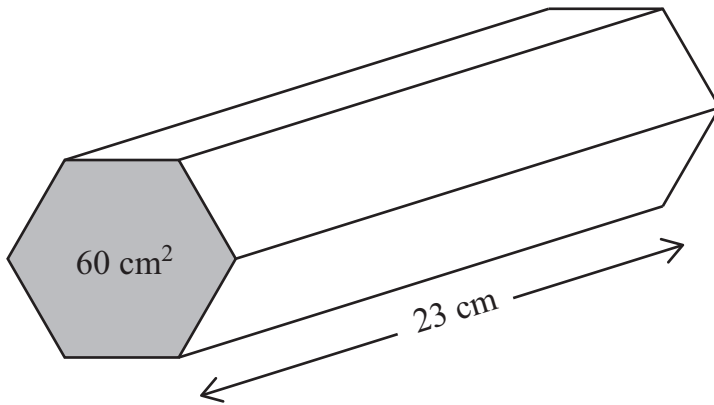

Calculate the density of the prism in g/cm^3 .

Give your answer to an appropriate degree of accuracy.

Total Question 7	

Answer _____ g/cm^3 [4]



8 (a) Solve the inequality $5x + 4 > 11$

Answer _____ [2]

(b) Illustrate your answer to part (a) on the number line below.

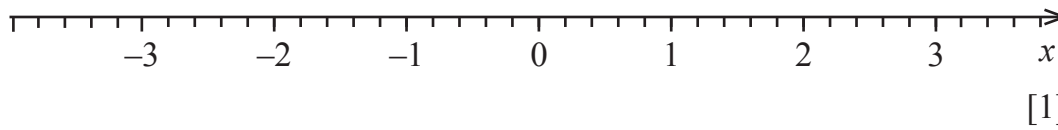

Examiner Only

Marks Remark

Total Question 8

[Turn over



Quality of written communication will be assessed in this question.

- 10** In a school there are 340 pupils, of which 180 are boys.
 The total number of pupils in the Sports Club is 164
 The probability that a boy is a member of the Sports Club is 0.6
 Calculate the probability that a girl in the school is a member of the Sports Club.

Examiner Only	
Marks	Remark
Total Question 10	

Answer _____ [4]

[Turn over



- 11 The probability that I stay up late on a Saturday night is $\frac{3}{4}$
When I stay up late, the probability that I lie in on Sunday morning is $\frac{2}{3}$
When I do not stay up late on Saturday night, then the probability that I lie in on Sunday morning is $\frac{1}{5}$

(a) Complete the tree diagram.

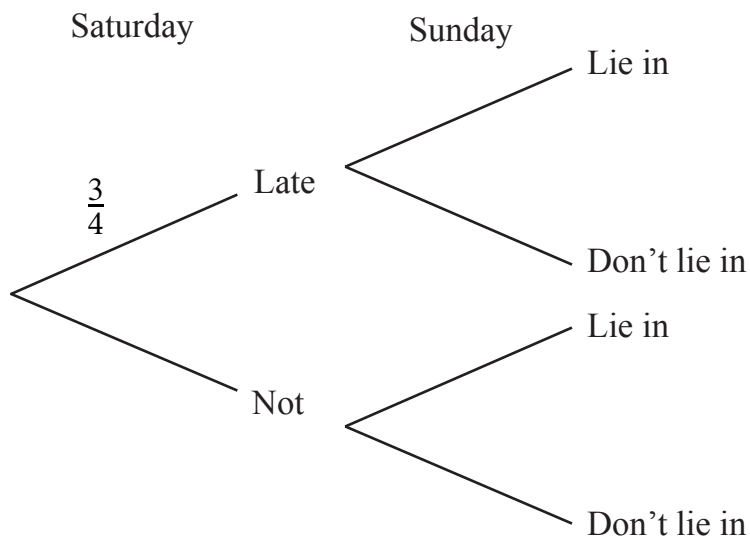

[2]

(b) Calculate the probability that I lie in on a Sunday morning.

Answer _____ [2]

Examiner Only	
Marks	Remark
Total Question 11	



- 12 (a) On the grid below, show by shading **and the letter R**, the region which satisfies all the inequalities.

$$x \geq 1$$

$$y \geq x$$

$$x + 2y \leq 6$$

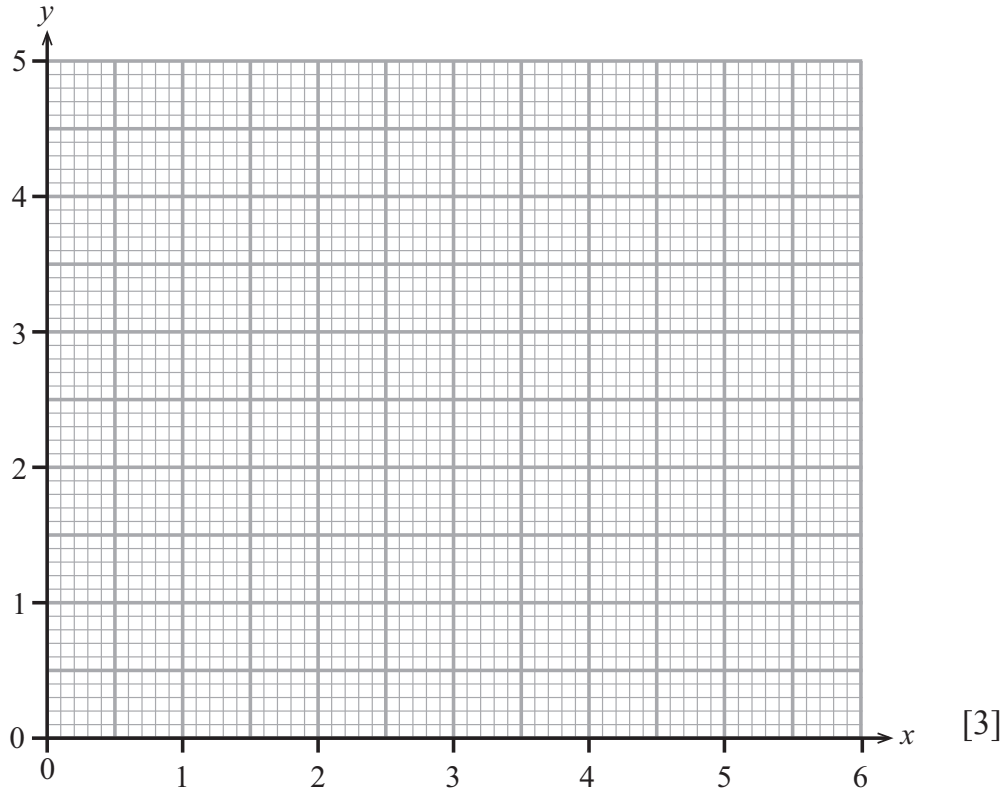

- (b) Work out the greatest value of $2x + y$ in the region R above.

Answer _____ [2]

Examiner Only	
Marks	Remark
Total Question 12	
Total Question 13	

- 13 (a) Write 0.0000473 in standard form.

Answer _____ [1]

- (b) Write 3.6×10^{-12} in decimal form.

Answer _____ [1]

[Turn over



14 Rationalise the denominator of $\frac{10}{\sqrt{5}}$

Examiner Only	
Marks	Remark
Total Question 14	

Answer _____ [2]

15 The diagram below shows a large cone of radius 4 cm and height 12 cm and a small cone with height h .

The volume of the large cone is three times the volume of the small cone.

Calculate the height h of the small cone.

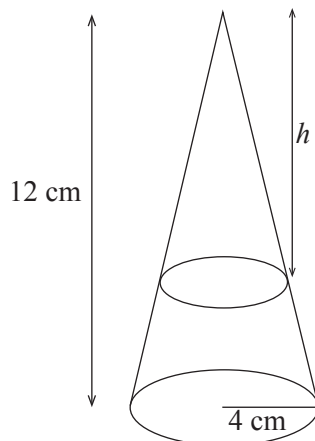

Total Question 15	

Answer $h =$ _____ cm [4]



16 Prove that $\frac{p+r}{pr} - \frac{p+q}{pq} \equiv \frac{q-r}{qr}$

[4]

THIS IS THE END OF THE QUESTION PAPER

Examiner Only

Marks Remark

Total Question 16



DO NOT WRITE ON THIS PAGE

For Examiner's use only	
Question Number	Marks
1	
2	
3	
4	
5	
6	
7	
8	
9	
10	
11	
12	
13	
14	
15	
16	

Total Marks	
--------------------	--

Examiner Number

Permission to reproduce all copyright material has been applied for.
In some cases, efforts to contact copyright holders may have been unsuccessful and CCEA will be happy to rectify any omissions of acknowledgement in future if notified.

