

Surname					Other Names				
Centre Number					Candidate Number				
Candidate Signature									

Leave blank

General Certificate of Secondary Education
June 2003



MATHEMATICS (MODULAR) (SPECIFICATION B) 33005/F1
Module 5 Foundation Tier
Paper 1 Non-Calculator

F

Wednesday 4 June 2003 1.30 pm to 2.30 pm

<p>In addition to this paper you will require: mathematical instruments. You must not use a calculator.</p>	
---	--

For Examiner's Use	
Pages	Mark
3	
4 – 5	
6 – 7	
8 – 9	
10 – 11	
12 – 13	
14 – 15	
16	
TOTAL	
Examiner's Initials	

Time allowed: 1 hour

Instructions

- Use blue or black ink or ball-point pen. Draw diagrams in pencil.
- Fill in the boxes at the top of this page.
- Answer **all** questions in the spaces provided.
- Do all rough work in this booklet.

Information

- The maximum mark for this paper is 60.
- Mark allocations are shown in brackets.
- Additional answer paper, graph paper and tracing paper will be issued on request and must be tagged securely to this answer booklet.

Advice

- In all calculations, show clearly how you work out your answer.

Formula Sheet: Foundation Tier

You may need to use the following formula:

Area of trapezium $= \frac{1}{2}(a+b)h$

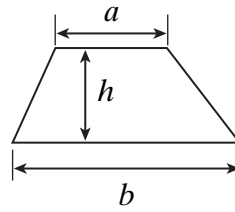

Answer **all** questions in the spaces provided.

1 Here is a bus route and a fares table.

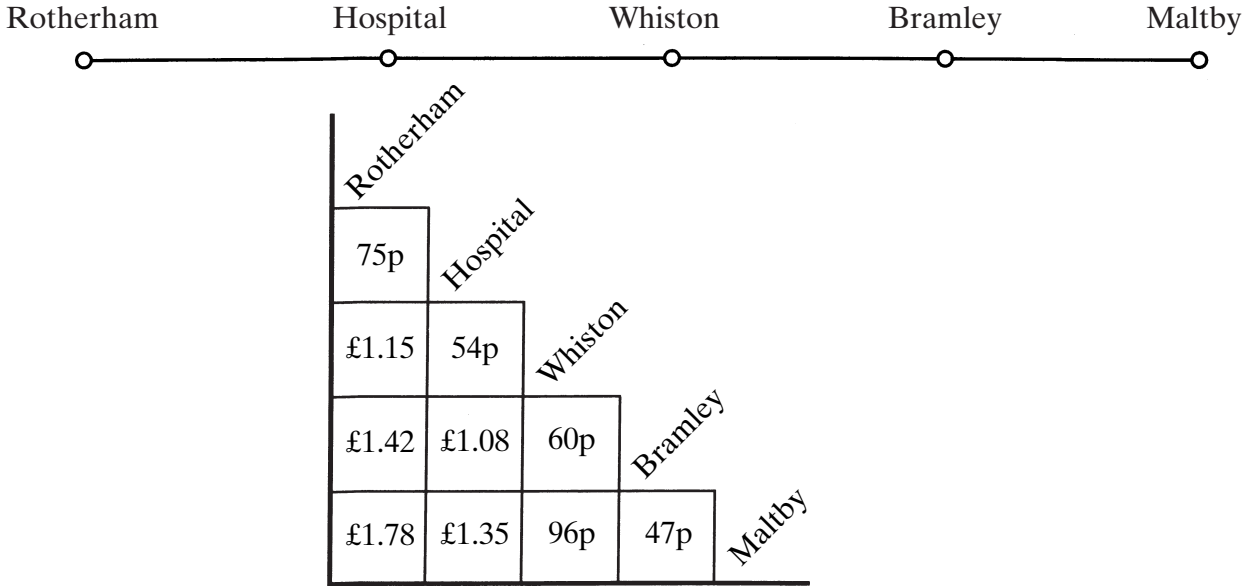

(a) How much is the bus fare from the Hospital to Maltby?

Answer £ (1 mark)

(b) Jon travels to Rotherham from Bramley.
He pays with a £5 note.

How much change does he receive?

.....

Answer £ (2 marks)

(c) A child pays 35p for any journey.

What is the total cost for an adult and two children to travel from Bramley to Maltby?

.....

Answer £ (2 marks)

Turn over ▶

2 Patterns are made of sticks.

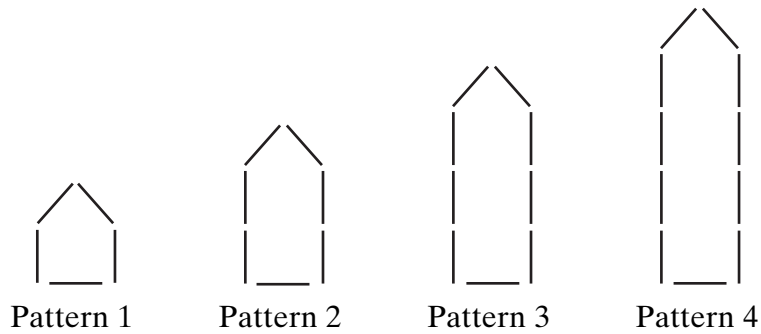

(a) Complete the table for Pattern 4.

Pattern number	1	2	3	4
Number of sticks	5	7	9	

(1 mark)

(b) Sketch Pattern 5.

(1 mark)

(c) Which pattern will have 25 sticks?

.....

.....

Answer *(2 marks)*

(d) Here is the rule for working out the number of sticks.

Multiply pattern number by 2 and add 3

How many sticks will be in Pattern 100?

.....

Answer *(1 mark)*

- 3 A rectangular box has length 4 cm, width 3 cm and height 2 cm.
The box is to be filled with centimetre cubes.

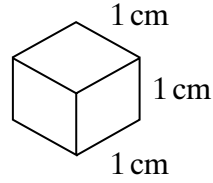
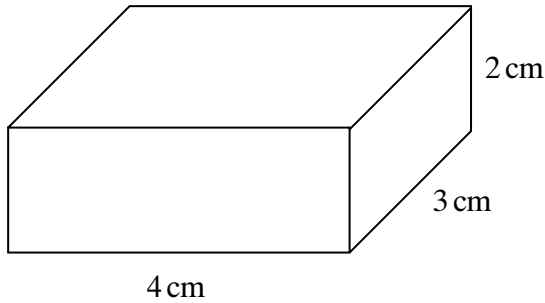

Not to scale

- (a) How many centimetre cubes are needed to fill the box?

.....
.....

Answer cubes (2 marks)

- (b) Write down the volume of the box.

Answer (1 mark)

TURN OVER FOR THE NEXT QUESTION

Turn over ►

- 4 The points P , Q and R are plotted on the grid to form a triangle.

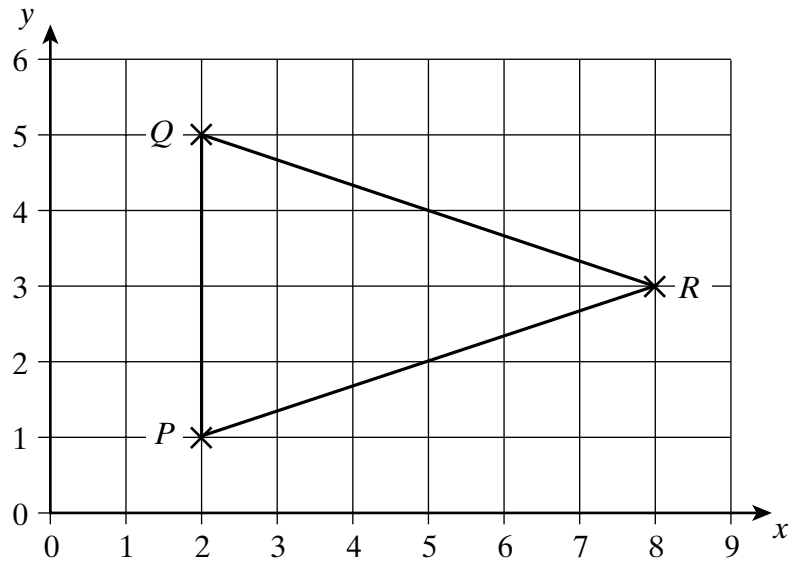

- (a) What is the mathematical name given to triangle PQR ?

Answer (1 mark)

- (b) (i) Mark the mid-point of PQ on the grid.
Label it M .

(1 mark)

- (ii) Write down the coordinates of M .

Answer (.....,) (1 mark)

- 5 A speed limit in France is 100 kilometres per hour.
The speedometer shows the speed of a lorry.

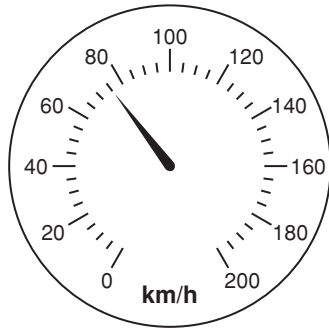

- (a) How much slower than the speed limit is the lorry travelling?

.....
.....

Answer km/h (2 marks)

- (b) (i) Use the graph to convert 32 kilometres per hour into miles per hour.

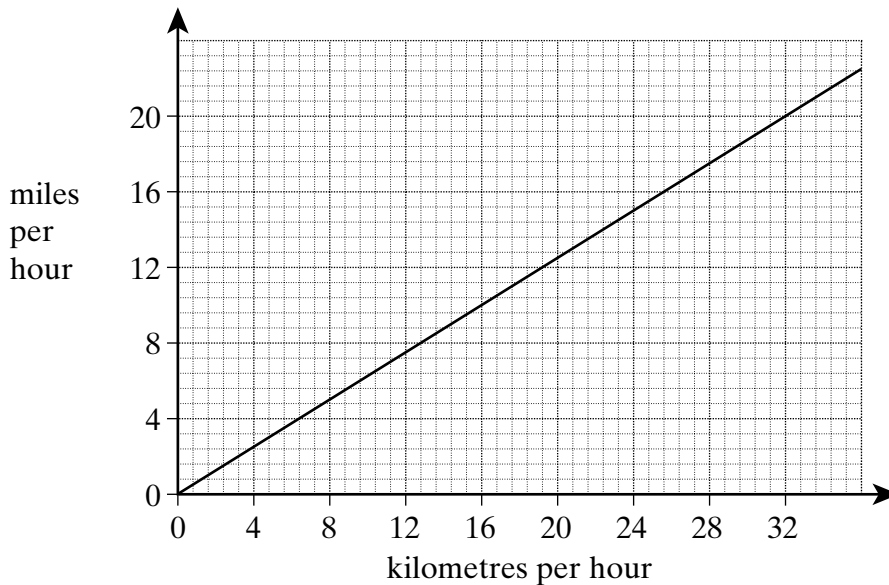

Answer miles per hour (1 mark)

- (ii) Convert 96 kilometres per hour into miles per hour.

.....
.....

Answer miles per hour (2 marks)

Turn over ▶

6 (a) Here are six rectangles on a centimetre grid.

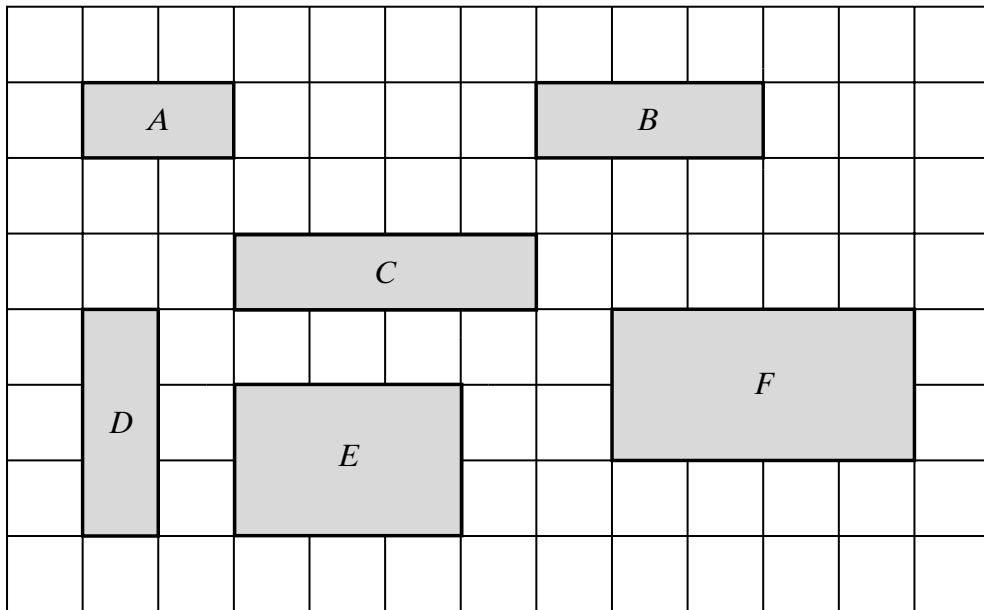

(i) Which two rectangles are congruent?

Answer and (1 mark)

(ii) Which two rectangles are similar?

Answer and (1 mark)

(b) Triangle *H* is an enlargement of triangle *G*.

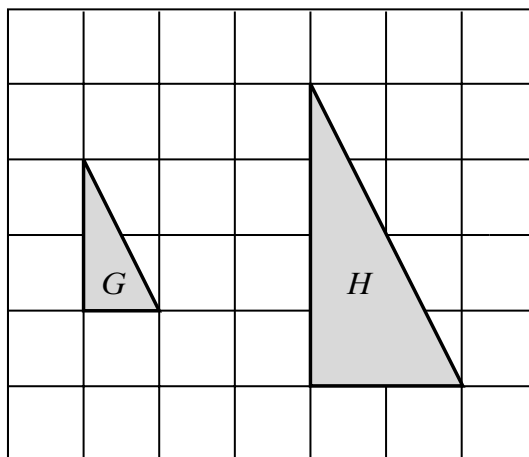

State the scale factor of the enlargement.

Answer (1 mark)

7 (a) Here is a list of angles.

8° 42° 90° 97° 132° 205° 281° 333°

From the list, write down an angle which is

(i) obtuse,

Answer degrees (1 mark)

(ii) reflex.

Answer degrees (1 mark)

(b) The diagram shows a hexagon.
The hexagon has two lines of symmetry as shown.

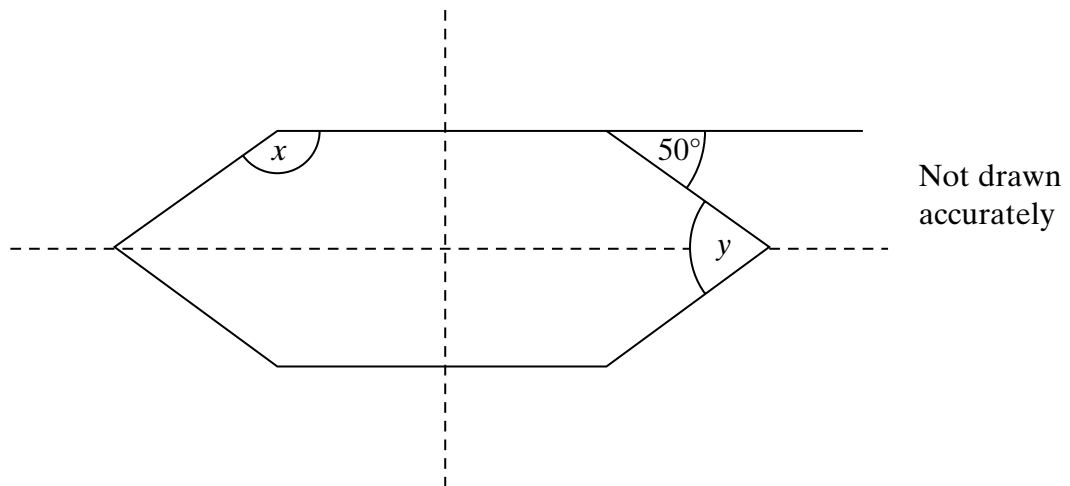

(i) Work out the value of x .

.....

Answer degrees (1 mark)

(ii) Work out the value of y .

.....

Answer degrees (2 marks)

Turn over ►

8 A printing machine prints 8 pages per minute.

(a) How long will it take to print 1000 pages?
Give your answer in hours and minutes.

.....
.....
.....
.....

Answer hours minutes (3 marks)

(b) A new machine prints 25% more pages per minute.

How many pages will the new machine print in 1 hour?

.....
.....
.....
.....

Answer pages (3 marks)

9 (a) Write down the square root of 49.

.....

Answer (1 mark)

(b) Work out the value of 10^4

.....

Answer (1 mark)

10 (a) Find the value of $3x + 4y$

(i) when $x = 2$ and $y = 5$

.....
.....

Answer (2 marks)

(ii) when $x = 6$ and $y = -3$

.....
.....

Answer (2 marks)

(b) Find the value of $a^3 + b^2$ when $a = 2$ and $b = 5$

.....
.....
.....

Answer (2 marks)

TURN OVER FOR THE NEXT QUESTION

Turn over 

- 11 The length of a rectangle is twice its width.

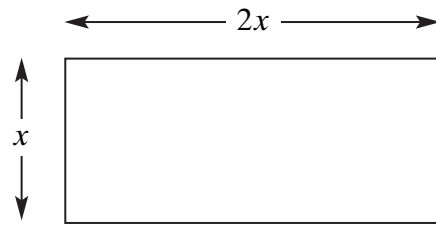

Not to scale

The area of the rectangle is 50 cm^2 .

- (a) Show that the length of the rectangle is 10 cm.

.....

 (1 mark)

- (b) Work out the perimeter of the rectangle.

.....

 Answer cm (1 mark)

- 12** The diagram shows the positions of *A* and *B*.
The diagram is drawn to scale.
1 cm represents 10 km.

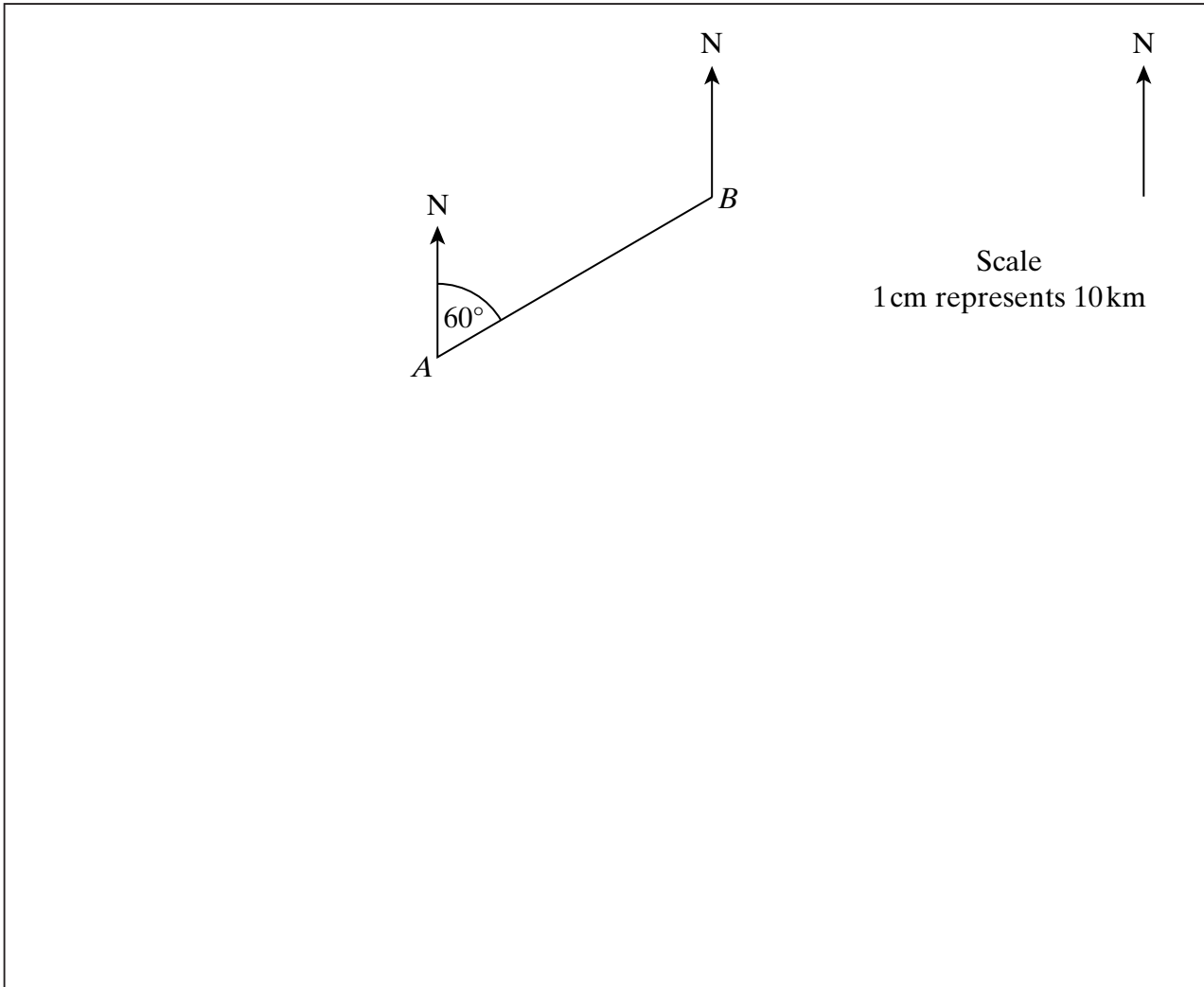

- (a) Use the diagram to calculate the actual distance of *B* from *A*.

.....
.....

Answer km (2 marks)

- (b) *C* is due south of *B*.

- (i) Write down the three figure bearing of *C* from *B*.

Answer ° (1 mark)

- (ii) *C* is also on a bearing of 150° from *A*.

Mark the position of *C* on the diagram.

(2 marks)

Turn over ►

7

13 (a) Paul thinks that when an even number is halved the answer is always even.

Give an example to show that Paul is wrong.

.....
.....

(1 mark)

(b) p is an odd number.

Is $2p + 1$ an odd number, an even number or could it be either?

Tick the correct box.

odd

even

either

(1 mark)

14 In a test Adam scored 10 more marks than Rachael.
Altogether they scored 62 marks.

Find Adam's score.

.....
.....
.....
.....
.....
.....

Answer marks (3 marks)

15 The diagram shows two identical shapes A and B .

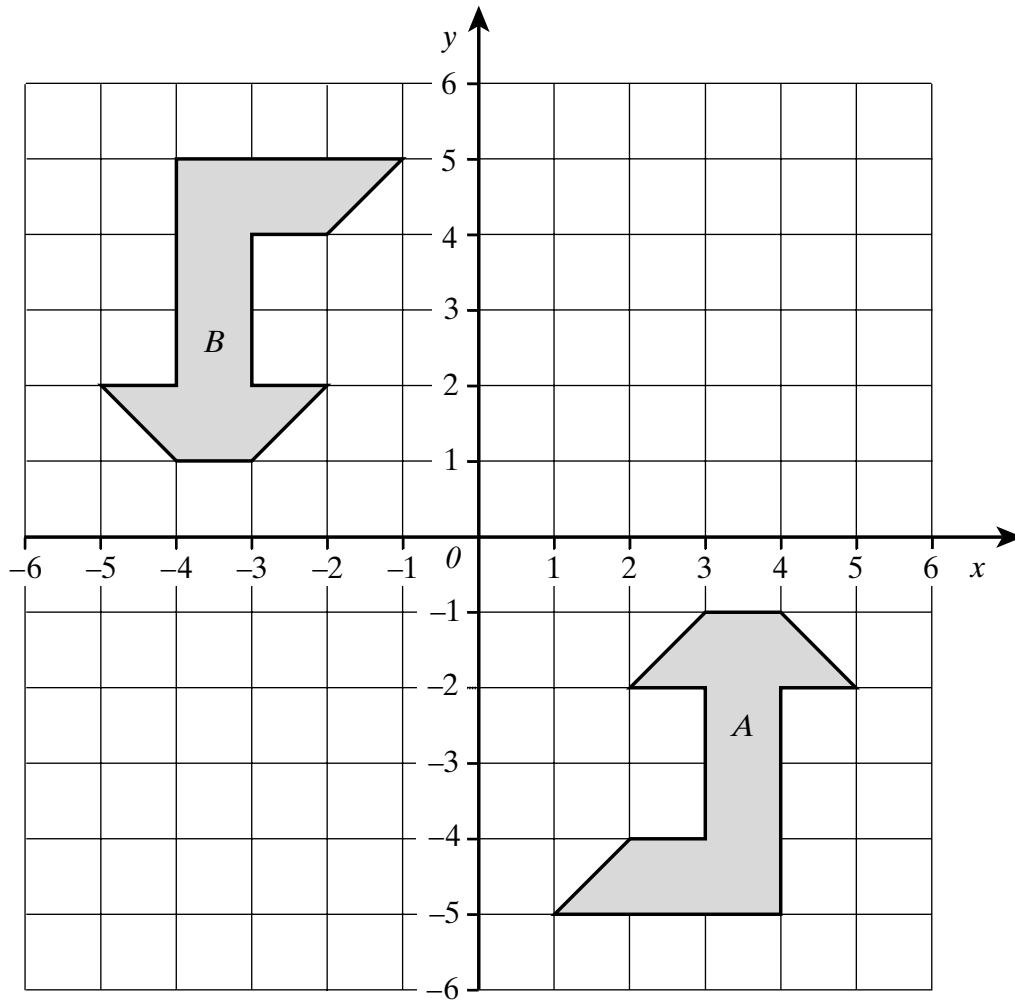

Describe fully the **single** transformation which takes shape A to shape B .

.....

.....

(3 marks)

Turn over ►

16 The diagram represents a solid made from 9 small cubes.

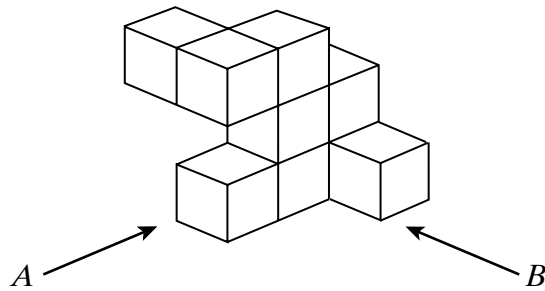

The view of the solid from direction *A* is shown below.

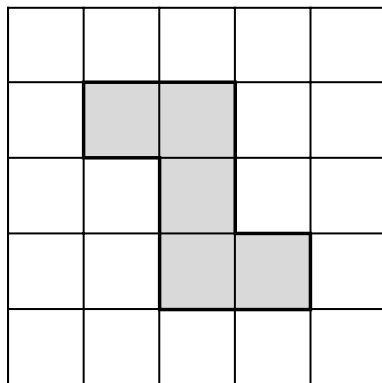

On the grid below, draw the view of the solid from direction *B*.

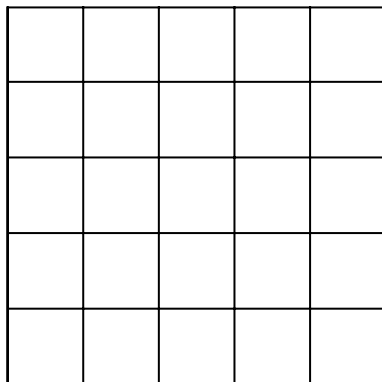

(2 marks)

END OF QUESTIONS