

GCSE Mathematics Specification (8300/1F)

F

Paper 1 Foundation tier

Date

Morning

1 hour 30 minutes

Materials

For this paper you must have:

- mathematical instruments

You must **not** use a calculator



Instructions

- Use black ink or black ball-point pen. Draw diagrams in pencil.
- Fill in the boxes at the bottom of this page.
- Answer **all** questions.
- You must answer the questions in the spaces provided. Do not write outside the box around each page or on blank pages.
- Do all rough work in this book.
- In all calculations, show clearly how you work out your answer.

Information

- The marks for questions are shown in brackets.
- The maximum mark for this paper is 80.
- You may ask for more answer paper, graph paper and tracing paper. These must be tagged securely to this answer book.

Please write clearly, in block capitals, to allow character computer recognition.

Centre number Candidate number

Surname

Forename(s)

Candidate signature _____

Answer **all** questions in the spaces provided.

- 1 How many centimetres are there in 3.7 metres?
Circle your answer.

[1 mark]

0.037

0.37

37

370

- 2 Which of these is the **net** of a **cube**?
Circle the correct letter.

[1 mark]

A

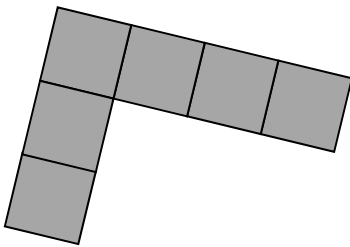

B

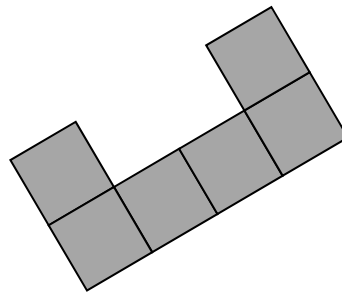

C

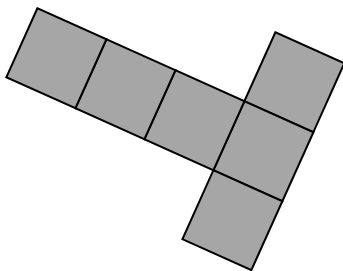

D

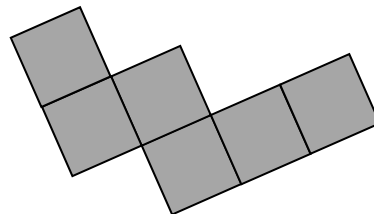

3 Circle the fraction that is **not** equivalent to $\frac{3}{8}$

[1 mark]

$$\frac{6}{16}$$

$$\frac{9}{24}$$

$$\frac{12}{32}$$

$$\frac{15}{35}$$

4 Simplify $5a - (2a + 6)$

Circle your answer.

[1 mark]

$$3a + 6$$

$$9a$$

$$-3a$$

$$3a - 6$$

Turn over for the next question

5 Complete the table.

[2 marks]

Minutes	Hours
30	$\frac{1}{2}$
40	
	$2\frac{1}{4}$

6 Here are some numbers.

9.6

12.6

15.4

7.6

12.4

17.4

Write the numbers in pairs so that the **sum** of the numbers in each pair is the same.

[2 marks]

Answer _____ and _____

_____ and _____

_____ and _____

7 This triangle is drawn accurately.

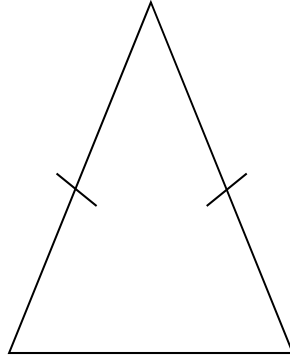

What type of triangle is it?

Tick **two** boxes.

[1 mark]

acute-angled

obtuse-angled

equilateral

isosceles

scalene

Turn over for the next question

8 Work out 51% of 400

[2 marks]

Answer _____

9 Write 180 g as a fraction of 3 kg
Give your answer in its simplest form.

[2 marks]

Answer _____

10 Here are some properties of numbers.

- A Even
- B Odd
- C Prime
- D Square
- E Two-digit

10 (a) Which **two** properties does the number 4 have?

Circle the correct letters.

[1 mark]

A B C D E

10 (b) Can one number have **all** of the properties?

Tick a box.

Yes

No

Cannot tell

Give a reason for your answer.

[1 mark]

10 (c) Write down a number with **three** of the properties.

State which properties it has.

[2 marks]

Number _____

Properties _____, _____, _____

Turn over ►

11 Ranjit has six coins in his pocket.

If he picks **five** of the coins

the most he could pick is £4.60

the least he could pick is £2.70

How much money does he have altogether?

[4 marks]

Answer £ _____

12 Here are three expressions.

$$\frac{b}{a}$$

$$a - b$$

$$ab$$

When $a = 2$ and $b = -6$ which expression has the smallest value?

You **must** show your working.

[2 marks]

Answer _____

Turn over for the next question

- 13** The table shows the ratio of teachers to children needed for two activities.

	teachers : children
Climbing	1 : 4
Walking	1 : 9

- 13 (a)** There are 7 teachers to take children climbing.

What is the greatest number of children that can go climbing?

[1 mark]

Answer _____

- 13 (b)** 49 children want to go walking.

What is the smallest number of teachers needed?

[1 mark]

Answer _____

14

Shape R is a rectangle.

A smaller rectangle is cut from R to form shape L .

Not drawn
accurately

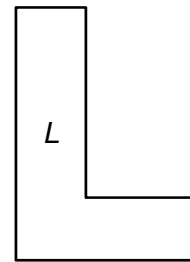
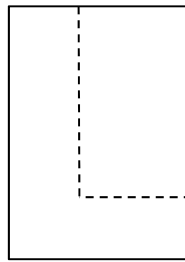
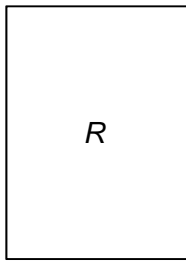

Which **one** of these statements is true?

Tick a box.

The perimeter of R is **longer than** the perimeter of L

The perimeter of R is the **same as** the perimeter of L

The perimeter of R is **shorter than** the perimeter of L

It is **not** possible to tell which perimeter is longer

[1 mark]

Turn over for the next question

15 Textbooks are stored on two shelves.

Each shelf is 0.72 metres long.

Each textbook is 30 millimetres wide.

Not drawn
accurately



Can 50 textbooks be stored on these shelves?

You **must** show your working.

[3 marks]

Answer _____

16 All tickets for a concert are the same price.

Amy and Dan pay £63 altogether for some tickets.

Amy pays £24.50 for 7 tickets.

How many tickets does Dan buy?

[4 marks]

Answer _____

- 17 Here is the graph of $y = 5 - x$ for values of x from 0 to 5

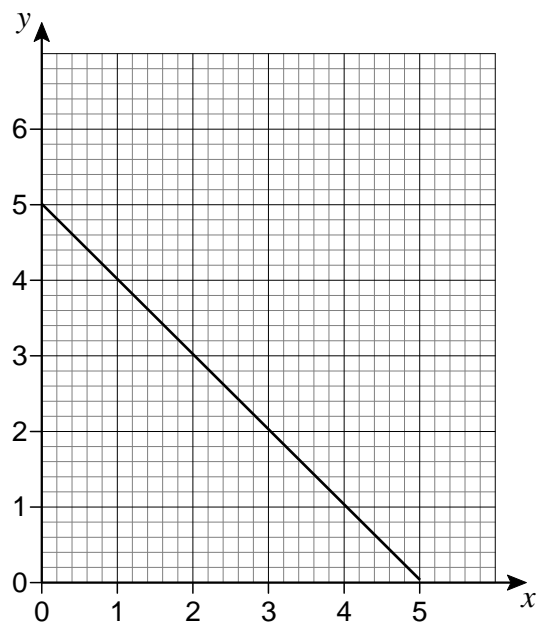

- 17 (a) On the same grid, draw the graph of $y = x + 1$ for values of x from 0 to 5

[2 marks]

- 17 (b) Use the graphs to solve the simultaneous equations

$$y = 5 - x \quad \text{and} \quad y = x + 1$$

[1 mark]

$$x = \underline{\hspace{10em}}$$

$$y = \underline{\hspace{10em}}$$

- 18 The table shows the sales of food and drink for three days at a market stall.

Day	Sales of food (£)	Sales of drink (£)
Thursday	34	16
Friday	22	48
Saturday	46	28

Hannah uses this information to draw a composite bar chart.

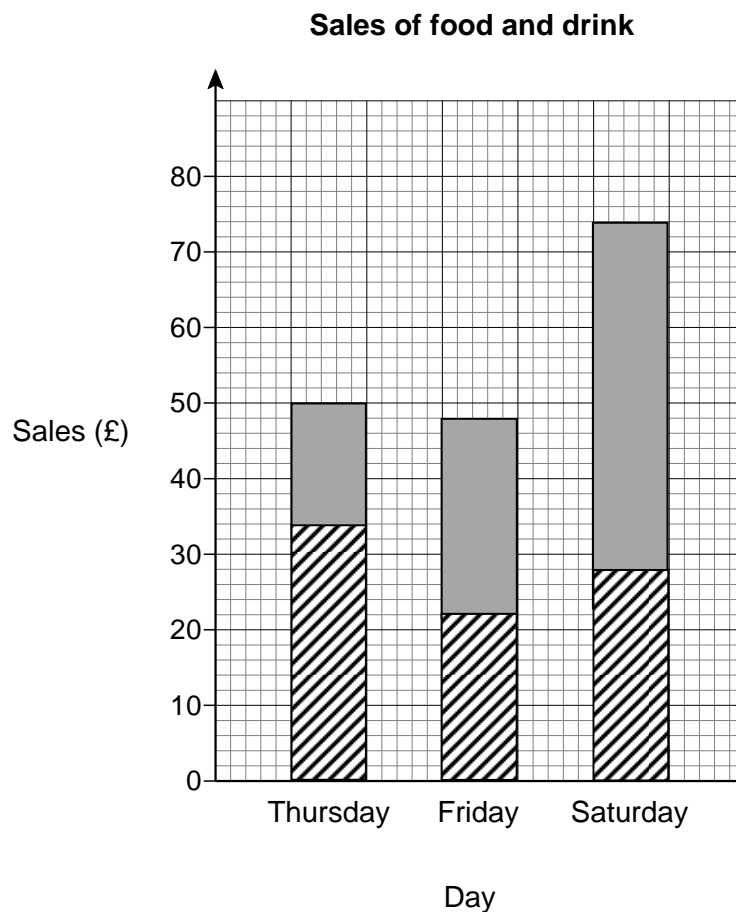

Write down **three** different mistakes that she has made.

[3 marks]

Mistake 1 _____

Mistake 2 _____

Mistake 3 _____

19 Sam wants to buy a camera for £345

He has already saved £96

Each week

his pay is £80

he saves 30% of this pay.

How many **more** weeks must he save?

[4 marks]

Answer _____ weeks

20 (a) w and x are **whole** numbers.

$$w > 40$$

$$x < 30$$

Work out the **smallest** possible value of $w - x$

[2 marks]

Answer _____

20 (b) y and z are **whole** numbers.

$$y < 60$$

$$z \leq 50$$

Work out the **largest** possible value of $y + z$

[2 marks]

Answer _____

21 (a) Work out 2.4×0.002

[1 mark]

Answer _____

21 (b) Write 1.2×10^{-5} as an ordinary number.

[1 mark]

Answer _____

21 (c) Write 2 500 000 in standard form.

[1 mark]

Answer _____

Turn over for the next question

- 22 The diagram shows information about the scores of Class 3A in a spelling test.

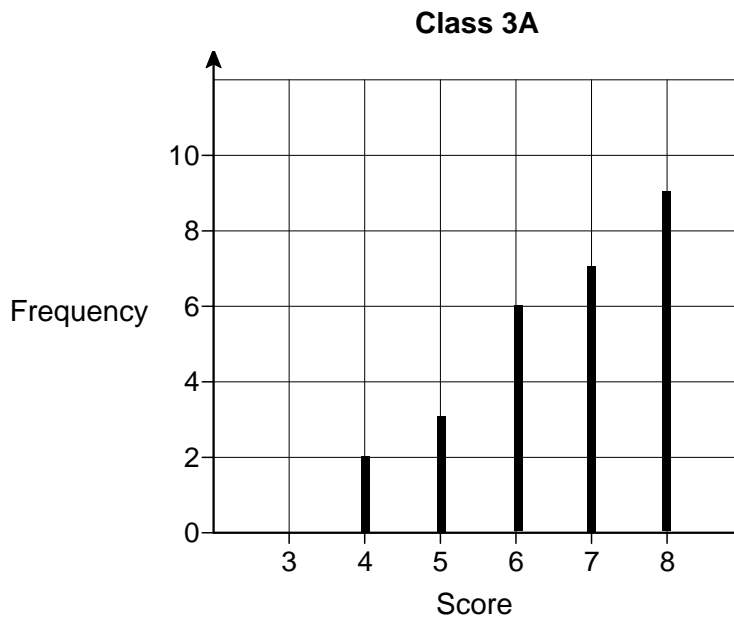

- 22 (a) A student is chosen at random from Class 3A.

Work out the probability that the student's score was the **mode** for the class.

[3 marks]

Answer _____

The diagram shows information about the scores of Class 3B in the same test.

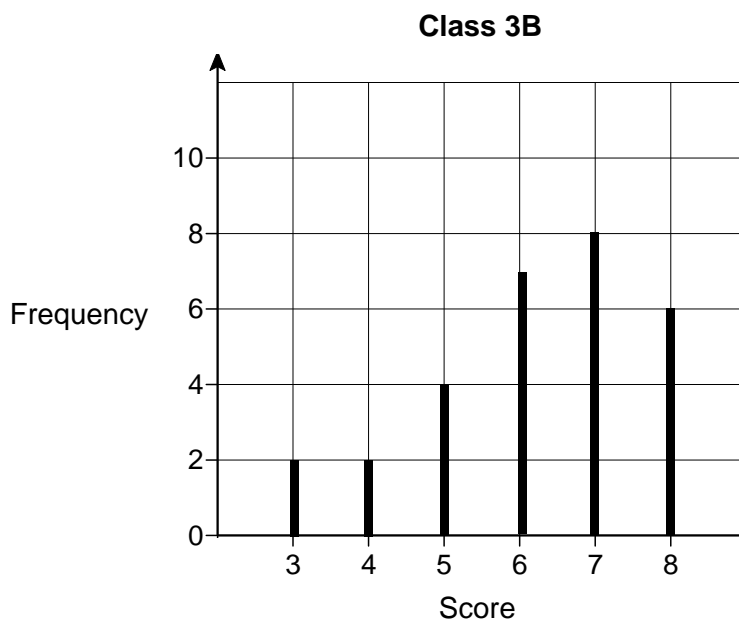

22 (b) Show that Class 3A had more **consistent** scores than Class 3B.

Use the data from both diagrams.

[2 marks]

22 (c) Lucy is one of the 29 students in **Class 3B**.

Her score was the same as the **median** score for her class.

Work out her score.

[2 marks]

Answer _____

- 23 Kelly is trying to work out the two values of w for which $3w - w^3 = 2$
Her values are 1 and -1

Are her values correct?

You **must** show your working.

[2 marks]

- 24 The diagram shows a semicircle of radius 8 cm

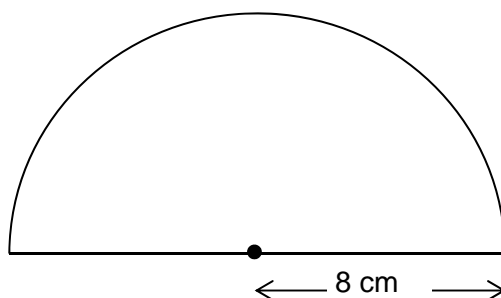

Not drawn
accurately

Work out the area of the semicircle.

Give your answer in terms of π .

[2 marks]

Answer _____ cm^2

25 Work out $2\frac{3}{4} \times 1\frac{5}{7}$

Give your answer as a mixed number in its simplest form.

[3 marks]

Answer _____

26 Solve $5x - 2 > 3x + 11$

[2 marks]

Answer _____

Turn over for the next question

- 27 The n th term of a sequence is $2n + 1$
The n th term of a different sequence is $3n - 1$

Work out the **three** numbers that are

in both sequences

and

between 20 and 40

[3 marks]

Answer _____, _____, _____

- 28** White paint costs £2.80 per litre.
Blue paint costs £3.50 per litre.
White paint and blue paint are mixed in the ratio 3 : 2

Work out the cost of 18 litres of the mixture.

[4 marks]

Answer £ _____

Turn over for the next question

29 Here are sketches of four triangles.

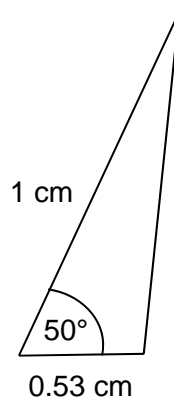
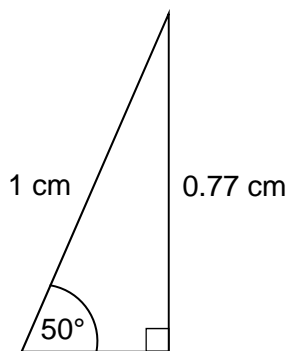

Not drawn accurately

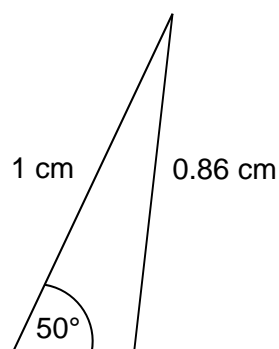
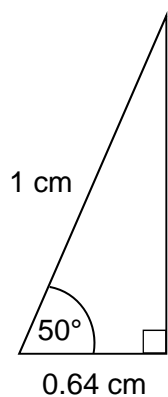

In each triangle

the longest side is **exactly** 1 cm

the other length is given to 2 decimal places.

29 (a) Circle the value of $\cos 50^\circ$ to 2 decimal places.

[1 mark]

0.77

0.53

0.64

0.86

- 29 (b)** Work out the value of x .
Give your answer to 1 decimal place.

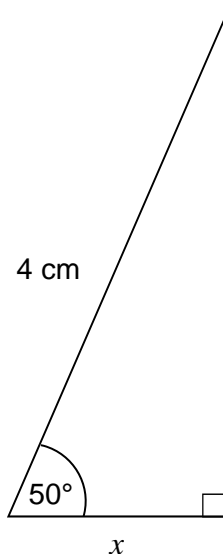

Not drawn
accurately

[2 marks]

Answer _____ cm

Turn over for the next question

- 30** $ABCH$ is a square.
 $HCFG$ is a rectangle.
 $CDEF$ is a square.

They are joined to make an L-shape.

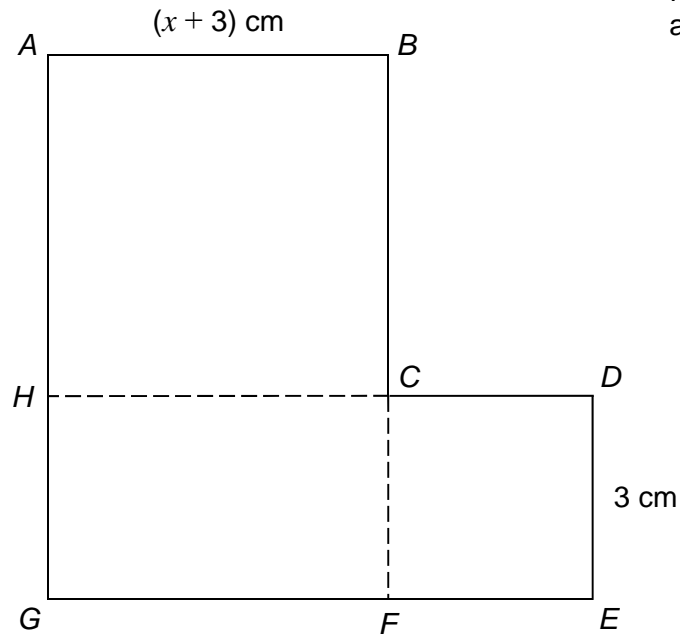

Not drawn accurately

Show that the total area of the L-shape, in cm^2 , is $x^2 + 9x + 27$

[4 marks]

END OF QUESTIONS

GCSE Mathematics Specification (8300/1H)

H

Paper 1 Higher tier

Date

Morning

1 hour 30 minutes

Materials

For this paper you must have:

- mathematical instruments

You must **not** use a calculator



Instructions

- Use black ink or black ball-point pen. Draw diagrams in pencil.
- Fill in the boxes at the bottom of this page.
- Answer **all** questions.
- You must answer the questions in the spaces provided. Do not write outside the box around each page or on blank pages.
- Do all rough work in this book.
- In all calculations, show clearly how you work out your answer.

Information

- The marks for questions are shown in brackets.
- The maximum mark for this paper is 80.
- You may ask for more answer paper, graph paper and tracing paper. These must be tagged securely to this answer book.

Please write clearly, in block capitals, to allow character computer recognition.

Centre number

Candidate number

Surname

Forename(s)

Candidate signature _____

Answer **all** questions in the spaces provided.

- 1** Circle the calculation that increases 400 by 7% **[1 mark]**

400×0.07

400×0.7

400×1.07

400×1.7

- 2** Simplify $3^4 \times 3^4$
Circle the answer. **[1 mark]**

3^8

9^8

3^{16}

9^{16}

- 3** Circle the area that is the same as 5.5 m^2 **[1 mark]**

550 cm^2

$5\,500 \text{ cm}^2$

$55\,000 \text{ cm}^2$

$5\,500\,000 \text{ cm}^2$

4 One of these graphs is a sketch of $y = 1 - 2x$

Which one?

Circle the correct letter.

[1 mark]

A

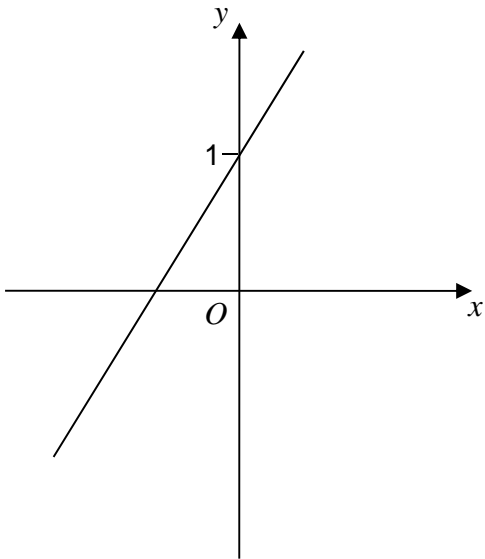

B

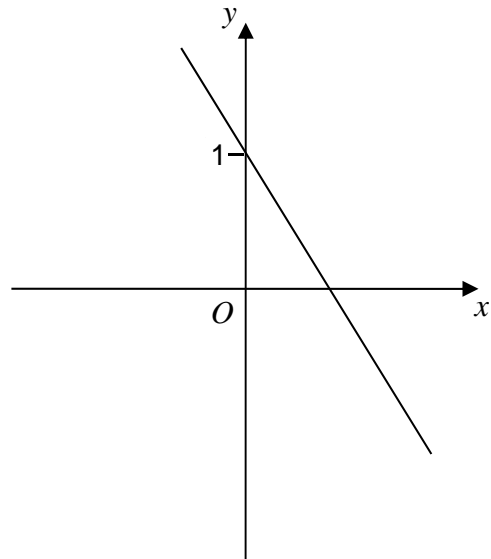

C

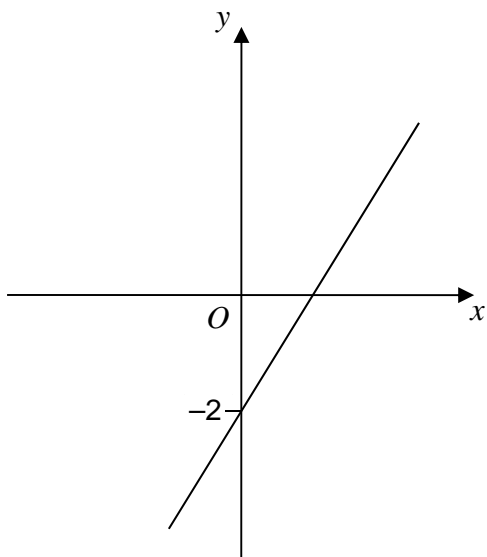

D

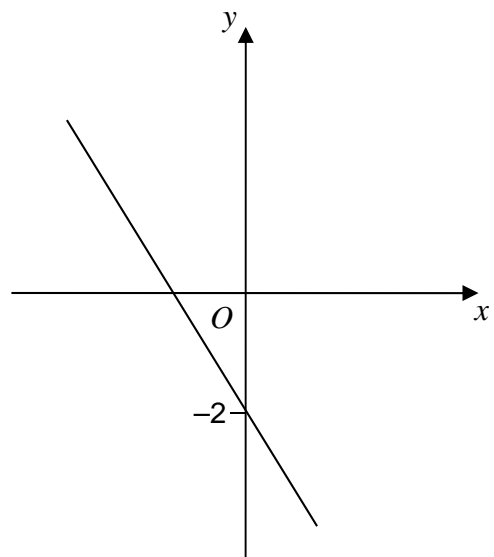

- 5 The scatter graph shows the age and the price of 18 cars.
The cars are all the same make and model.

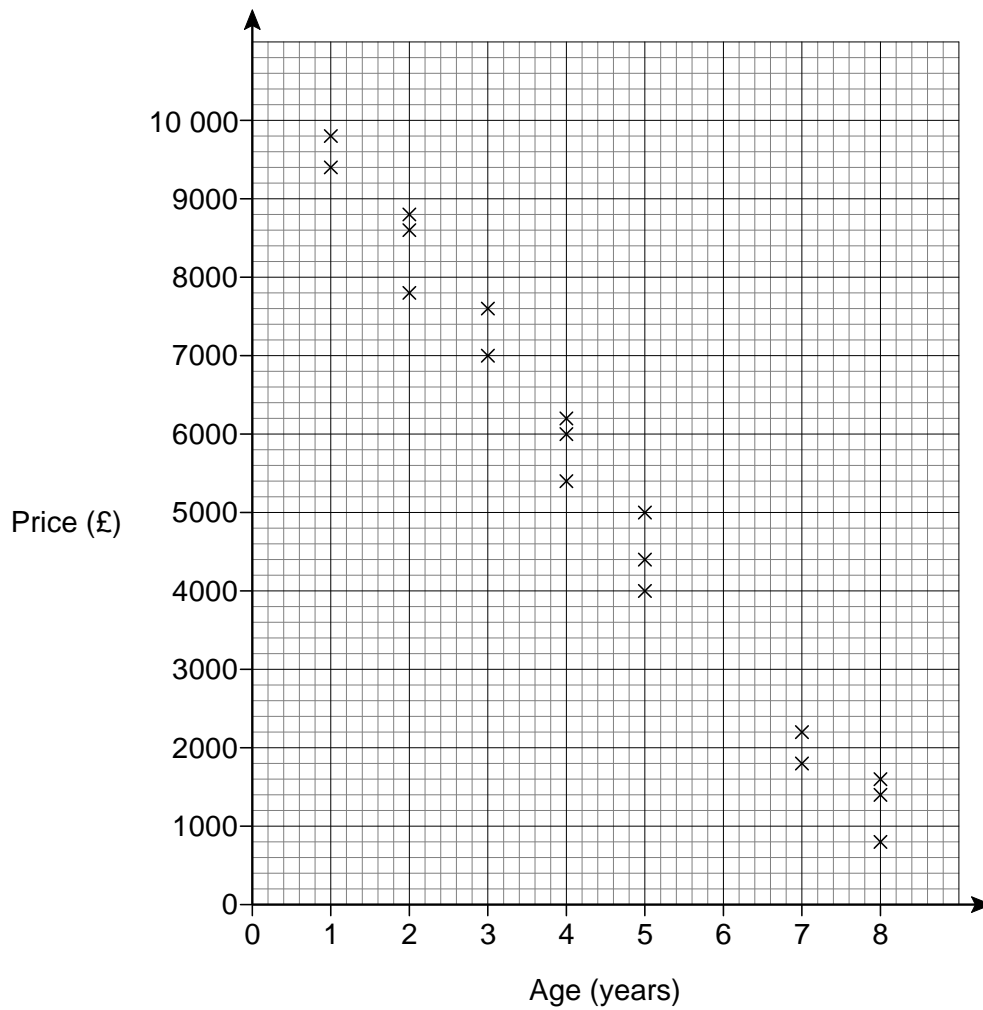

Use a line of best fit to estimate the price of a 6-year old car.

[2 marks]

Answer £ _____

- 6 Kelly is trying to work out the two values of w for which $3w - w^3 = 2$
Her values are 1 and -1

Are her values correct?

You **must** show your working.

[2 marks]

- 7 Work out $2\frac{3}{4} \times 1\frac{5}{7}$

Give your answer as a mixed number in its simplest form.

[3 marks]

Answer _____

8 Solve $5x - 2 > 3x + 11$

[2 marks]

Answer _____

9 The n th term of a sequence is $2n + 1$
The n th term of a different sequence is $3n - 1$

Work out the **three** numbers that are

in both sequences

and

between 20 and 40

[3 marks]

Answer _____, _____, _____

- 10** White paint costs £2.80 per litre.
Blue paint costs £3.50 per litre.
White paint and blue paint are mixed in the ratio 3 : 2

Work out the cost of 18 litres of the mixture.

[4 marks]

Answer £ _____

Turn over for the next question

- 11 Students in a class took a spelling test.
The diagram shows information about the scores.

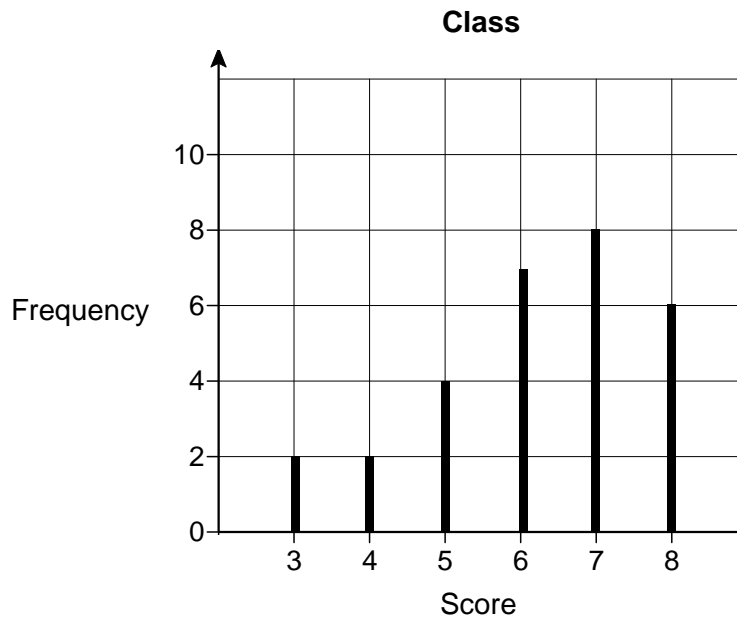

Lucy is one of the 29 students in the class.
Her score was the same as the **median** score for her class.

Work out her score.

[2 marks]

Answer _____

12

 $ABCH$ is a square. $HCFG$ is a rectangle. $CDEF$ is a square.

They are joined to make an L-shape.

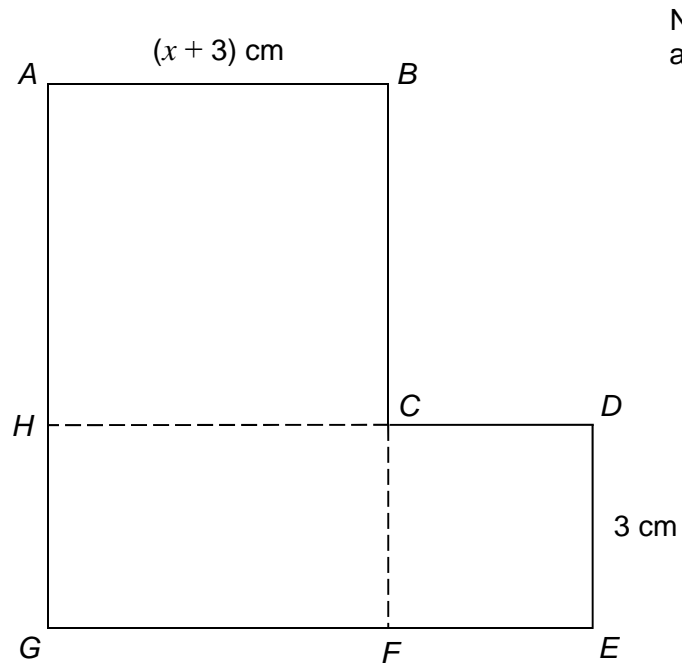
Not drawn
accuratelyShow that the total area of the L-shape, in cm^2 , is $x^2 + 9x + 27$ **[4 marks]**

13 Here are sketches of four triangles.

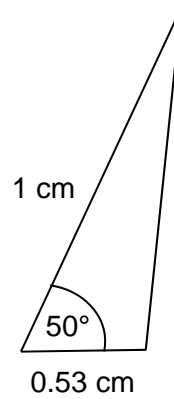
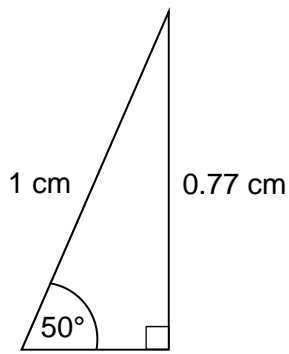

Not drawn accurately

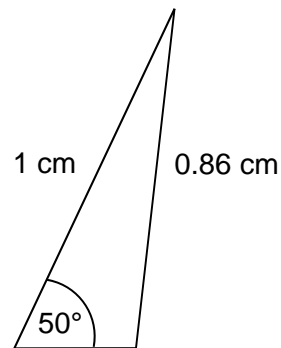
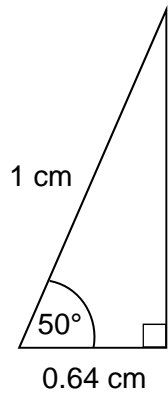

In each triangle

the longest side is **exactly** 1 cm

the other length is given to 2 decimal places.

13 (a) Circle the value of $\cos 50^\circ$ to 2 decimal places.

[1 mark]

0.77

0.53

0.64

0.86

- 13 (b)** Work out the value of x .
Give your answer to 1 decimal place.

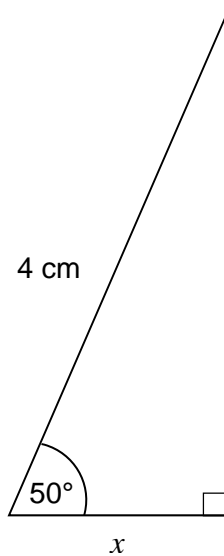

Not drawn
accurately

[2 marks]

Answer _____ cm

Turn over for the next question

- 14** A prime number between 300 and 450 is chosen at random.
The table shows the probability that the number lies in different ranges.

Prime number, n	Probability
$300 \leq n < 330$	0.16
$330 \leq n < 360$	0.24
$360 \leq n < 390$	x
$390 \leq n < 420$	0.16
$420 \leq n < 450$	0.24

- 14 (a)** Work out the value of x .

[2 marks]

Answer _____

- 14 (b)** Work out the probability that the prime number is greater than 390

[1 mark]

Answer _____

14 (c) There are four prime numbers between 300 and 330

How many prime numbers are there between 300 and 450?

[2 marks]

Answer _____

15 $a \times 10^4 + a \times 10^2 = 24\,240$ where a is a number.

Work out $a \times 10^4 - a \times 10^2$

Give your answer in standard form.

[2 marks]

Answer _____

- 16 AB , CD and YZ are straight lines.
All angles are in degrees.

Not drawn
accurately

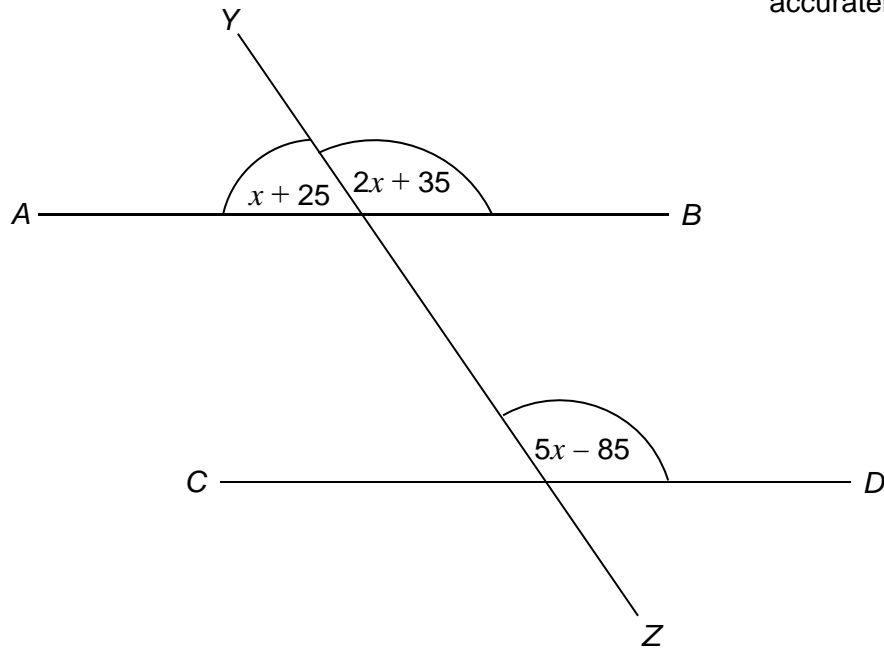

Show that AB is parallel to CD .

[4 marks]

17 To complete a task in 15 days a company needs
4 people each working for 8 hours per day.

The company decides to have
5 people each working for 6 hours per day.

Assume that each person works at the same rate.

17 (a) How many days will the task take to complete?
You **must** show your working.

[3 marks]

Answer _____

17 (b) Comment on how the assumption affects your answer to part (a).

[1 mark]

18 In this question all dimensions are in centimetres.

A solid has uniform cross section.

The cross section is a rectangle and a semicircle joined together.

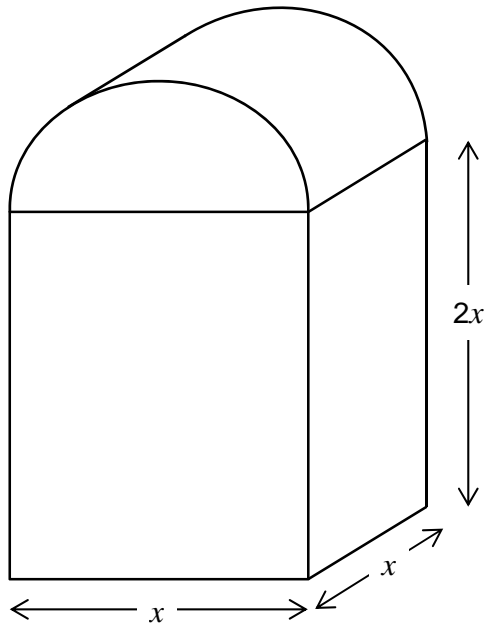

Work out an expression, in cm^3 , for the **total** volume of the solid.

Write your expression in the form $ax^3 + \frac{1}{b}\pi x^3$ where a and b are integers.

[4 marks]

Answer _____ cm^3

- 19** Show that $12 \cos 30^\circ - 2 \tan 60^\circ$ can be written in the form \sqrt{k} where k is an integer.

[3 marks]

Turn over for the next question

20 On Friday, Greg takes part in a long jump competition.
He has to jump at least 7.5 metres to qualify for the final on Saturday.

- He has up to three jumps to qualify.
- If he jumps at least 7.5 metres he does **not** jump again on Friday.

Each time Greg jumps, the probability he jumps at least 7.5 metres is 0.8
Assume each jump is independent.

20 (a) Complete the tree diagram.

[2 marks]

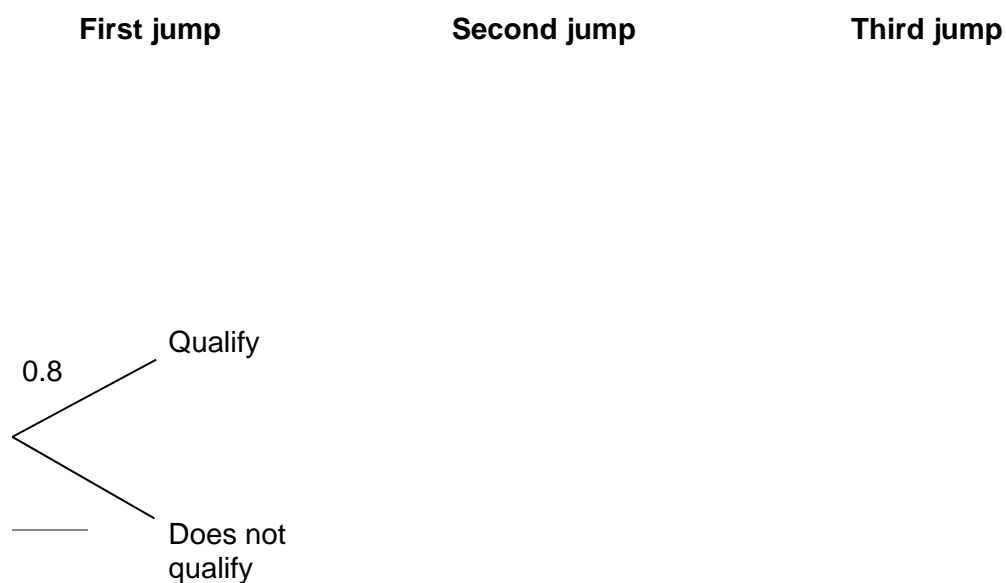

20 (b) Work out the probability that he does **not** need the third jump to qualify.

[2 marks]

Answer _____

21 A , B and C are points on a circle.

- BC bisects angle ABQ .
- PBQ is a tangent to the circle.

Not drawn
accurately

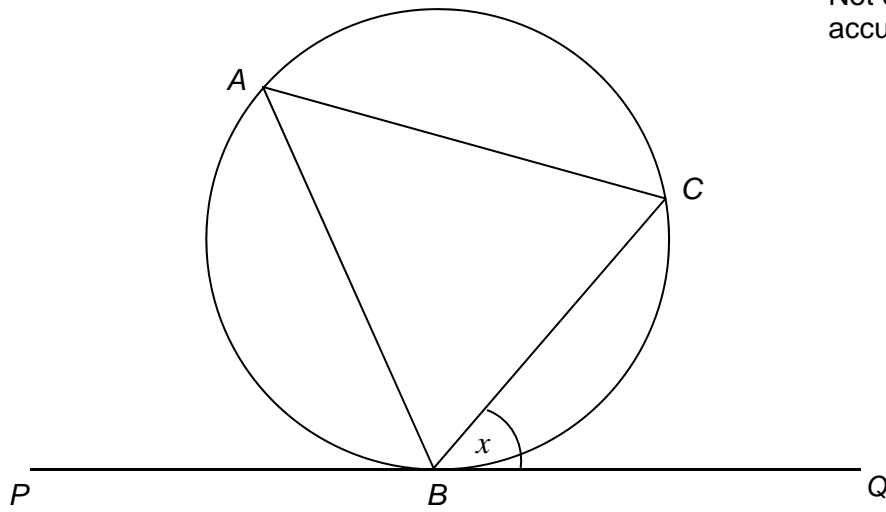

Angle $CBQ = x$

Prove that $AC = BC$

[3 marks]

Turn over for the next question

22 Steph is solving a problem.

Cube A has a surface area of 150 cm^2

Cube B has sides half the length of cube A

What is the volume of cube B?

To solve this problem, Steph decides to

- halve the surface area
- calculate the square root of the answer
- then divide by 6
- then cube this answer to work out the volume.

Evaluate Steph's method.

[2 marks]

23 Square $OABC$ is drawn on a centimetre grid.

O is $(0, 0)$ A is $(2, 0)$ B is $(2, 2)$ C is $(0, 2)$

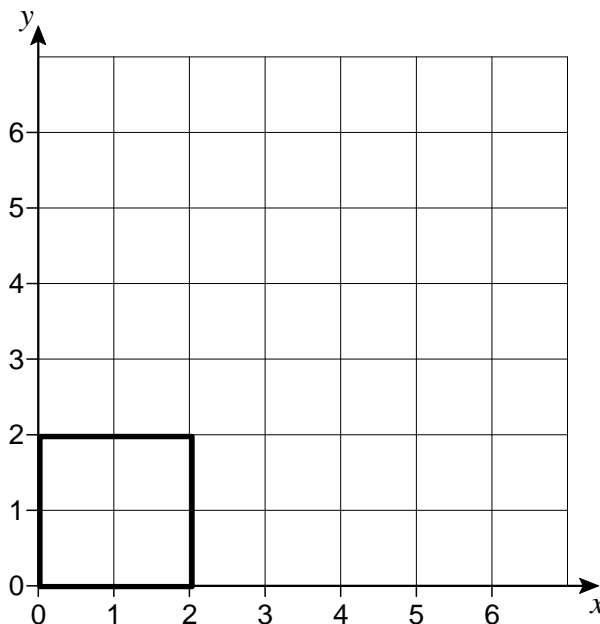

23 (a) $OABC$ is translated by the vector $\begin{pmatrix} 3 \\ 1 \end{pmatrix}$

Circle the number of invariant points on the perimeter of the square.

[1 mark]

0

1

2

4

23 (b) $OABC$ is enlarged, scale factor 2, centre $(0, 0)$

Circle the number of invariant points on the perimeter of the square.

[1 mark]

0

1

2

4

23 (c) $OABC$ is reflected in the line $y = x$

Circle the number of invariant points on the perimeter of the square.

[1 mark]

0

1

2

4

24 Here is the velocity-time graph of a car for 50 seconds.

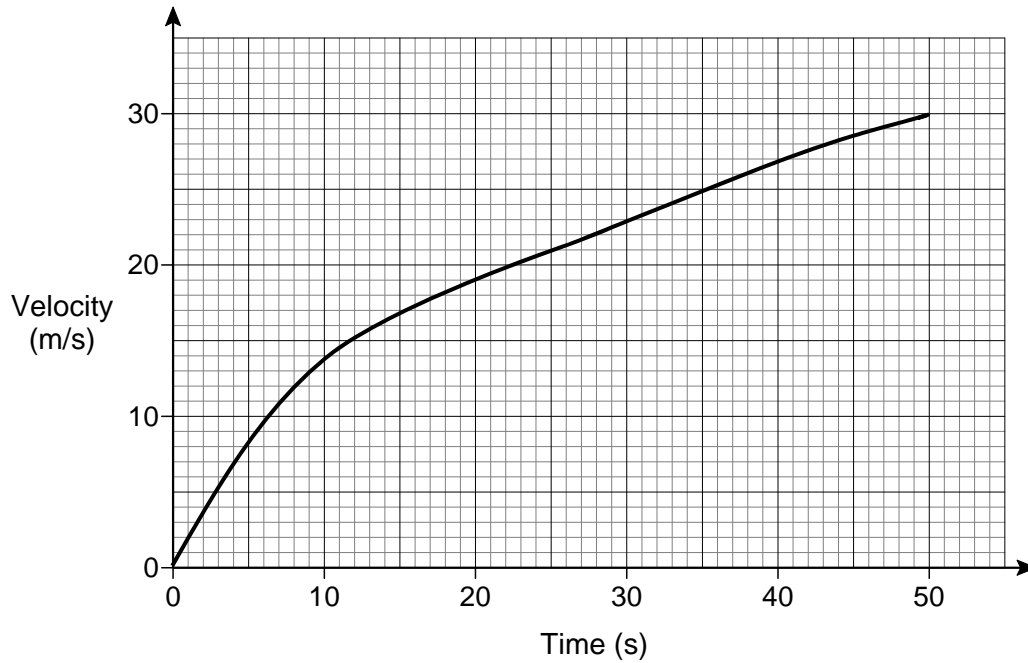

24 (a) Work out the average acceleration during the 50 seconds.
Give the units of your answer.

[2 marks]

Answer _____

24 (b) Estimate the time during the 50 seconds when
the instantaneous acceleration = the average acceleration

You **must** show your working on the graph.

[2 marks]

Answer _____ seconds

25

$$f(x) = 2x + c$$

$$g(x) = cx + 5$$

$$fg(x) = 6x + d$$

c and d are constants.

Work out the value of d .

[3 marks]

Answer _____

Turn over for the next question

26 Rationalise the denominator and simplify $\frac{10}{3\sqrt{5}}$

[2 marks]

Answer _____

27 Convert $0.1\dot{7}\dot{2}$ to a fraction in its lowest terms.

[3 marks]

Answer _____

28 The diagram shows the circle $x^2 + y^2 = 10$

P lies on the circle and has x -coordinate 1

The tangent at P intersects the x -axis at Q .

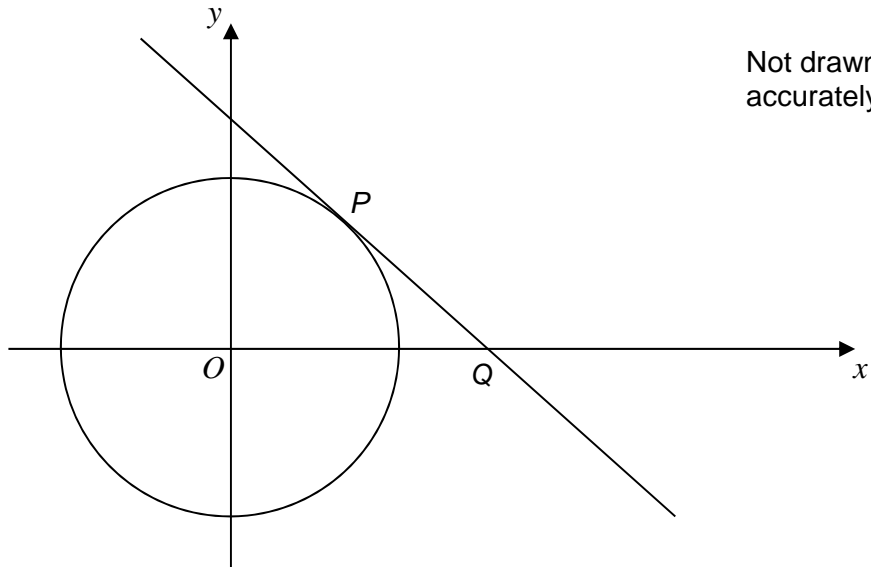

Not drawn
accurately

Work out the coordinates of Q .

[5 marks]

Answer (_____ , _____)

END OF QUESTIONS

There are no questions printed on this page

**DO NOT WRITE ON THIS PAGE
ANSWER IN THE SPACES PROVIDED**

GCSE Mathematics Specification (8300/2F)

F

Paper 2 Foundation tier

Date

Morning

1 hour 30 minutes

Materials

For this paper you must have:

- a calculator
- mathematical instruments.



Instructions

- Use black ink or black ball-point pen. Draw diagrams in pencil.
- Fill in the boxes at the bottom of this page.
- Answer **all** questions.
- You must answer the questions in the spaces provided. Do not write outside the box around each page or on blank pages.
- Do all rough work in this book.
- In all calculations, show clearly how you work out your answer.

Information

- The marks for questions are shown in brackets.
- The maximum mark for this paper is 80.
- You may ask for more answer paper, graph paper and tracing paper. These must be tagged securely to this answer book.

Please write clearly, in block capitals, to allow character computer recognition.

Centre number

Candidate number

Surname

Forename(s)

Candidate signature _____

Answer **all** questions in the spaces provided.

1 Which of these numbers is **one more** than a multiple of 5?

Circle your answer.

[1 mark]

15

19

26

30

2 Which of these numbers has **exactly three** factors?

Circle your answer.

[1 mark]

3

4

5

6

3 Which of these numbers is 6 **less** than -1.4 ?

Circle your answer.

[1 mark]

-8.4

-7.4

-2.0

4.6

- 4 Which shape is congruent to shape X?
Circle the correct letter.

[1 mark]

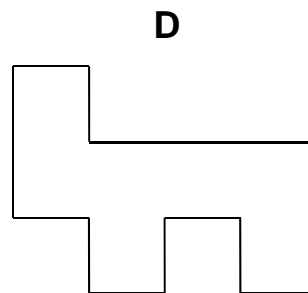
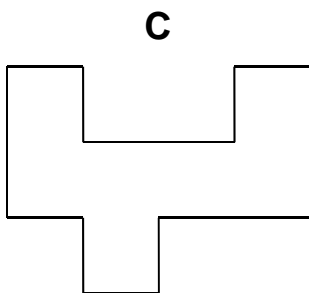
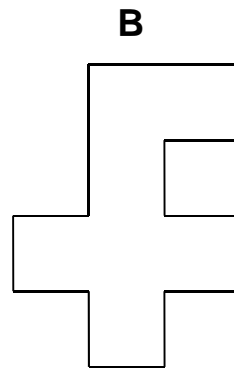
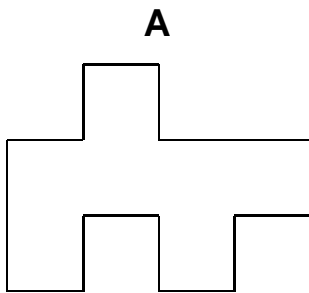
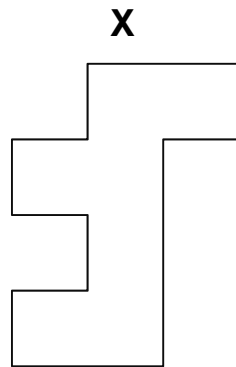

- 5 The map shows the positions of two ships, A and B.

Scale: 1 cm represents 2.5 km

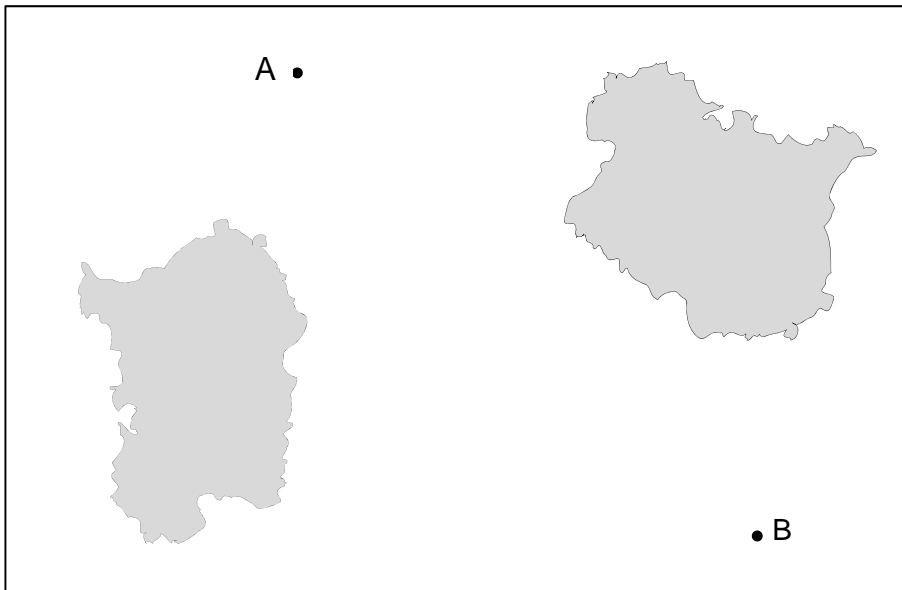

Work out the actual distance between the ships.

[2 marks]

Answer _____ km

6 A gym has 275 members.

40% are bronze members.

28% are silver members.

The rest are gold members.

Work out the number of gold members.

[3 marks]

Answer _____

Turn over for the next question

7 (a) Alan is looking at number machine problems.

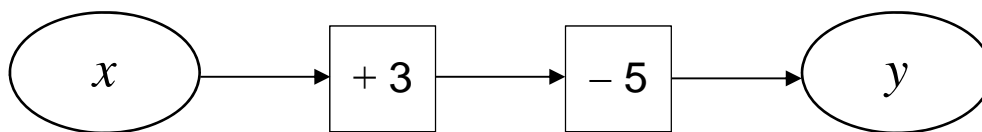

He says,

“If I know y I can work out x .
I subtract 3 then I add 5.”

Does this method work?

Give a reason for your answer.

[1 mark]

7 (b)

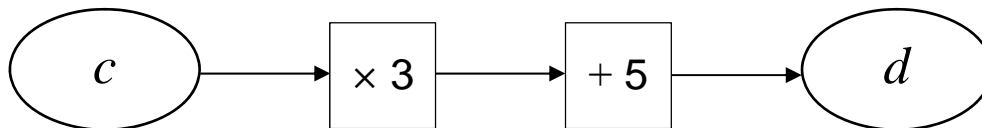

He says,

“If I know d I can work out c .
I divide by 3, then subtract 5.”

Does this method work?

Give a reason for your answer.

[1 mark]

8 (a) Solve $5w - 11 = 24$

[2 marks]

$w =$ _____

8 (b) Write an expression for the total cost, in pounds, of

x jumpers at £15 each
and
 y shirts at £12 each.

[1 mark]

Answer _____

8 (c) Simplify $x + x + y \times y$

[1 mark]

Answer _____

- 9 Lucy says,
"3 is odd and 2 is even,
so when you add a multiple of 3 to a multiple of 2 the answer is always odd."

Is she correct?

Write down a calculation to support your answer.

[1 mark]

- 10 Tom earns £9.20 per hour.

He works for

24 hours each week

48 weeks each year.

He pays tax if he earns more than £10 000 per year.

Does Tom pay tax?

You **must** show your working.

[2 marks]

- 11 Three boxes contain counters.

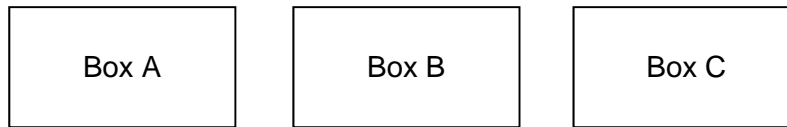

There are 62 counters in total.

The total number of counters in box A and box B is 34

The difference between the number of counters in box A and box C is 9

Work out the number of counters in each box.

[3 marks]

Box A _____ Box B _____ Box C _____

Turn over for the next question

- 12** The pie chart shows information about the sales of 800 tickets.
There were twice as many adult ticket sales as senior ticket sales.

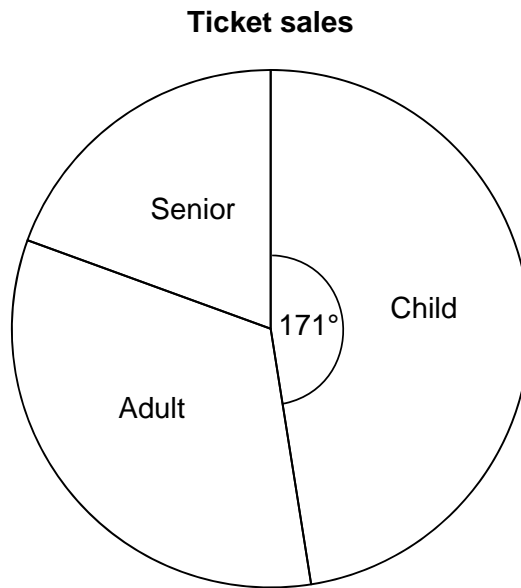

- 12 (a)** Show that there were 140 senior ticket sales.

[3 marks]

12 (b) Draw a bar chart on the grid to represent the child, adult and senior ticket sales.

[4 marks]

Ticket sales

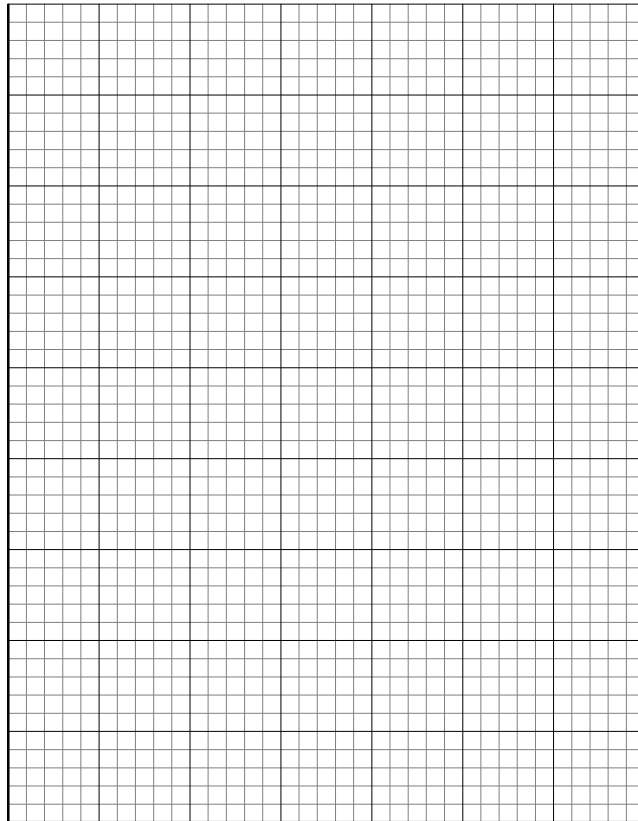

- 13** Alice makes cards.
Each card uses 42 cm of ribbon.
She has 1000 cm of ribbon.

13 (a) Work out the **maximum** number of cards she can make.

[2 marks]

Answer _____

13 (b) How much ribbon will be left over?

[1 mark]

Answer _____ cm

- 14** Luke saves 10p coins and 20p coins.
He has
 three times as many 10p coins as 20p coins
 a total of £17

How many 10p coins does he have?

[3 marks]

Answer _____

Turn over for the next question

- 15** A company has bikes for hire.
The cost, £ C , to hire a bike for n days is given by the formula

$$C = 12 + \frac{27}{4}(n - 1)$$

- 15 (a)** Write down the cost to hire a bike for 1 day.

[1 mark]

Answer £ _____

- 15 (b)**

Special offer

Hire a bike for £9 per day

Is it cheaper to hire a bike for 7 days using the special offer?

You **must** show your working.

[2 marks]

- 15 (c) The graph shows the cost to hire a bike for one to five days at a different company.

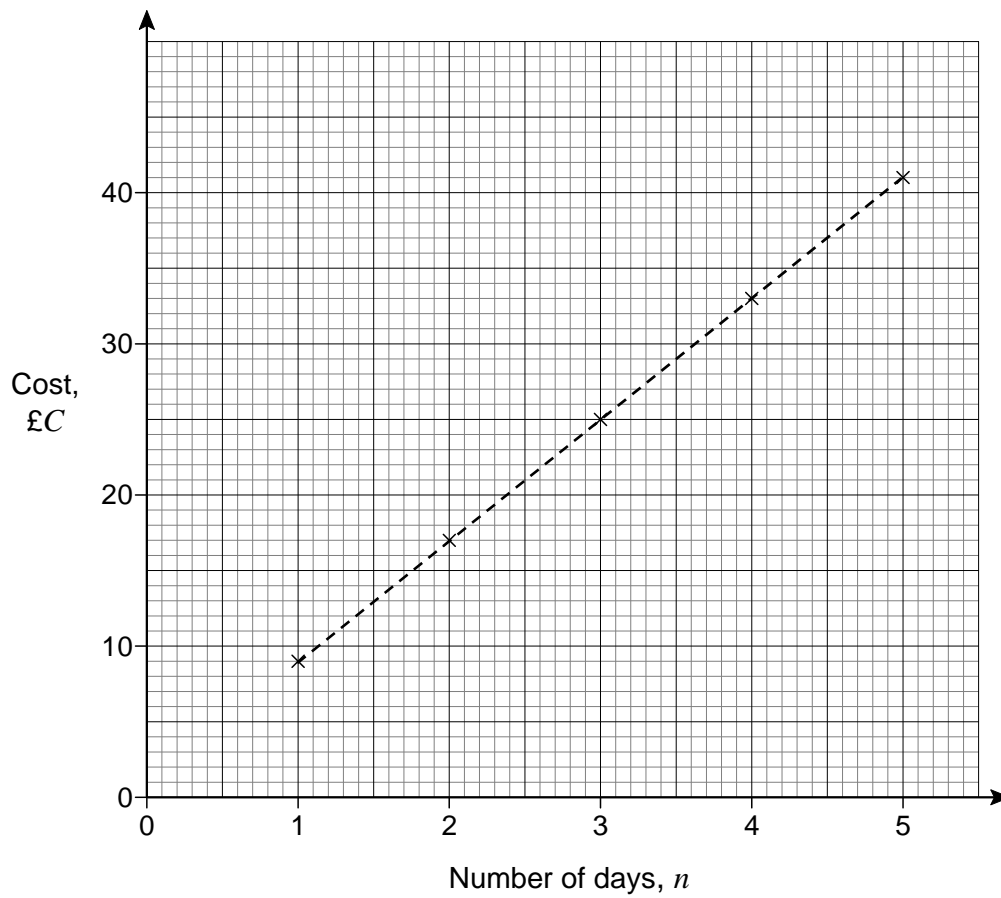

The cost, $\text{£}C$, to hire a bike for n days using this company is given by the formula

$$C = a + b(n - 1)$$

Work out the values of a and b .

[3 marks]

$$a = \underline{\hspace{2cm}} \qquad b = \underline{\hspace{2cm}}$$

16 A company's logo

- is a pentagon
- has exactly one line of symmetry
- has sides with whole number lengths
- has a perimeter of 15 cm

Draw a sketch of a possible logo.

Label each side with its length.

[2 marks]

17 Mr Jones works for five days each week.

If he uses his car to travel to work,
each day he drive a total distance of 24.2 miles
his car travels 32.3 miles per gallon of petrol
petrol costs £1.27 per litre.

If he uses the bus to travel to work, he can buy a weekly ticket for £19.50

Use 1 gallon = 4.5 litres

Is it cheaper if he uses his car or the bus to travel to work?

You **must** show your working.

[5 marks]

Answer _____

18 Here are two number machines, **A** and **B**.

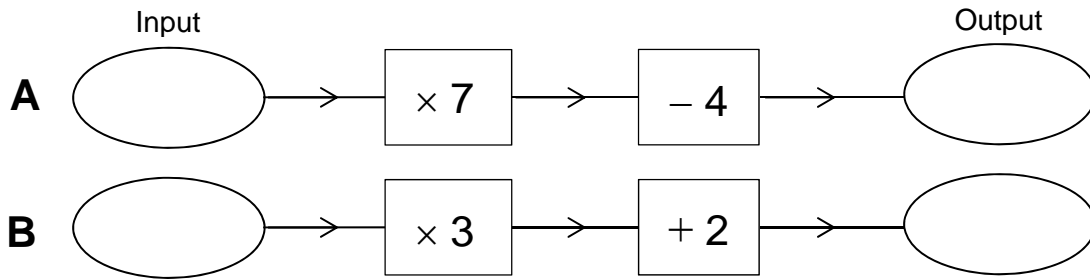

Both machines have the same input.

Work out the input that makes

the output of **A** three times the output of **B**.

[4 marks]

Answer _____

- 19** Josef runs 400 metres in 1 minute.
He assumes he can run any distance at the same rate.
He says,

“I would run 10 000 metres in 25 minutes.”

Tick a box to show whether his time to run 10 000 metres is likely to be accurate.

No, the time will be longer

Yes, the time will be 25 minutes

No, the time will be shorter

Give working and a reason to support your answer.

[2 marks]

- 20** Which sequence is a geometric progression?
Circle your answer.

[1 mark]

1 2 3 4

1 2 4 7

1 2 4 8

1 2 3 5

- 21 This pyramid has a square base.

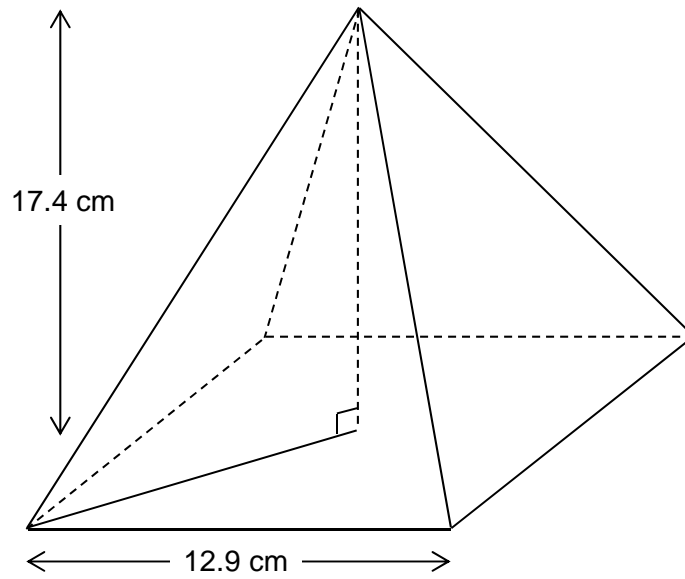

Volume of a pyramid = $\frac{1}{3}$ × area of base × perpendicular height

Work out the volume of the pyramid.

[3 marks]

Answer _____ cm³

22 $\xi = \{1, 2, 3, 4, 5, 6, 7, 8, 9, 10, 11, 12\}$

S = square numbers

E = even numbers

22 (a) Complete the Venn diagram.

[3 marks]

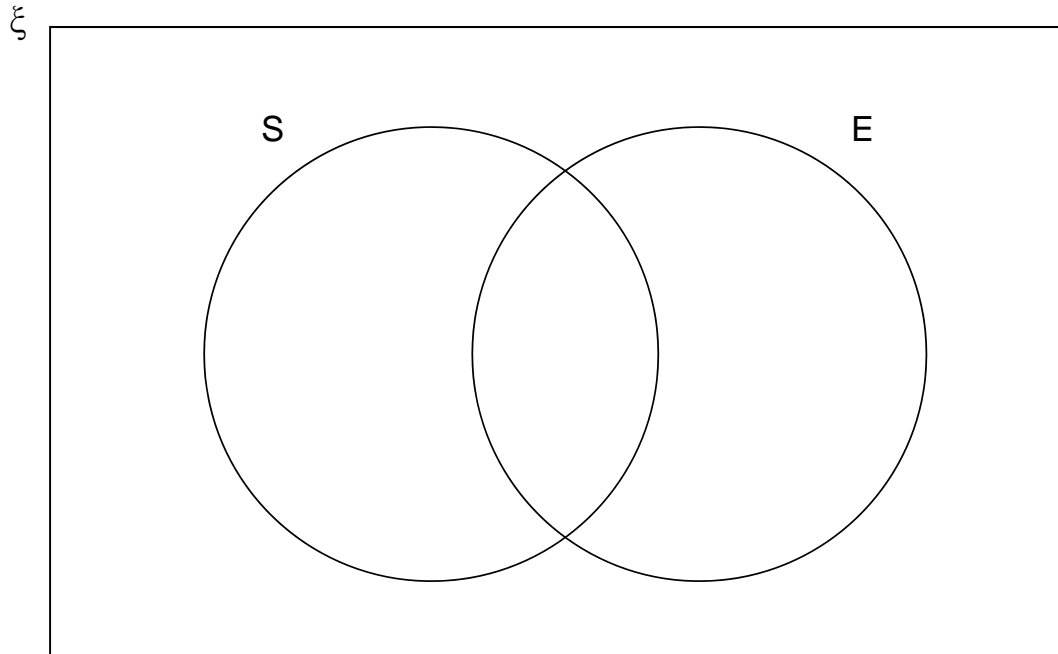

22 (b) One of the numbers is chosen at random.

Write down $P(S \cap E)$

[1 mark]

Answer _____

- 23** A coin is rolled onto a grid of squares.
It lands randomly on the grid.
To win, the coin must land completely within one of the squares.

Meera and John each roll the coin a number of times and record their results.

	Number of wins	Number of losses
Meera	6	44
John	28	72

- 23 (a)** Work out **two** different estimates for the probability of winning.

[2 marks]

Answer _____ and _____

- 23 (b)** Which of your estimates is the better estimate for the probability of winning?
Give a reason for your answer.

[1 mark]

Answer _____

Reason _____

24 In a sale, the original price of a bag was reduced by $\frac{1}{5}$

The sale price of the bag is £29.40

Work out the original price.

[3 marks]

Answer £ _____

25 Which of these is **not** used to prove that triangles are congruent?

Circle your answer.

[1 mark]

SSS

SAS

AAA

RHS

Turn over for the next question

26

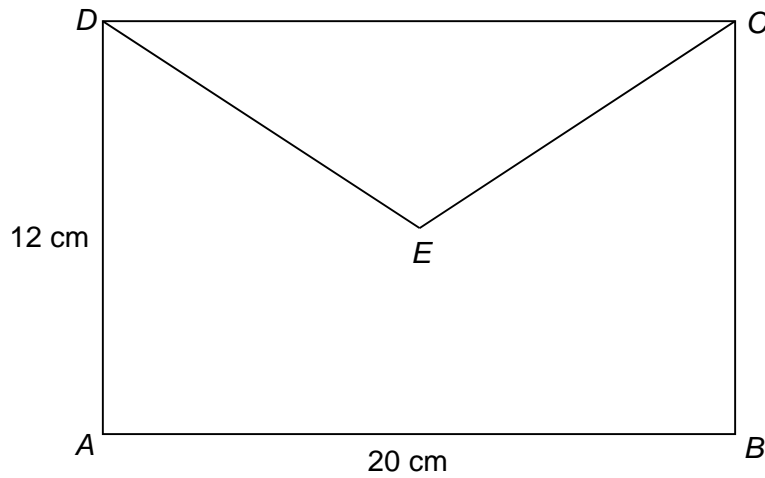
 E is the centre of rectangle $ABCD$.Not drawn
accuratelyWork out the length DE .**[3 marks]**

Answer _____ cm

27

Circle the equation of a line that is parallel to $y = 5x - 2$ **[1 mark]**

$y = 2x - 5$

$y = 5x + 2$

$y = 3x - 2$

$y = -\frac{1}{5}x - 2$

28 At a school

number of boys : number of girls = 9 : 7

There are 116 **more** boys than girls.

Work out the total number of students at the school.

[3 marks]

Answer _____

29 Circle the equation with roots 4 and -8

[1 mark]

$$4x(x - 8) = 0$$

$$(x - 4)(x + 8) = 0$$

$$x^2 - 32 = 0$$

$$(x + 4)(x - 8) = 0$$

30 A pattern is made from two **similar** trapeziums.

Not drawn accurately

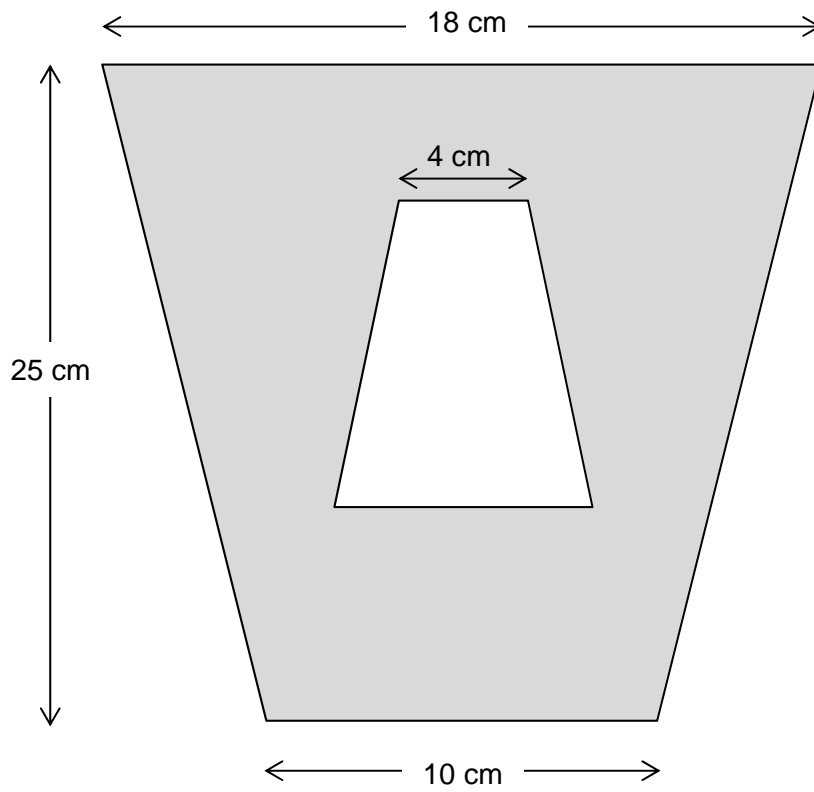

Show that the shaded area is 294 cm^2

[4 marks]

END OF QUESTIONS

GCSE Mathematics Specification (8300/2H)

H

Paper 2 Higher tier

Date

Morning

1 hour 30 minutes

Materials

For this paper you must have:

- a calculator
- mathematical instruments.



Instructions

- Use black ink or black ball-point pen. Draw diagrams in pencil.
- Fill in the boxes at the bottom of this page.
- Answer **all** questions.
- You must answer the questions in the spaces provided. Do not write outside the box around each page or on blank pages.
- Do all rough work in this book.
- In all calculations, show clearly how you work out your answer.

Information

- The marks for questions are shown in brackets.
- The maximum mark for this paper is 80.
- You may ask for more answer paper, graph paper and tracing paper. These must be tagged securely to this answer book.

Please write clearly, in block capitals, to allow character computer recognition.

Centre number

Candidate number

Surname

Forename(s)

Candidate signature _____

Answer **all** questions in the spaces provided.

1 Which sequence is a geometric progression?

Circle your answer.

[1 mark]

1 2 3 4

1 2 4 7

1 2 4 8

1 2 3 5

2 Which of these is **not** used to prove that triangles are congruent?

Circle your answer.

[1 mark]

SSS

SAS

AAA

RHS

3 Circle the expression that is equivalent to $2a + 5a \times 4a - a$

[1 mark]

$$a + 20a^2$$

$$21a^2$$

$$28a^2 - a$$

$$2a + 15a^2$$

4 Circle the equation of a line that is parallel to $y = 5x - 2$

[1 mark]

$$y = 2x - 5$$

$$y = 5x + 2$$

$$y = 3x - 2$$

$$y = -\frac{1}{5}x - 2$$

5 In a sale, the original price of a bag was reduced by $\frac{1}{5}$

The sale price of the bag is £29.40

Work out the original price.

[3 marks]

Answer £ _____

Turn over for the next question

6 $\xi = \{1, 2, 3, 4, 5, 6, 7, 8, 9, 10, 11, 12\}$

S = square numbers

E = even numbers

6 (a) Complete the Venn diagram.

[3 marks]

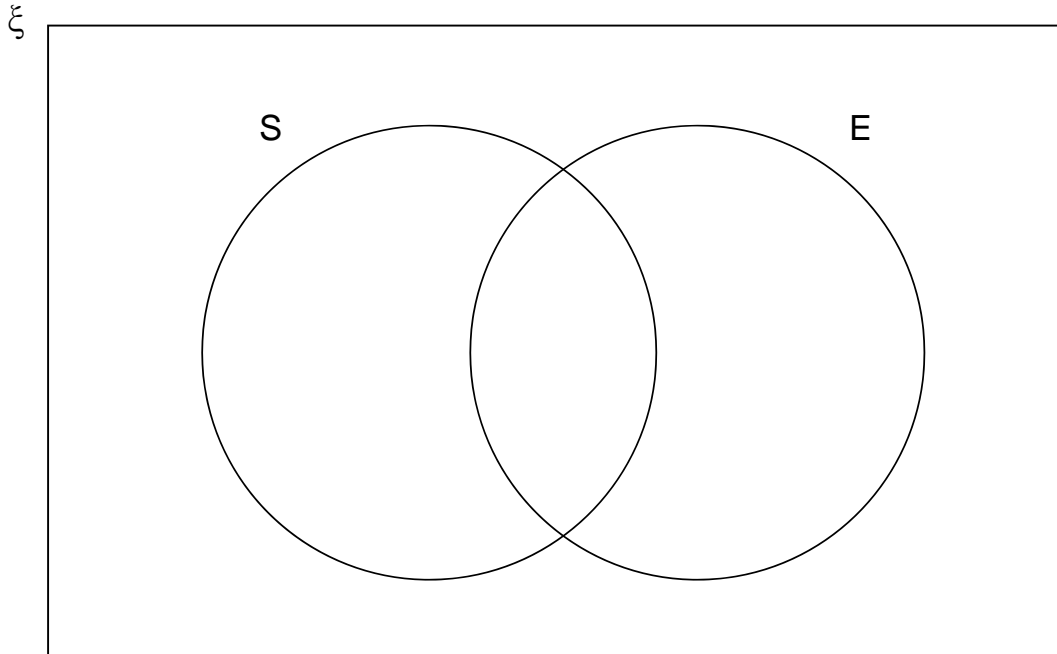

6 (b) One of the numbers is chosen at random.

Write down $P(S \cap E)$

[1 mark]

Answer _____

- 7** A coin is rolled onto a grid of squares.
It lands randomly on the grid.
To win, the coin must land completely within one of the squares.

Meera and John each roll the coin a number of times and record their results.

	Number of wins	Number of losses
Meera	6	44
John	28	72

- 7 (a)** Work out **two** different estimates for the probability of winning.

[2 marks]

Answer _____ and _____

- 7 (b)** Which of your estimates is the better estimate for the probability of winning?
Give a reason for your answer.

[1 mark]

Answer _____

Reason _____

- 8 Here is the graph of $4x - 3y = 12$ for values of x from 0 to 4

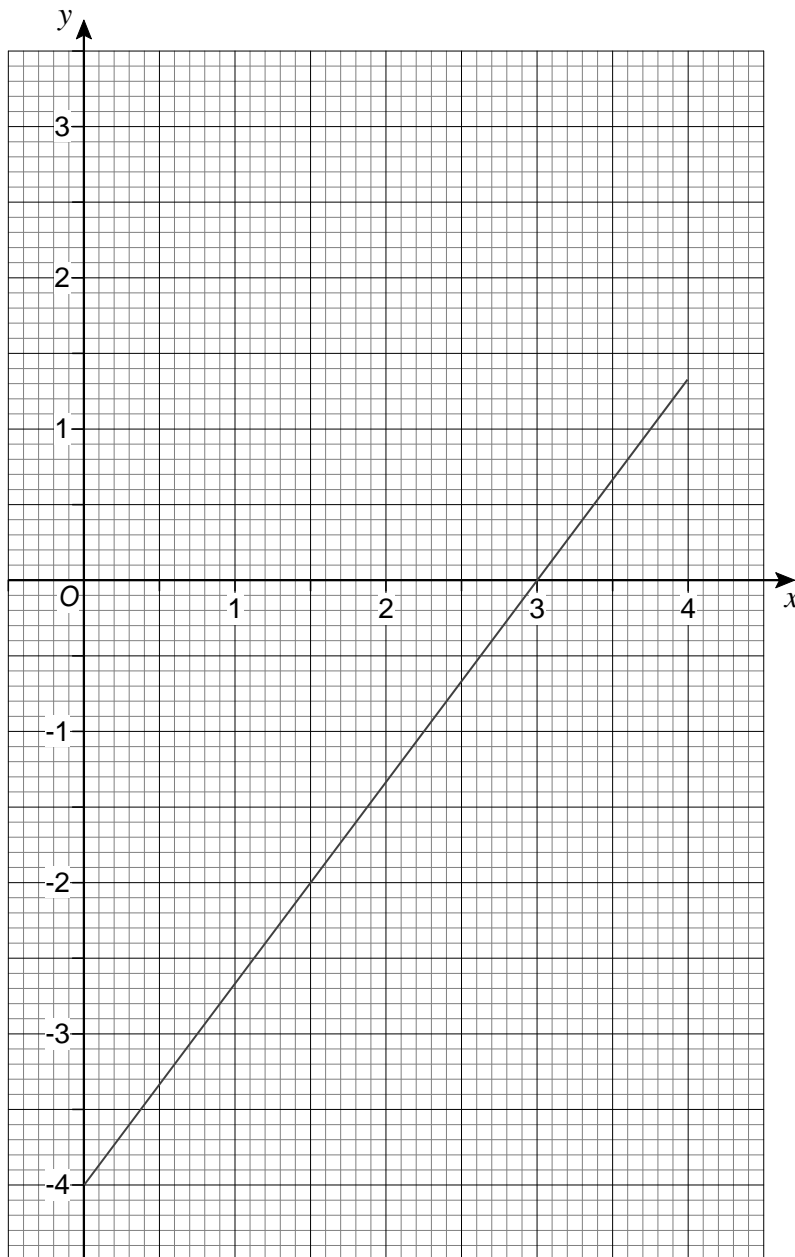

By drawing a second graph on the grid,
work out an approximate solution to the simultaneous equations

$$4x - 3y = 12 \quad \text{and} \quad 3x + 2y = 6$$

[3 marks]

Answer _____

9 Written as the product of its prime factors

$$672 = 2^5 \times 3 \times 7$$

9 (a) Write 252 as the product of its prime factors.

[2 marks]

Answer _____

9 (b) Work out the value of the highest common factor of 672 and 252

[1 mark]

Answer _____

Turn over for the next question

10 At a school

number of boys : number of girls = 9 : 7

There are 116 **more** boys than girls.

Work out the total number of students at the school.

[3 marks]

Answer _____

11 Circle the equation with roots 4 and -8

[1 mark]

$$4x(x - 8) = 0$$

$$(x - 4)(x + 8) = 0$$

$$x^2 - 32 = 0$$

$$(x + 4)(x - 8) = 0$$

12 $R = \frac{x^2}{y}$

$$x = 3.6 \times 10^5$$

$$y = 7.5 \times 10^4$$

Work out the value of R .

Give your answer in standard form to an appropriate degree of accuracy.

[3 marks]

Answer _____

13 Two spheres have radii in the ratio 5 : 3

Circle the ratio of their volumes.

[1 mark]

5 : 3

15 : 9

25 : 9

125 : 27

Turn over for the next question

14 (a) A pattern is made from two **similar** trapeziums.

Not drawn accurately

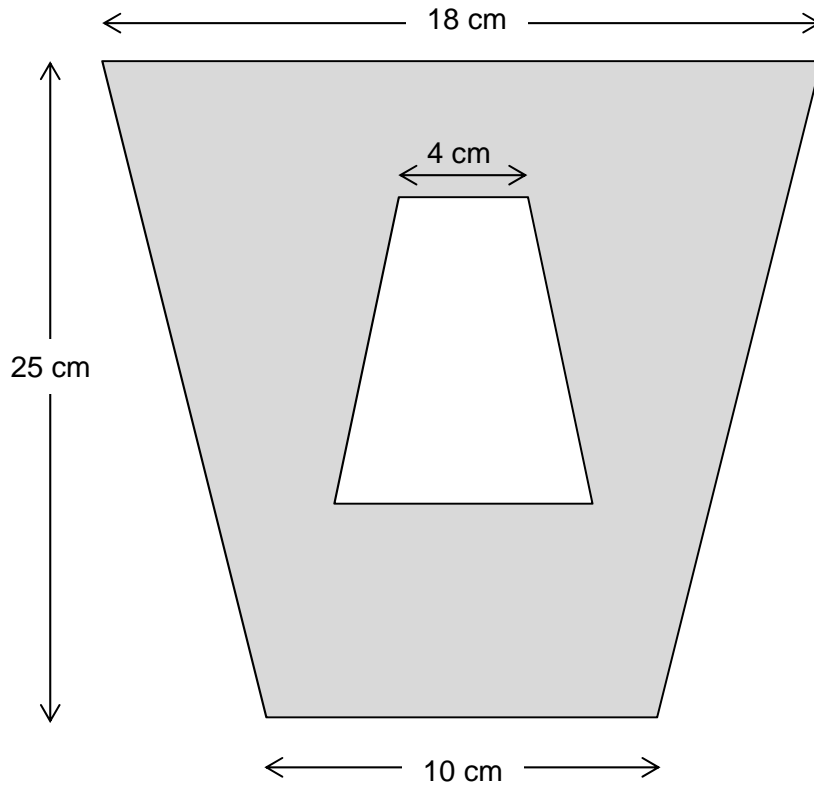

Show that the shaded area is 294 cm^2

[4 marks]

14 (b) The pattern has one line of symmetry.

Not drawn accurately

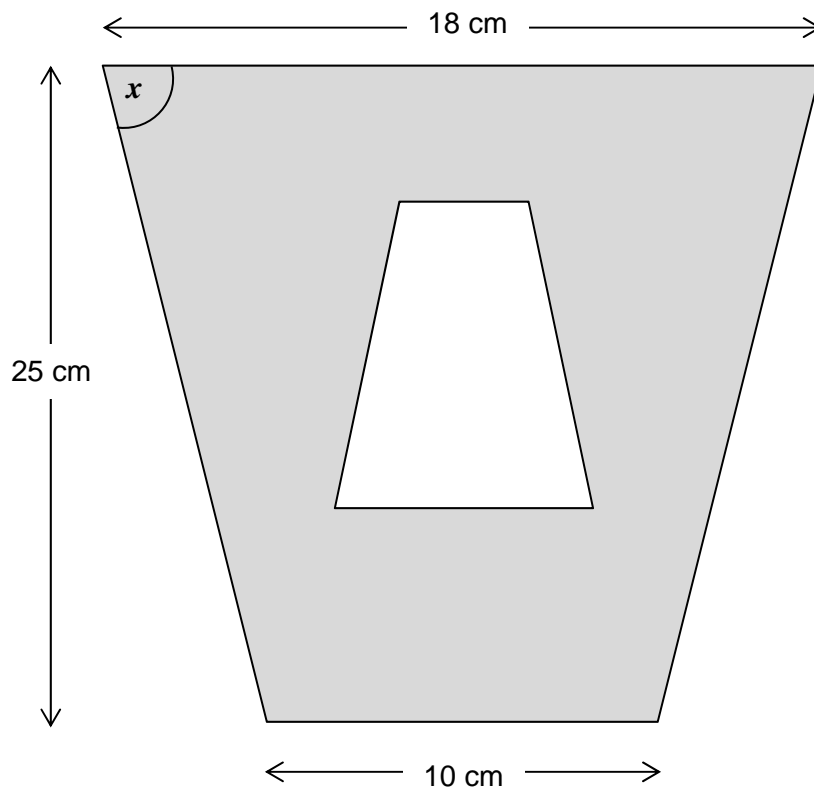

Work out the size of angle x .

[3 marks]

Answer _____ degrees

15 Ann picks a 4-digit number.

The first digit is **not** zero.

The 4-digit number is a multiple of 5

How many different 4-digit numbers could she pick?

[3 marks]

Answer _____

16 c is a positive integer.

Prove that $\frac{6c^3 + 30c}{3c^2 + 15}$ is an even number.

[3 marks]

18 In the formula $T = (n - 6)^2 + 1$ n is a positive integer.

18 (a) Kim says,

“The value of T is always greater than 1
because $(n - 6)^2$ is always greater than 0”

Comment on her statement.

[1 mark]

18 (b) What is the only value of T that is a square number?

[1 mark]

Answer _____

19 $f(x) = 3x$

Circle the expression for $f^{-1}(x)$ **[1 mark]**

$-3x$

$\frac{3}{x}$

$\frac{1}{3x}$

$\frac{x}{3}$

20 y is directly proportional to \sqrt{x}

x	36	a
y	2	5

Work out the value of a .**[4 marks]**

Answer _____

- 21 A company makes boxes of cereal.
A box usually contains 450 grams of cereal.
Here are two options for a special offer.

Option A

20% more cereal
Price remains the same

Option B

Usual amount of cereal
15% off the price

Which option is the better value for the customer?
You **must** show your working.

[3 marks]

Answer _____

22

The histogram shows the ages, in years, of members of a chess club.

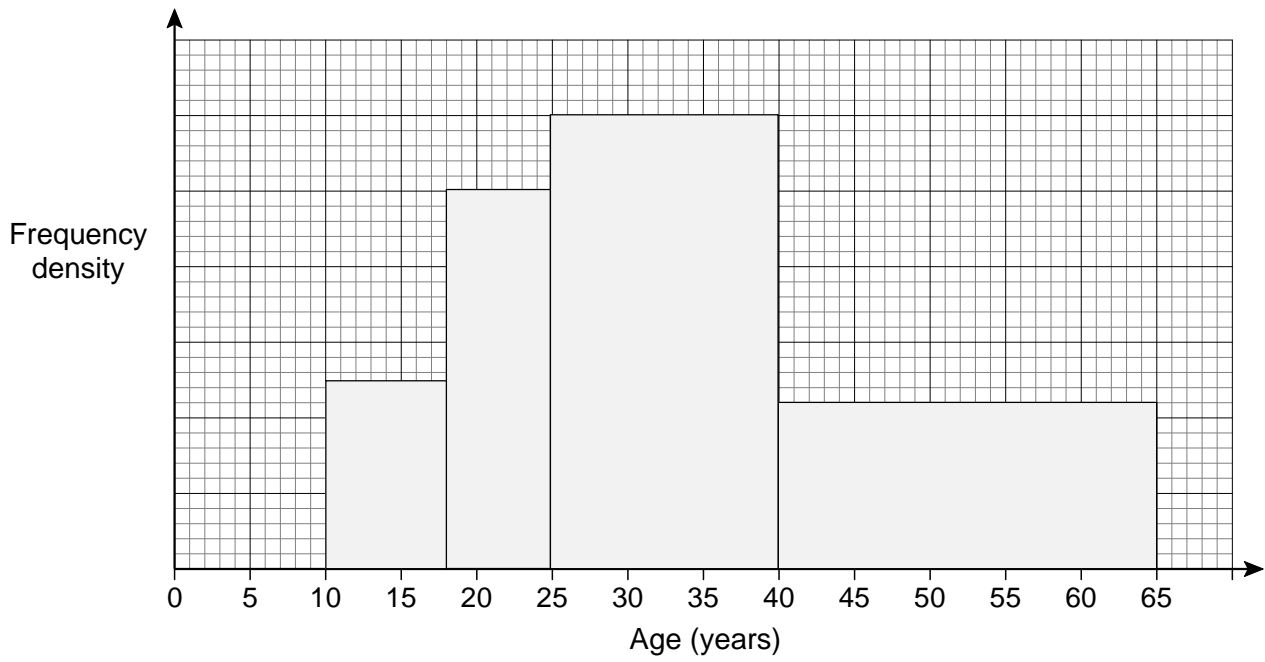

There are 22 members with ages in the range $40 \leq \text{age} < 65$

Work out the number of members with ages in the range $25 \leq \text{age} < 40$

[4 marks]

Answer _____

23

A bowl is a hemisphere with radius 6 cm

Water fills two-fifths of the volume of the bowl.

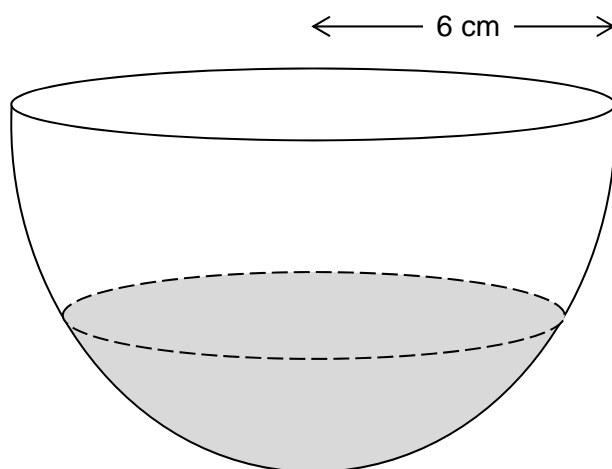

The water is poured into a hollow cone.

The depth of the water in the cone is 12 cm

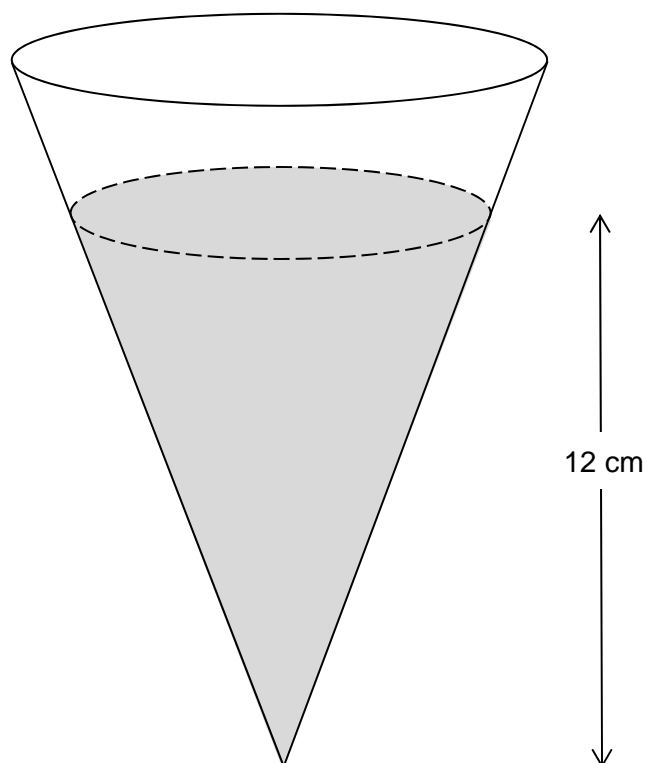

- 24** A Big Wheel is modelled as a circle with centre O and radius 15 metres.
The wheel turns in an anticlockwise direction.
The lowest point on the wheel is always 2 metres above horizontal ground.

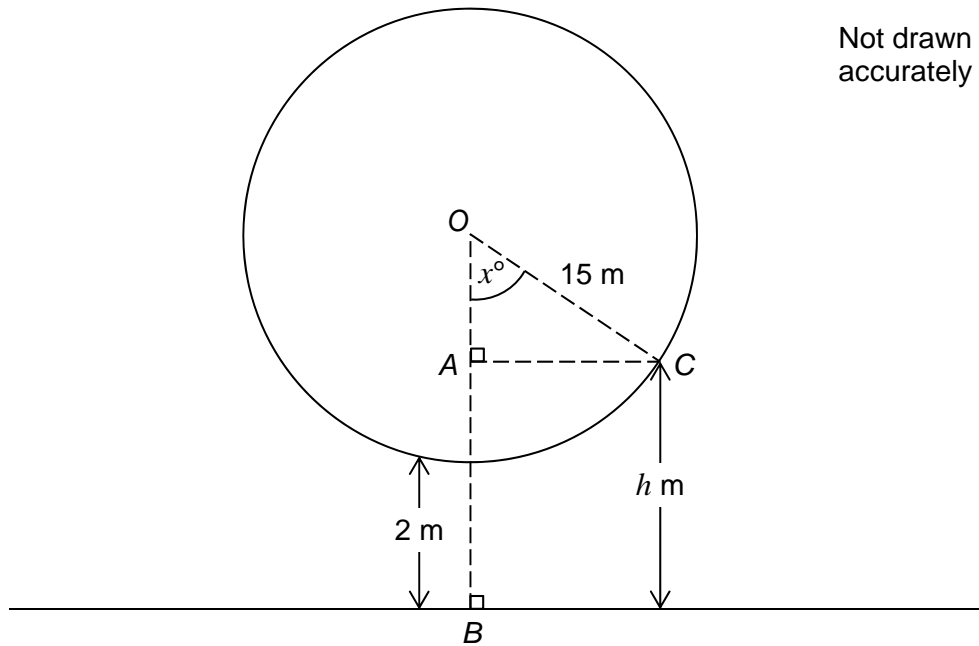

- 24 (a)** C is a point on the wheel, h metres above horizontal ground.
Angle $COB = x^\circ$

Show that $h = 17 - 15 \cos x^\circ$

[2 marks]

- 24 (b)** D is a point on the wheel.
Angle $DOB = 120^\circ$

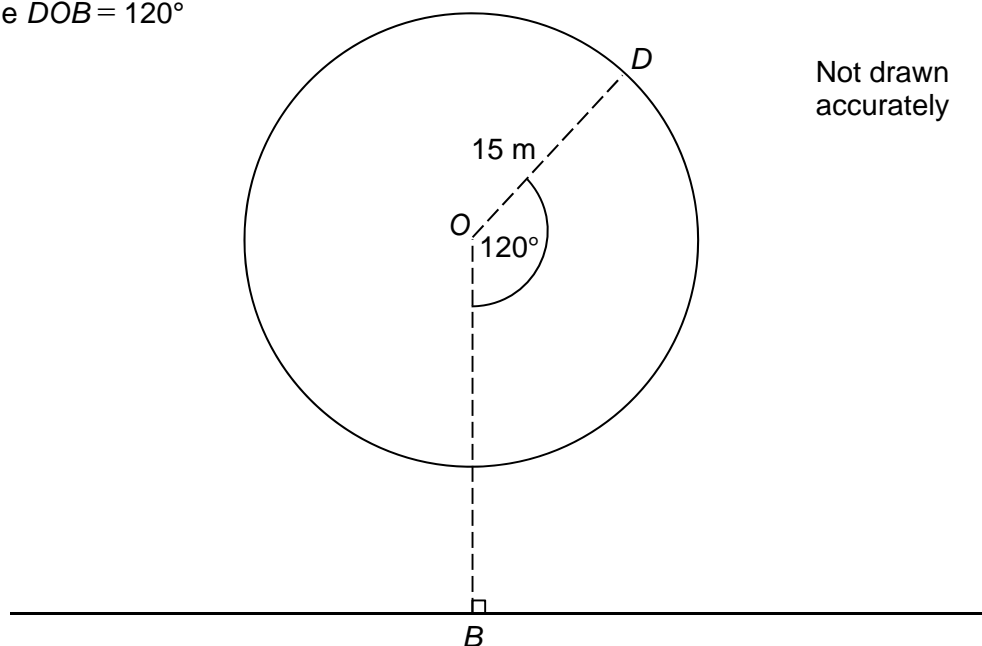

Work out the height of D above horizontal ground.

[2 marks]

Answer _____ metres

- 24 (c)** Here is a sketch of the graph $h = 17 - 15 \cos x^\circ$ for one **complete** turn of the wheel.
 P is the highest point on the graph.

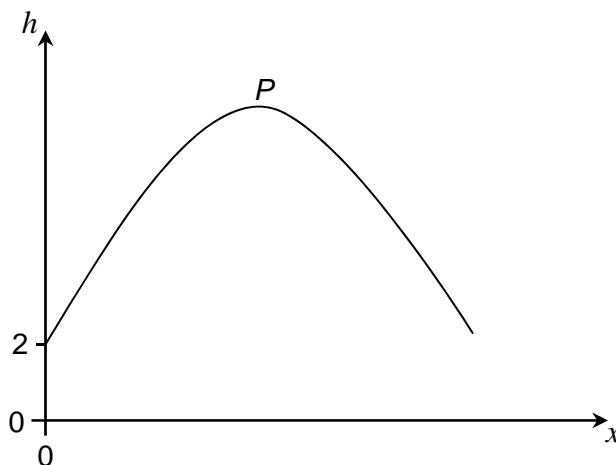

Work out the coordinates of P .

[2 marks]

Answer (_____ , _____)

25 $2x^2 - 6x + 5$ can be written in the form $a(x - b)^2 + c$
where a , b and c are positive numbers.

25 (a) Work out the values of a , b and c .

[3 marks]

$$a = \underline{\hspace{4cm}}$$

$$b = \underline{\hspace{4cm}}$$

$$c = \underline{\hspace{4cm}}$$

- 26** Two boxes are made with card.
The boxes are similar cuboids.
The smaller box has height 32 cm

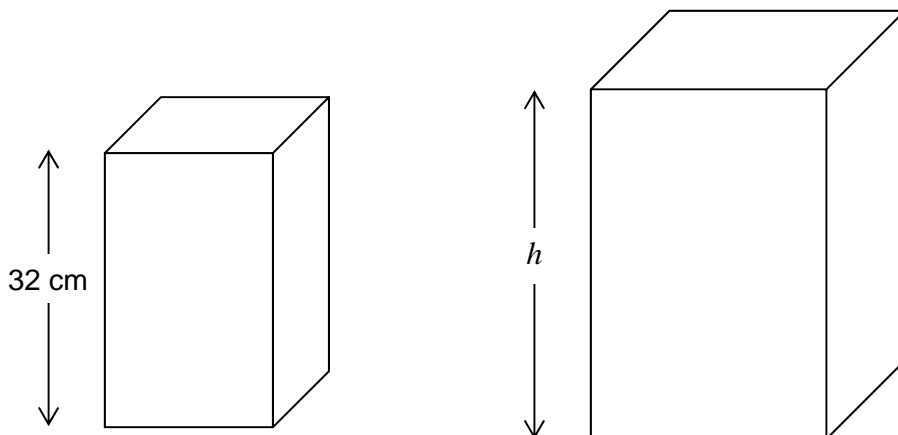

It takes 44% more card to make the larger box.

Work out the height, h , of the larger box.

[4 marks]

Answer _____ cm

END OF QUESTIONS

Answer **all** questions in the spaces provided.

1 Here are seven numbers.

13 6 12 7 6 4 8

1 (a) Work out the range of the seven numbers.

Circle your answer.

[1 mark]

5 6 7 8 9

1 (b) What is the mode of the seven numbers?

Circle your answer.

[1 mark]

5 6 7 8 9

- 2 Which shape has **two** lines of symmetry **and** its diagonals intersecting at 90° ?
Circle the correct letter.

[1 mark]

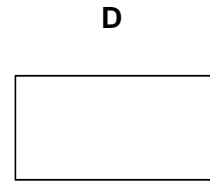
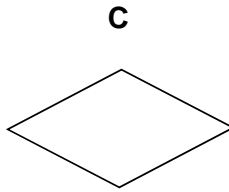
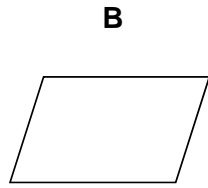
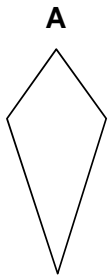

- 3 Which of these is a cube number?
Circle your answer.

[1 mark]

3

9

27

100

Turn over for the next question

4 Liz buys a car for £7500

She pays a deposit of £1875

She pays the rest in 36 equal monthly payments.

Work out the amount of each monthly payment.

[3 marks]

Answer £ _____

5 120 men and 80 women were asked if they drive to work.

Altogether $\frac{1}{4}$ of the people said yes.

$\frac{1}{3}$ of the men said yes.

What fraction of the women said yes?

[4 marks]

Answer _____

6 Boxes A, B, C and D contain balls with numbers on them.

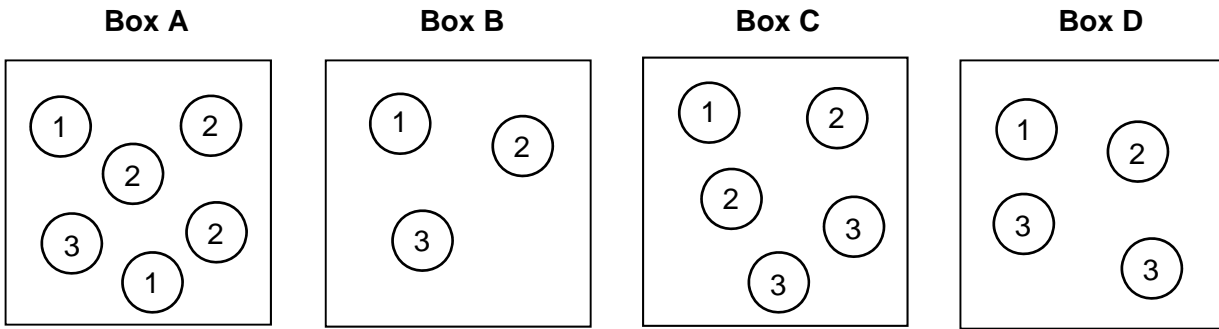

A ball is picked at random from each box.

6 (a) Which box gives the **greatest** chance of picking a 3?
You **must** show your working.

[2 marks]

Box _____

6 (b) Which two boxes give the **same** chance of picking a 1?

[1 mark]

Box _____ and Box _____

7 Zayn records his weekly sales.

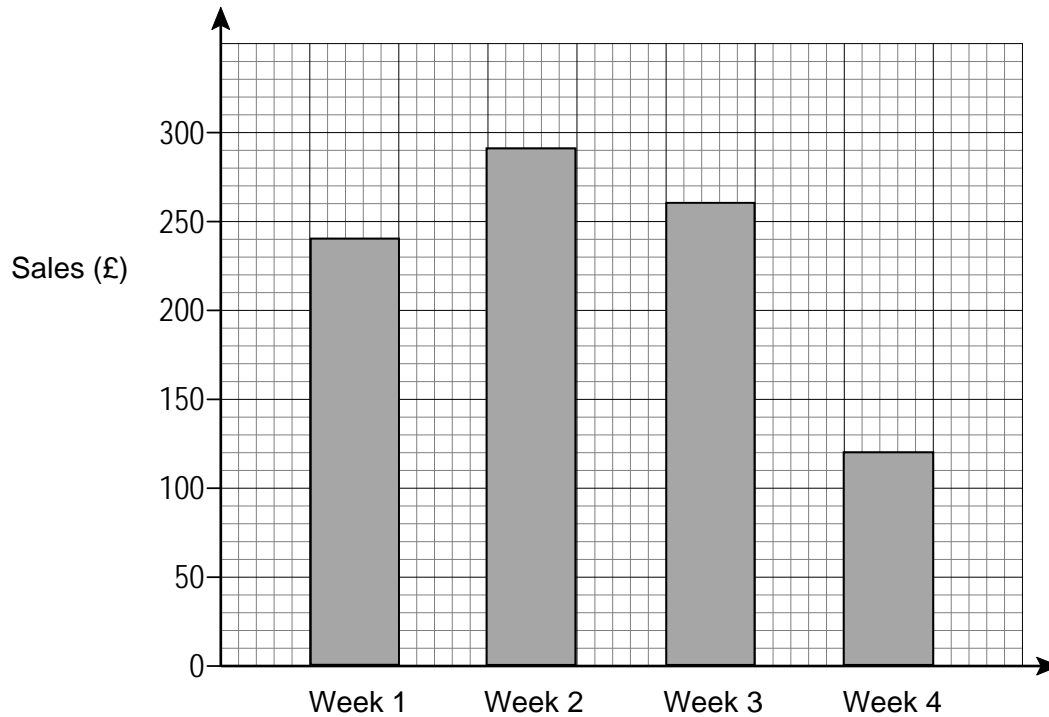

Every week his costs are £87.50

7 (a) Work out his profit in Week 1

[2 marks]

Answer £ _____

7 (b) His sales in Week 4 were half of his sales in Week 1

Zayn says,

“This means that my profit in Week 4 was half of my profit in Week 1”

Is he correct?

You **must** show your working.

[2 marks]

8 Work out the value of $5x + 9y$ when $x = 7$ and $y = -2$

[2 marks]

Answer _____

9 The points $(-1, 0)$ and $(1, 4)$ are the diagonally opposite corners of a square.

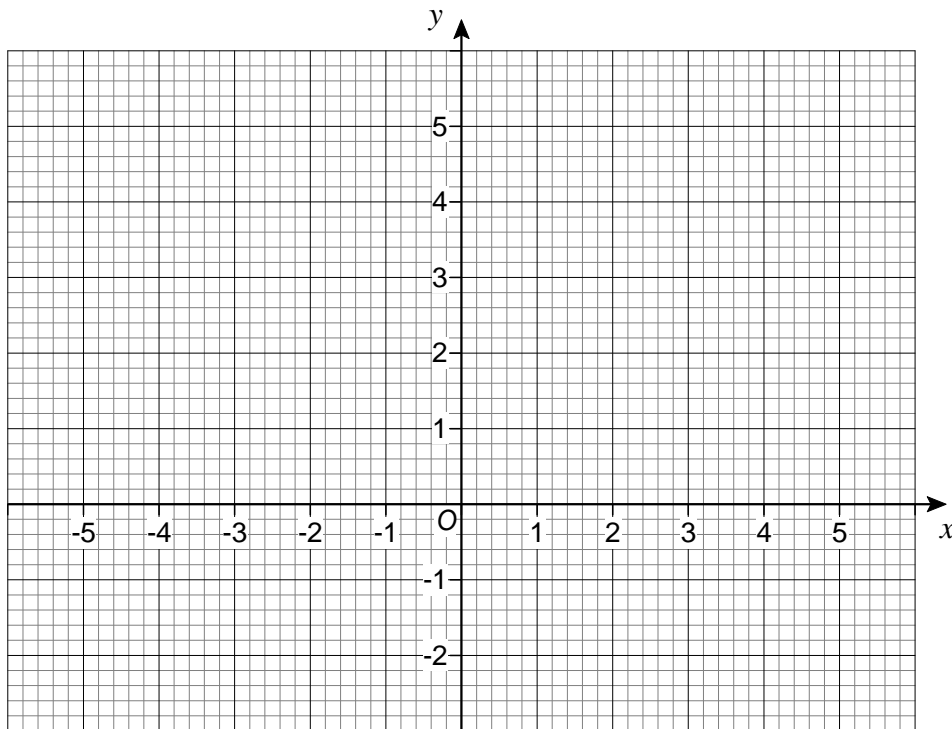

Work out the coordinates of the other **two** corners of the square.

[2 marks]

Answer (_____ , _____) and (_____ , _____)

- 10** In an experiment, different masses are hung on a spring.

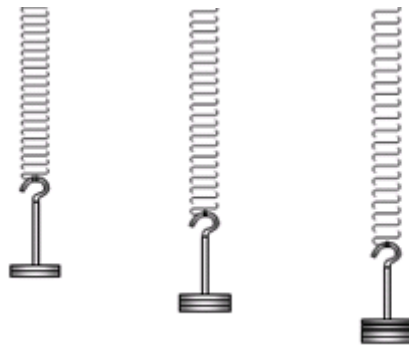

The length of the spring is measured for each mass.

Mass (g)	10	20	30	40
Length (cm)	20.8	21.6	22.4	23.2

- 10 (a)** Draw a graph to show the length of the spring for masses from 10 g to 40 g

[2 marks]

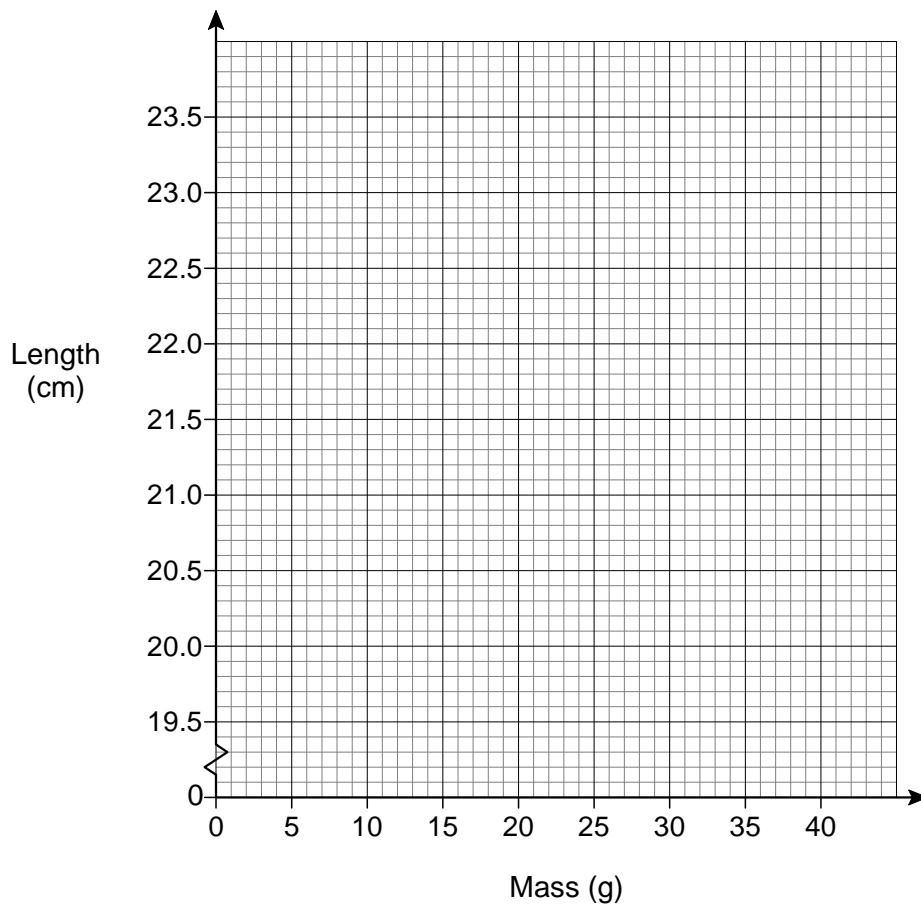

10 (b) Estimate the length of the spring with no mass hung on it.

[1 mark]

Answer _____ cm

10 (c) How much longer is the spring with a 35 g mass than with a 15 g mass?

[2 marks]

Answer _____ cm

Turn over for the next question

- 11 A sequence of patterns uses grey squares and white squares.
Here are the first four patterns.

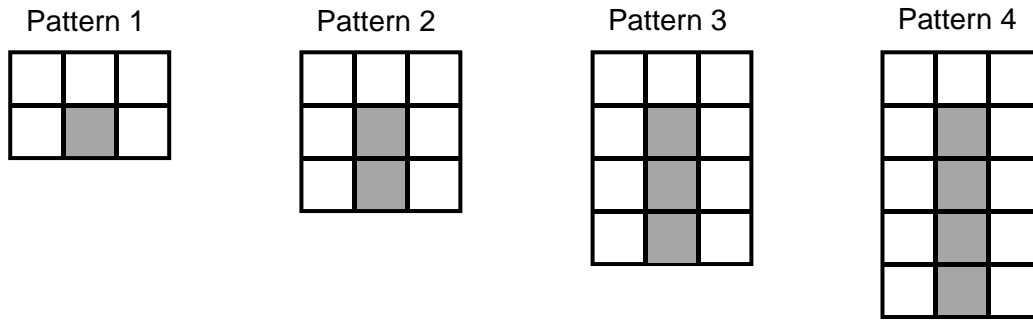

- 11 (a) Work out the **total** number of squares in Pattern 100

[3 marks]

Answer _____

11 (b) Complete this number machine for the sequence of patterns.

[1 mark]

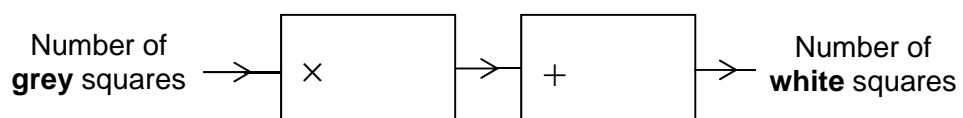

Turn over for the next question

12 In Scotland, squirrels are red or grey in the ratio red : grey = $1 : 2\frac{1}{2}$

12 (a) What fraction of the squirrels in Scotland are red?

[2 marks]

Answer _____

12 (b) In Scotland there are 120 000 red squirrels.

How many squirrels are there altogether in Scotland?

[2 marks]

Answer _____

- 13** Hayley and Tom have £2000 to spend on food at their wedding.
Here are their two options.

Wonderful Weddings!

Normal price £32 per person

Special offer

10% off

Kim the Caterer

Number of people	Price per person
100 & over	£24.50
80 to 99	£26.50
60 to 79	£28.50
up to 59	£30.50

Work out the **maximum** number of people they can pay for.

Show working to compare the maximum number of people for **both** options.

[5 marks]

Answer _____

14 Solve $4(x + 5) = 15$

[3 marks]

$x =$ _____

15 The mass of 40 cm^3 of copper is 356 grams.
Work out the mass of 90 cm^3 of copper.

[2 marks]

Answer _____ grams

- 16** 24 boys, 45 girls and 281 adults are the members of a badminton club.
50 more children join the club.
The number of girls is **now** 18% of the total number of members.

How many of the 50 children were **boys**?

[4 marks]

Answer _____

Turn over for the next question

- 17 The table shows information about the marks of 30 students in a test.

Mark	Frequency
14	2
15	10
16	2
17	3
18	13
	Total = 30

Students who scored less than the mean mark have to retake the test.

How many students have to retake the test?

You **must** show your working.

[3 marks]

Answer _____

- 18** Work out the square root of 100 million.
Circle your answer.

[1 mark]

1000

10 000

100 000

1 000 000

- 19** $\mathbf{a} = \begin{pmatrix} 5 \\ -2 \end{pmatrix}$ and $\mathbf{b} = \begin{pmatrix} -2 \\ 3 \end{pmatrix}$

Circle the vector $\mathbf{a} - \mathbf{b}$

[1 mark]

$\begin{pmatrix} -3 \\ -5 \end{pmatrix}$

$\begin{pmatrix} 7 \\ 1 \end{pmatrix}$

$\begin{pmatrix} 3 \\ 1 \end{pmatrix}$

$\begin{pmatrix} 7 \\ -5 \end{pmatrix}$

- 20** Circle the decimal that is closest in value to $\frac{2}{3}$

[1 mark]

0.6

0.66

0.667

0.67

Turn over for the next question

21 When $x^2 = 16$ the **only** value that x can be is 4

Is this true or false?

Tick a box.

[1 mark]

True False

Reason _____

22 In 1999 the minimum wage for adults was £3.60 per hour.

In 2013 it was £6.31 per hour.

Work out the percentage increase in the minimum wage.

[3 marks]

Answer _____ %

23 Use ruler and compasses to answer this question.

Point P is

- the same distance from AB and AD
- 6 cm from C .

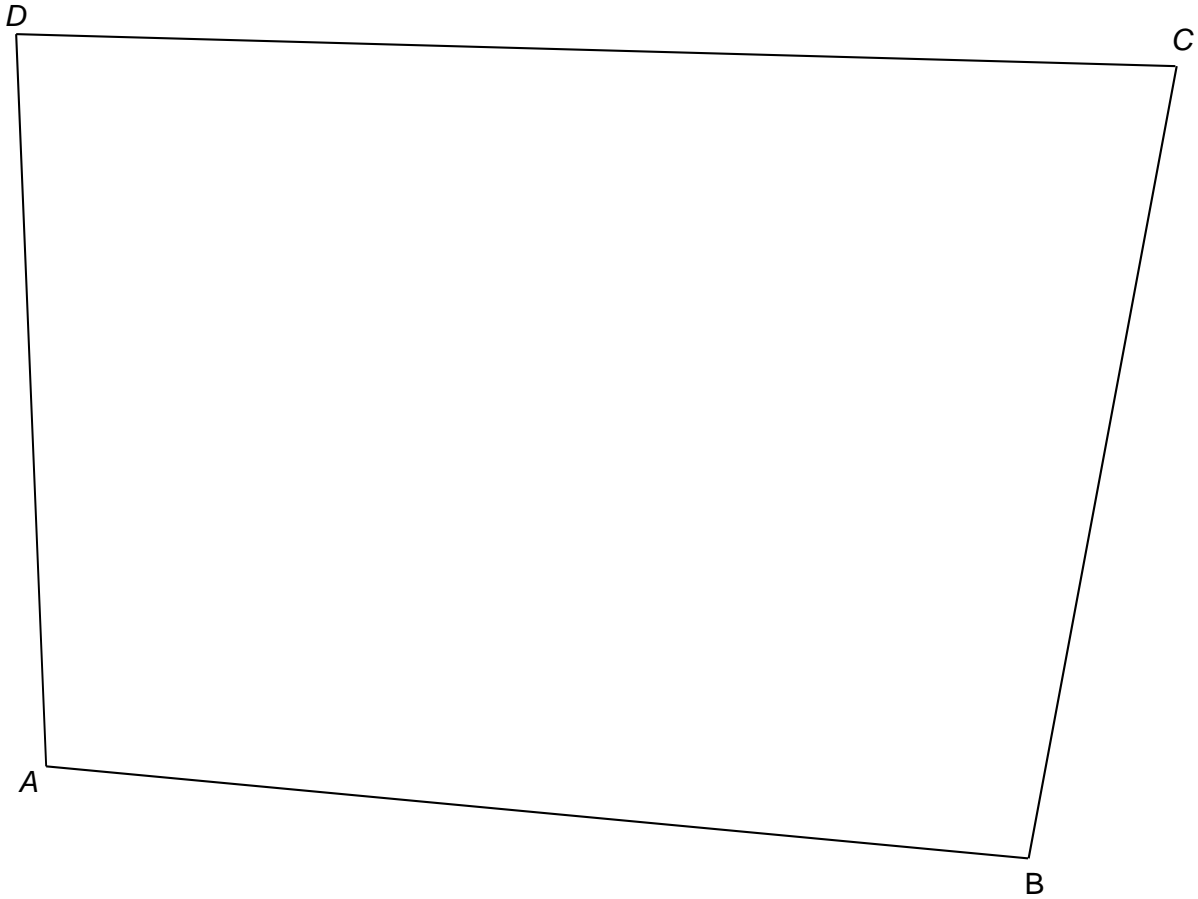

Show the position of P on the diagram.

[3 marks]

Turn over for the next question

24 (a) Use your calculator to work out $19.42^2 - \sqrt[3]{1006} \div 4.95$

Write down your full calculator display.

[1 mark]

Answer _____

24 (b) Use approximations to check that your answer to part (a) is sensible.
You **must** show your working.

[2 marks]

26

 y is directly proportional to x .

Which graph shows this?

Circle the correct letter.

[1 mark]

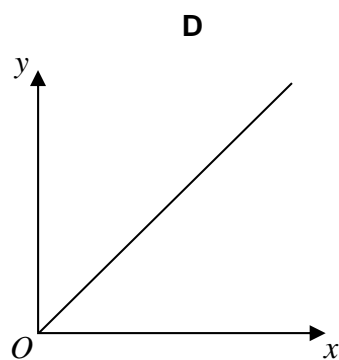
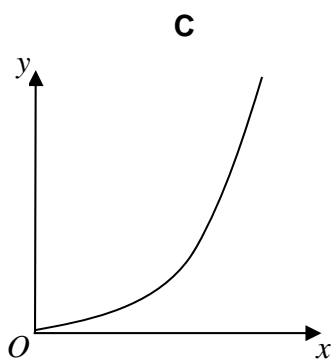
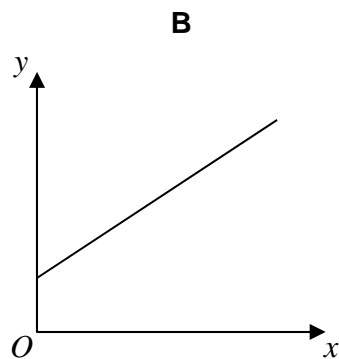
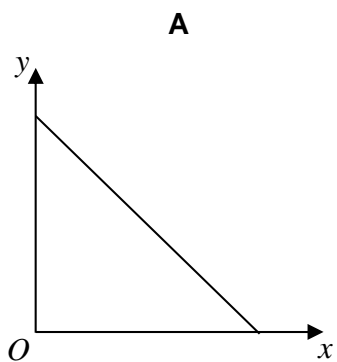

- 27 A bag contains counters that are red, blue, green or yellow.

	red	blue	green	yellow
Number of counters	9	$3x$	$x - 5$	$2x$

A counter is chosen at random.

The probability it is **red** is $\frac{9}{100}$

Work out the probability it is green.

[4 marks]

Answer _____

Turn over for the next question

28 The pressure at sea level is 101 325 Pascals.

Any rise of 1 km above sea level decreases the pressure by 14%

For example,

at 3 km above sea level the pressure is 14% less than at 2 km

Work out the pressure at 4 km above sea level.

Give your answer to 2 significant figures.

[4 marks]

Answer _____ Pascals

29

ABC is a triangle with $AB = AC$

BA is parallel to CD .

Not drawn
accurately

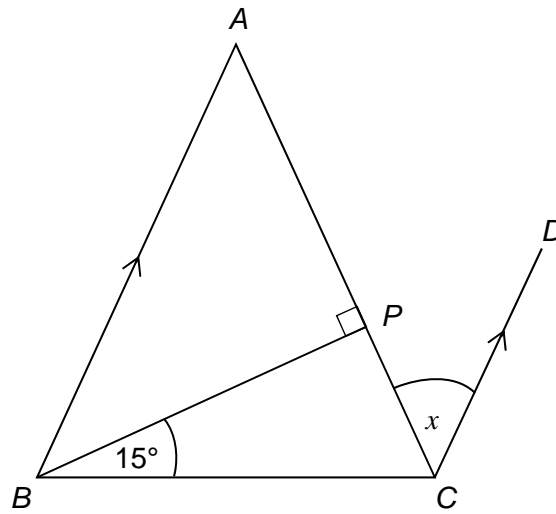

Show that angle $x = 30^\circ$

[3 marks]

END OF QUESTIONS

There are no questions printed on this page

**DO NOT WRITE ON THIS PAGE
ANSWER IN THE SPACES PROVIDED**

GCSE Mathematics Specification (8300/3H) Paper 3 Higher tier

H

Date

Morning

1 hour 30 minutes

Materials

For this paper you must have:

- a calculator
- mathematical instruments.



Instructions

- Use black ink or black ball-point pen. Draw diagrams in pencil.
- Fill in the boxes at the bottom of this page.
- Answer **all** questions.
- You must answer the questions in the spaces provided. Do not write outside the box around each page or on blank pages.
- Do all rough work in this book.
- In all calculations, show clearly how you work out your answer.

Information

- The marks for questions are shown in brackets.
- The maximum mark for this paper is 80.
- You may ask for more answer paper, graph paper and tracing paper. These must be tagged securely to this answer book.

Please write clearly, in block capitals, to allow character computer recognition.

Centre number

Candidate number

Surname

Forename(s)

Candidate signature _____

Answer **all** questions in the spaces provided.

- 1** Work out the square root of 100 million.
Circle your answer.

[1 mark]

1000

10 000

100 000

1 000 000

- 2** $\mathbf{a} = \begin{pmatrix} 5 \\ -2 \end{pmatrix}$ and $\mathbf{b} = \begin{pmatrix} -2 \\ 3 \end{pmatrix}$

Circle the vector $\mathbf{a} - \mathbf{b}$

[1 mark]

$\begin{pmatrix} -3 \\ -5 \end{pmatrix}$

$\begin{pmatrix} 7 \\ 1 \end{pmatrix}$

$\begin{pmatrix} 3 \\ 1 \end{pmatrix}$

$\begin{pmatrix} 7 \\ -5 \end{pmatrix}$

- 3** Circle the decimal that is closest in value to $\frac{2}{3}$

[1 mark]

0.6

0.66

0.667

0.67

4 y is directly proportional to x .

Which graph shows this?

Circle the correct letter.

[1 mark]

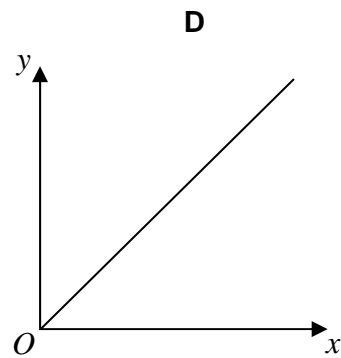
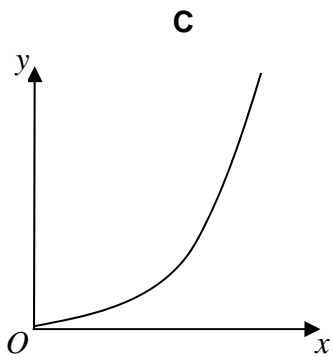
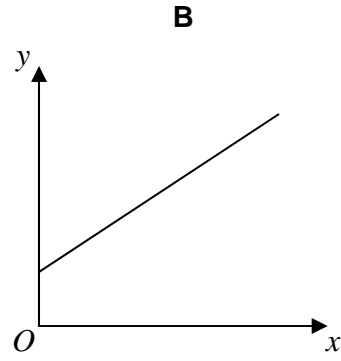
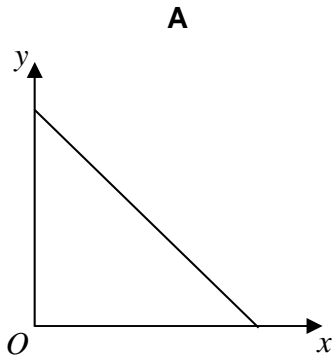

Turn over for the next question

- 5 In 1999 the minimum wage for adults was £3.60 per hour.
In 2013 it was £6.31 per hour.
Work out the percentage increase in the minimum wage.

[3 marks]

Answer _____ %

- 6 A bag contains counters that are red, blue, green or yellow.

	red	blue	green	yellow
Number of counters	9	$3x$	$x - 5$	$2x$

A counter is chosen at random.

The probability it is **red** is $\frac{9}{100}$

Work out the probability it is green.

[4 marks]

Answer _____

7 Use ruler and compasses to answer this question.

Point P is

- the same distance from AB and AD
- 6 cm from C .

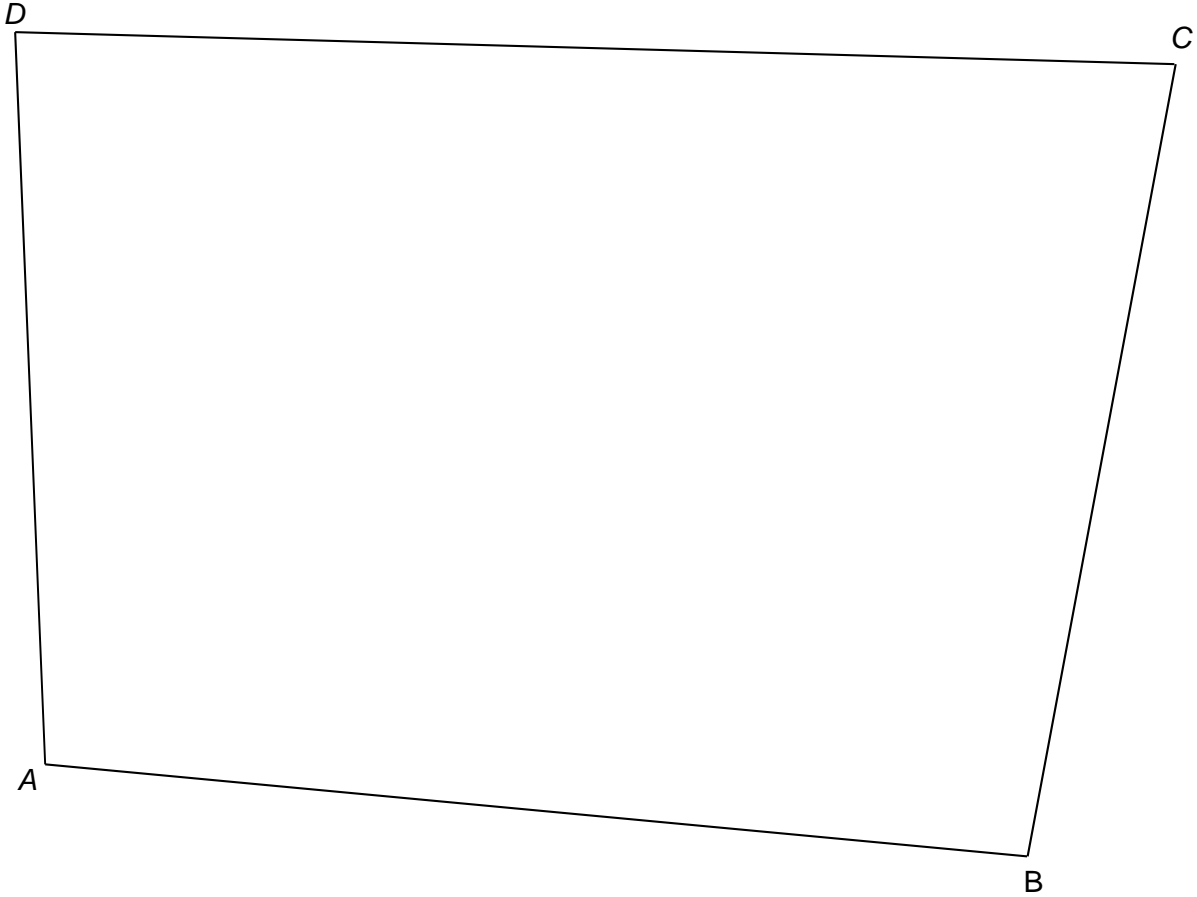

Show the position of P on the diagram.

[3 marks]

Turn over for the next question

- 8 (a) Use your calculator to work out $19.42^2 - \sqrt[3]{1006} \div 4.95$

Write down your full calculator display.

[1 mark]

Answer _____

- 8 (b) Use approximations to check that your answer to part (a) is sensible.
You **must** show your working.

[2 marks]

- 9 The exterior angle of a regular polygon is 45°
Circle the name of the regular polygon.

[1 mark]

pentagon

hexagon

octagon

decagon

- 10 ABC is a triangle with $AB = AC$
 BA is parallel to CD .

Not drawn
accurately

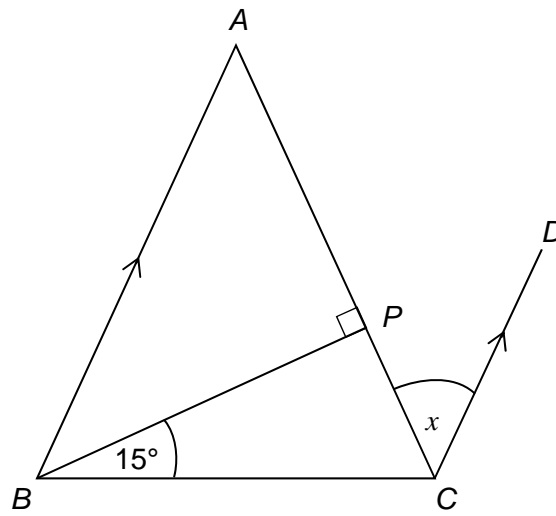

Show that angle $x = 30^\circ$

[3 marks]

11 The pressure at sea level is 101 325 Pascals.

Any rise of 1 km above sea level decreases the pressure by 14%

For example,

at 3 km above sea level the pressure is 14% less than at 2 km

Work out the pressure at 4 km above sea level.

Give your answer to 2 significant figures.

[4 marks]

Answer _____ Pascals

12 Tick whether each statement is true or false.

Give a reason for your answer.

12 (a) When $x^2 = 16$ the **only** value that x can be is 4

[1 mark]

True False

Reason _____

12 (b) When n is a positive integer, the value of $2n$ is **always** a factor of the value of $20n$.

[1 mark]

True False

Reason _____

12 (c) When y is positive, the value of y^2 is **always** greater than the value of y .

[1 mark]

True False

Reason _____

- 13 Here are the examination marks for 60 pupils.

Mark, m (%)	Frequency
$0 \leq m < 20$	8
$20 \leq m < 40$	9
$40 \leq m < 60$	21
$60 \leq m < 80$	10
$80 \leq m < 100$	12

Molly drew this cumulative frequency graph to show the data.

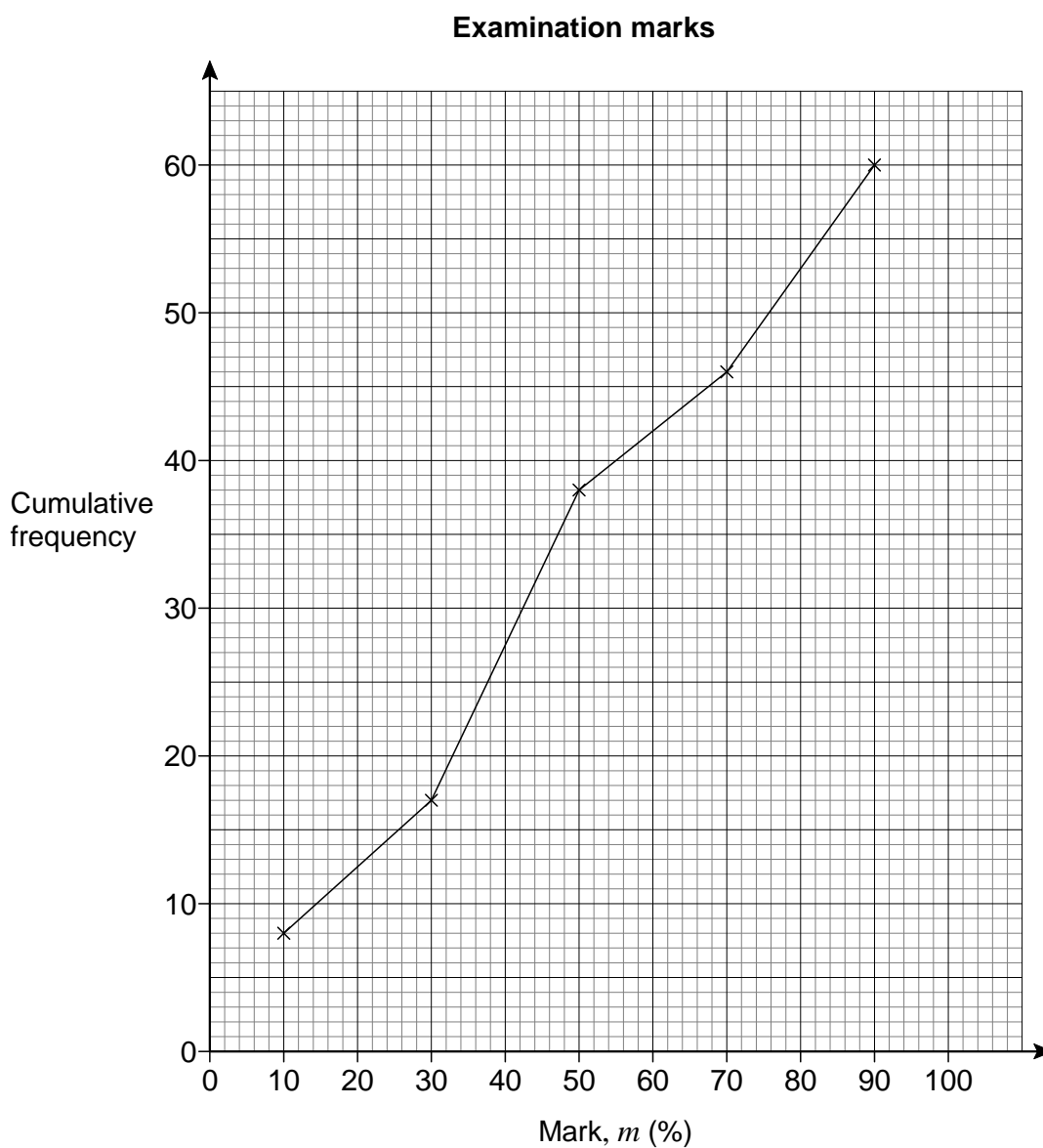

Make **two** criticisms of Molly's graph.

[2 marks]

Criticism 1 _____

Criticism 2 _____

Turn over for the next question

14 (a) The n th term of a sequence is $2^n + 2^{n-1}$

Work out the 10th term of the sequence.

[1 mark]

Answer _____

14 (b) The n th term of a different sequence is $4(2^n + 2^{n-1})$

Circle the expression that is equivalent to $4(2^n + 2^{n-1})$

[1 mark]

$$2^{n+2} + 2^{n+1}$$

$$2^{2n} + 2^{2(n-1)}$$

$$8^n + 8^{n-1}$$

$$2^{n+2} + 2^{n-1}$$

15

The diagram shows a design for a zipwire.

The zipwire will run between the top of two vertical posts, AB and CD .

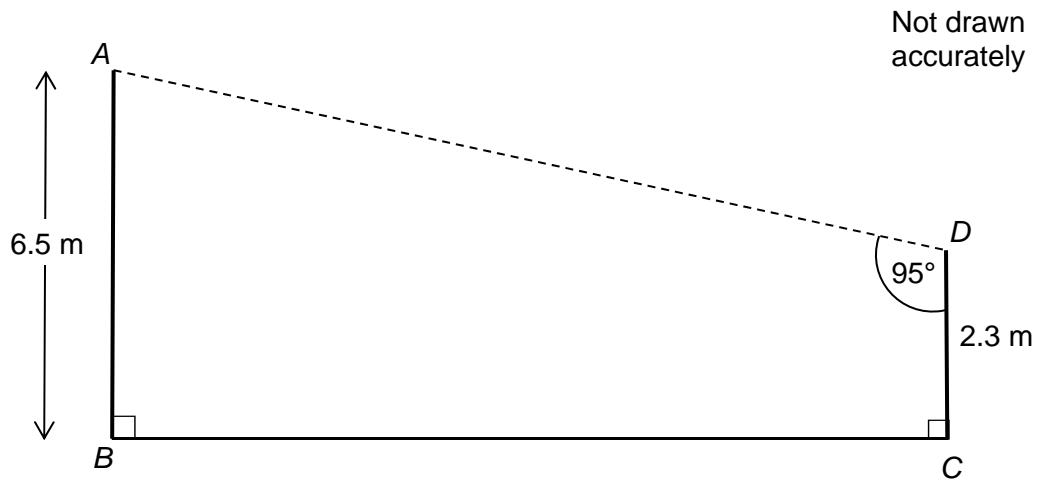

Work out the distance AD .

[4 marks]

Answer _____ m

16 During a game, players can win and lose counters.

At the start of the game

Rob, Tim and Zak share the counters in the ratio 5 : 6 : 7

At the end of the game

Rob, Tim and Zak share the **same number** of counters in the ratio 7 : 9 : 8

Show that Rob ends the game with more counters than he started with.

[3 marks]

17 Factorise $3x^2 + 14x + 8$

[2 marks]

Answer _____

19 Here are two function machines, **A** and **B**.

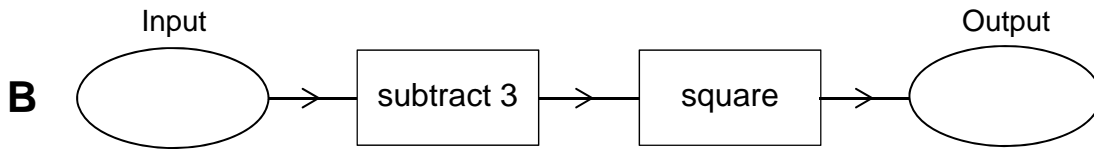
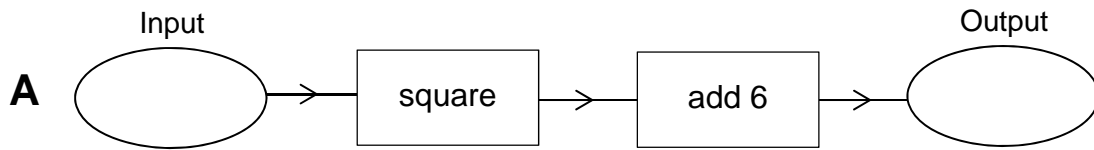

Both machines have the same input.

Work out the range of input values for which

the output of **A** is **less** than the output of **B**.

[4 marks]

Answer _____

20 In the triangle, angle y is obtuse.

Not drawn
accurately

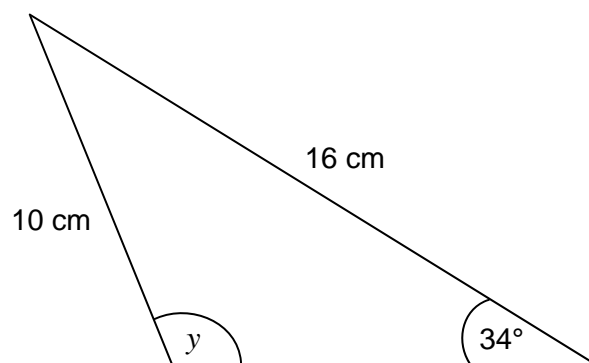

Work out the size of angle y .

[3 marks]

Answer _____ degrees

Turn over for the next question

- 21** A box is a cuboid with dimensions 27 cm by 15 cm by 20 cm
These dimensions are to the nearest **centimetre**.

DVD cases are cuboids with dimensions 1.5 cm by 14.3 cm by 19.2 cm
These dimensions are to the nearest **millimetre**.

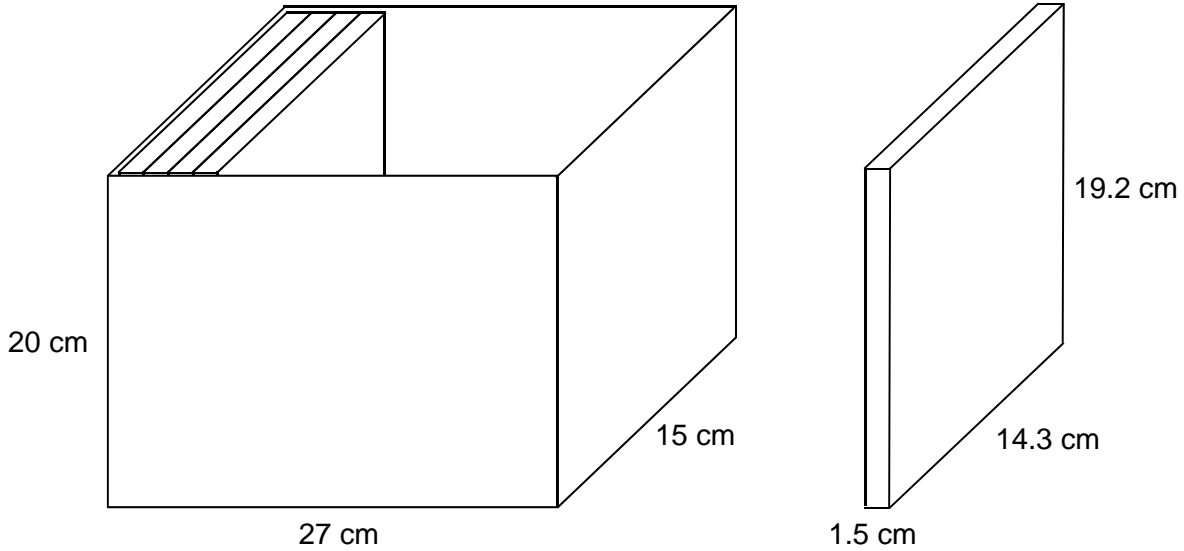

Show that 17 DVD cases, stacked as shown, will definitely fit in the box.

[4 marks]

23

A container is filled with water in 5 seconds.

The graph shows the depth of water, d cm, at time t seconds.

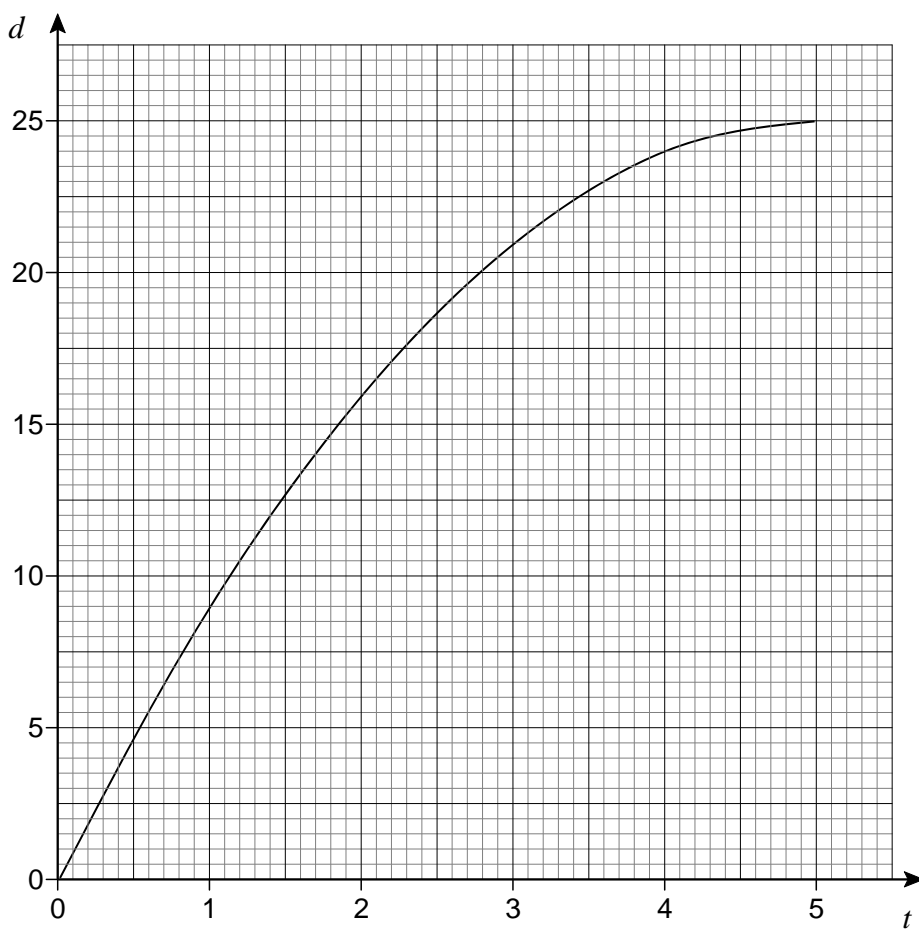

23 (a) The water flows into the container at a constant rate.

Which diagram represents the container?

Circle the correct letter.

[1 mark]

A

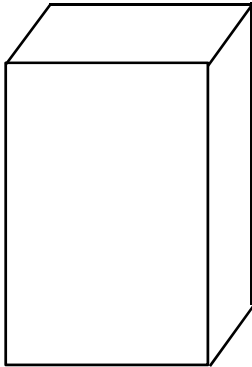

B

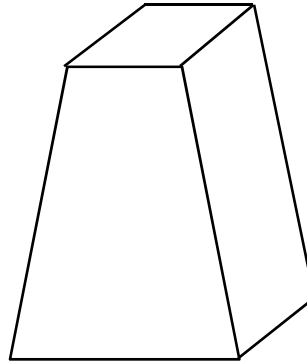

C

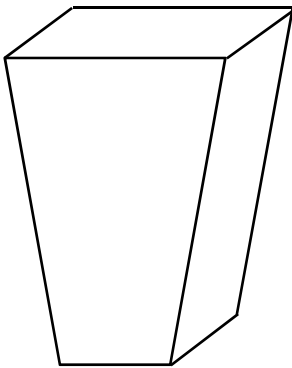

D

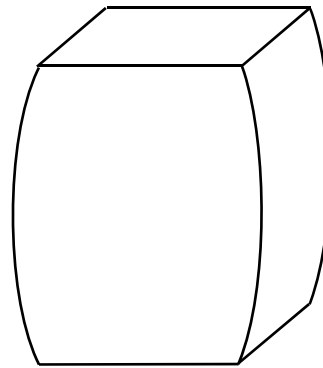

23 (b) Use the graph to estimate the rate at which the depth of water is increasing at 3 seconds.

You **must** show your working.

[2 marks]

Answer _____ cm/s

24 Amina and Ben had a cycle race.

Here is Amina's speed-time graph from the start of the race.

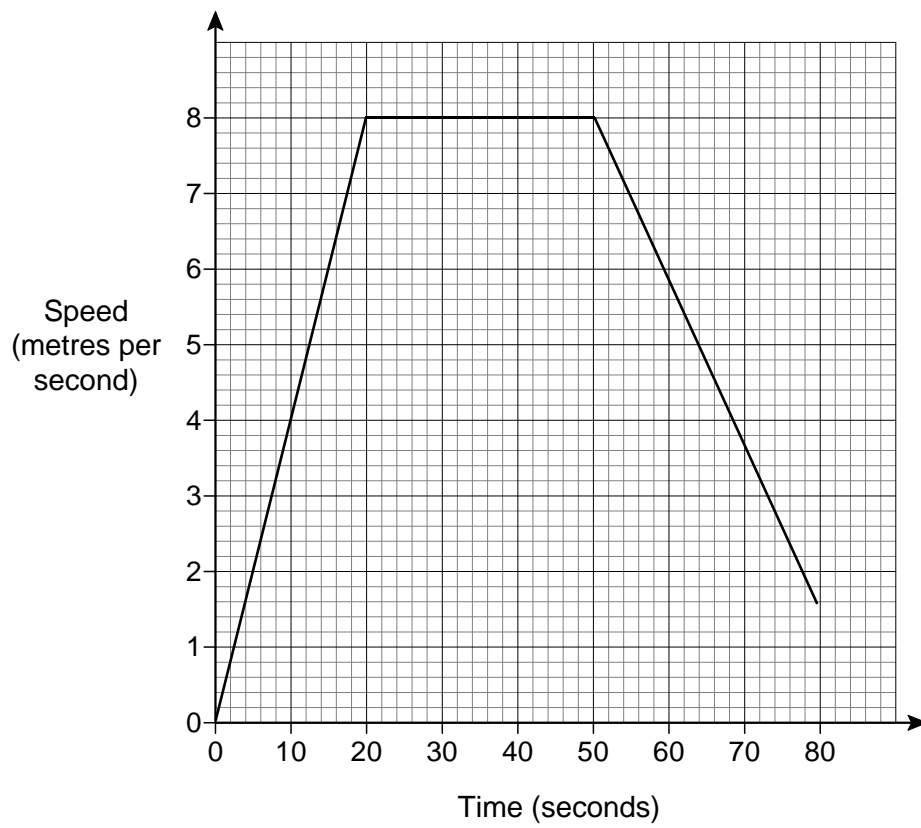

- 24** The distance of the race was 400 metres.
Ben cycled the 400 metres in 64 seconds.
Who won the race?
You **must** show your working.

[4 marks]

Answer _____

Turn over for the next question

25 In triangle ABC

M is the midpoint of AC

N is the point on BC where $BN : NC = 2 : 3$

$$\vec{AC} = 2\mathbf{a}$$

$$\vec{AB} = 3\mathbf{b}$$

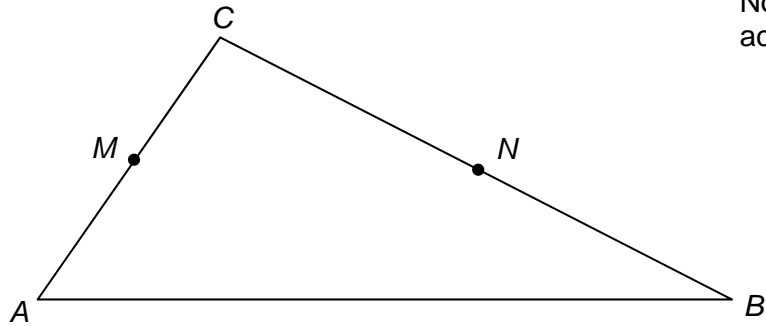

Not drawn
accurately

25 (a) Work out \vec{MN} in terms of \mathbf{a} and \mathbf{b} .
Give your answer in its simplest form.

[3 marks]

Answer _____

25 (b) Use your answer to part (a) to explain why MN is **not** parallel to AB .

[1 mark]

26 An approximate solution to an equation is found using this iterative process.

$$x_{n+1} = \frac{(x_n)^3 - 3}{8} \quad \text{and} \quad x_1 = -1$$

26 (a) Work out the values of x_2 and x_3

[2 marks]

$$x_2 = \underline{\hspace{10em}}$$

$$x_3 = \underline{\hspace{10em}}$$

26 (b) Work out the solution to 6 decimal places.

[1 mark]

$$x = \underline{\hspace{10em}}$$

27 The curve with equation $y = x^2 - 5x + 2$ is reflected in the x -axis.

Circle the equation of the reflected curve.

[1 mark]

$$y = x^2 - 5x - 2$$

$$y = -x^2 + 5x + 2$$

$$y = -x^2 + 5x - 2$$

$$y = x^2 + 5x + 2$$

- 28 The diagram shows a line joining O to P .

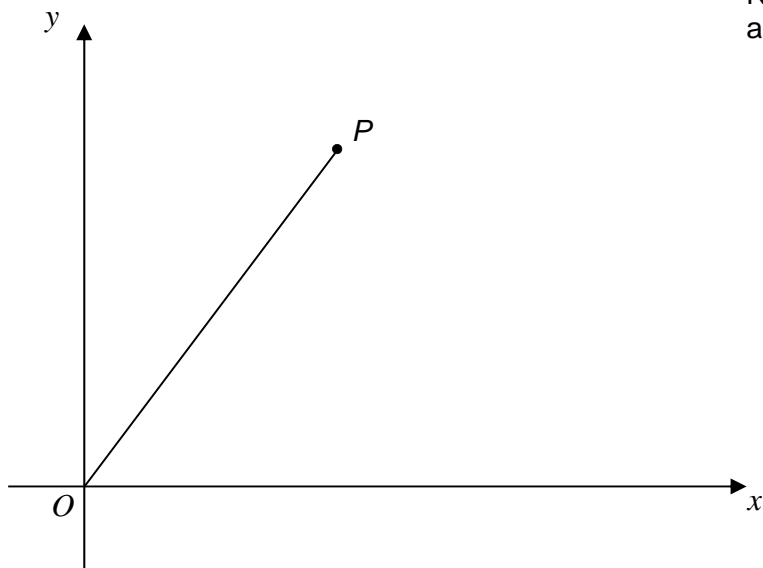

Not drawn
accurately

The gradient of the line is 2

The length of the line is $\sqrt{2645}$

Work out the coordinates of P .

[4 marks]

Answer (_____ , _____)

END OF QUESTIONS

There are no questions printed on this page

**DO NOT WRITE ON THIS PAGE
ANSWER IN THE SPACES PROVIDED**