

Mark Scheme Summer 2009

GCE

GCSE Manufacturing - 2351

Edexcel is one of the leading examining and awarding bodies in the UK and throughout the world. We provide a wide range of qualifications including academic, vocational, occupational and specific programmes for employers.

Through a network of UK and overseas offices, Edexcel's centres receive the support they need to help them deliver their education and training programmes to learners.

For further information, please call our GCE line on 0844 576 0025, our GCSE team on 0844 576 0027, or visit our website at www.edexcel.com.

If you have any subject specific questions about the content of this Mark Scheme that require the help of a subject specialist, you may find our **Ask The Expert** email service helpful.

Ask The Expert can be accessed online at the following link:

<http://www.edexcel.com/Aboutus/contact-us/>

Summer 2009

Publications Code UG021511

All the material in this publication is copyright

© Edexcel Ltd 2009

Contents

1. Unit 5318/01	5
2. Unit 5318/02	34
3. Unit 5318/03	64
4. Unit 5318/04	94
5. Unit 5318/05	122
6. Unit 5318/06	152

Section A

Question Number	Answer	Mark
1(a)	<ul style="list-style-type: none"> • Lottery ticket • Football cards <p><i>If three boxes ticked max marks = 1 mark. If 4 boxes or more ticked no marks.</i></p> <p style="text-align: right;">(2 x 1)</p>	(2)
1(b)	<ul style="list-style-type: none"> • Road atlas • Science textbook <p><i>If three boxes ticked max marks = 1 mark. If 4 boxes or more ticked no marks.</i></p> <p style="text-align: right;">(2 x 1)</p>	(2)

Question Number	Answer	Mark
2(a)	<ul style="list-style-type: none"> • Craft knife • Cutting blade • Stanley knife • Knife • Scalpel • Scriber <p><i>Accept any recognisable spelling (phonetic) of the answers above.</i></p> <p style="text-align: right;">(1 x 1)</p>	(1)
	<ul style="list-style-type: none"> • Template or Stencil (accept any answer that makes reference to a specific template or stencil) e.g. <p>Circle template Stencil for creating circles</p> <p><i>Accept any recognisable spelling (phonetic) of the answers above.</i></p> <p style="text-align: right;">(1 x 1)</p>	(1)

<p>2(b)</p>	<p>An answer that makes reference to two of the following points:</p> <ul style="list-style-type: none"> • Cutting paper • Accurate cutting/cutting to correct dimensions • Cutting in multiples • Cutting a straight edge <p>e.g. Used to cut paper (1) to accurate dimensions (1)</p> <p style="text-align: right;">(2 x 1)</p>	<p style="text-align: center;">(2)</p>
	<p>An answer that makes reference to two of the following points:</p> <ul style="list-style-type: none"> • Drawing curved lines • Consistent drawing of curved lines • Can be bent to desired shape • For special lines • For drawing irregular shapes <p>Eg. For drawing curved lines (1) in a consistent manner(1)</p> <p style="text-align: right;">(2 x 1)</p>	<p style="text-align: center;">(2)</p>

Question Number	Answer	Mark														
3	<p data-bbox="391 324 1157 436"><i>No mark awarded where 2 or more lines are drawn from a term. Lines do not have to be straight but term and key area must be clearly linked.</i></p> <div data-bbox="391 459 1173 1467"> <table border="0"> <thead> <tr> <th data-bbox="391 459 790 504">Term</th> <th data-bbox="790 459 1173 504">Key Area</th> </tr> </thead> <tbody> <tr> <td data-bbox="391 504 638 660">Continuous operation</td> <td data-bbox="790 504 1173 728">Information & Communications Technology (ICT)</td> </tr> <tr> <td data-bbox="391 694 638 828">Computer-aided design (CAD)</td> <td data-bbox="790 728 1173 884">Control technology</td> </tr> <tr> <td data-bbox="391 862 638 963">Databases</td> <td data-bbox="790 884 1173 1041">Control technology</td> </tr> <tr> <td data-bbox="391 1019 638 1120">Polymers</td> <td data-bbox="790 1041 1173 1198">Modern materials</td> </tr> <tr> <td data-bbox="391 1198 638 1299">Automation</td> <td data-bbox="790 1198 1173 1355">Modern materials</td> </tr> <tr> <td data-bbox="391 1366 638 1467">Composites</td> <td data-bbox="790 1355 1173 1512">Modern materials</td> </tr> </tbody> </table> </div> <p data-bbox="1077 1512 1165 1556">(6 x 1)</p>	Term	Key Area	Continuous operation	Information & Communications Technology (ICT)	Computer-aided design (CAD)	Control technology	Databases	Control technology	Polymers	Modern materials	Automation	Modern materials	Composites	Modern materials	(6)
Term	Key Area															
Continuous operation	Information & Communications Technology (ICT)															
Computer-aided design (CAD)	Control technology															
Databases	Control technology															
Polymers	Modern materials															
Automation	Modern materials															
Composites	Modern materials															

Question Number	Answer	Mark
4(a)(i)	<p>Appropriate product such as e.g.</p> <ul style="list-style-type: none"> • Fast food packaging • Backing board • Blister packaging • Tickets • CD/DVD booklet • Food and drink packaging • Forehead thermometer • Greeting card • Business card • Calendar • Paperback book • Point of sale display • Board game • Tetrapak <p><i>Accept brand name of a specific product.</i></p> <p><i>This list is not exhaustive; accept any product associated with the printing and publishing paper and board sector.</i></p> <p style="text-align: right;">(1 x 1)</p>	(1)
4(a)(ii)	<p>Appropriate explanation of what the product does, may include reference to features and function</p> <p>Examples:</p> <ul style="list-style-type: none"> • CD/DVD booklet - it provides information (1) and advertises the product (1) and/or makes the product look aesthetically pleasing (1) • Greeting card - to send to people (1) on an occasion (1) • Point of sale display - to advertise (1) to provide information (1) <p><i>If product given in 4(a)(i) is not from this sector but is from one of the other engineering manufacturing sectors then allow follow through, up to one mark.</i></p> <p><i>No answer to 4(a)(i) no mark for 4(a)(ii)</i></p> <p style="text-align: right;">(2 x 1)</p>	(2)

Question Number	Answer	Mark
4(b)(i)	<ul style="list-style-type: none"> • design (1) marketing (1) production planning (1) materials - supply and control (1) processing/production (1) assembly/finishing (1) packaging/dispatch (1) <p><i>If product given in 4(a) (i) is not from this sector but is from one of the other engineering/manufacturing sectors then allow follow through.</i></p> <p><i>No answer to 4(a)(i) no marks for 4(b)(i)</i></p> <p><i>Accept a process that is within any of the stages e.g. Vacuum forming / shearing or cutting / folding /automatic packaging / printing etc.; must be appropriate to the product stated in 4(a)(i)</i></p> <p style="text-align: right;">(1 x 1)</p>	(1)

Question Number	Answer	Mark
4(b)(ii)	<p>One mark for identifying advantage One mark for why</p> <p>Appropriate advantage to the manufacturer e.g.</p> <p>Design, marketing, production planning, materials - supply and control, processing/production, assembly/finishing, packaging/dispatch</p> <p>design</p> <ul style="list-style-type: none"> • better designs (1) - can link other information into the process (1), or best designs can be maximised by simulation (1) • faster (1) - many CAD features such as copy, array can be used (1) or if mistakes made they can be quickly rectified (1) <p>marketing</p> <ul style="list-style-type: none"> • accurate information (1) - less mistakes made in capturing data (1) • better/accessible knowledge base (1) - easy data entry/data analysed easy (1) <p>production planning</p> <ul style="list-style-type: none"> • speed (1) - faster than human application (1) <p>materials - supply and control</p> <ul style="list-style-type: none"> • buy best available materials (1) - use of internet (1) • waste control (1) - by monitoring processes and quality control of processes (1) <p>processing/production</p> <p>Answer could relate to the application of CAM and control technology such as:-</p> <ul style="list-style-type: none"> • energy conservation (1) - by control of energy into process (1) • waste control (1) - by monitoring processes and quality control of processes(1) • competitiveness (1) - faster rates of production/application of CAM techniques (1) • product consistency (1) - by control of processes (1) • cost control (1) - by less waste/faulty parts (1) • efficiency (1) - by less waste/faulty parts (1) • speed (1) - faster than human application (1) 	

	<p>assembly/finishing Answer could relate to the application of CAM and control technology such as:-</p> <ul style="list-style-type: none"> • energy conservation (1) - by control of energy into process (1) • waste control (1) - by monitoring processes and quality control of processes (1) • product consistency (1) - by control of processes (1) • cost control (1) - by less waste/faulty parts (1) • efficiency (1) - by less waste/faulty parts (1) • speed (1) - faster than human application (1) <p>packaging/dispatch Answer could relate to the application of CAM and control technology such as:-</p> <ul style="list-style-type: none"> • packaging consistency (1) - by control of processes (1) • cost control (1) - by less waste/faulty parts (1) • efficiency (1) - by less waste/faulty parts (1) • speed (1) - faster than human application (1) • energy conservation (1) - by control of energy into process (1) • waste control (1) - by monitoring processes and quality control of processes (1) <p><i>Low response (1) or two low responses (2) or detailed response (2)</i> <i>If the answer in part 4(b)(i) is not a manufacturing stage allow follow through up to 2 marks.</i></p> <p><i>No answer to 4(b)(i) no marks for 4(b)(ii)</i></p>	<p style="text-align: right;">(1 x 1) + (1 x 1) (2)</p>
--	--	--

Question Number	Answer	Mark
4(c)(i)	<ul style="list-style-type: none"> • Thermo-chromic inks (1), phosphorescent pigments (1) • Polymorph (1) • Laminate (1) • Holographic card (1), packaging laminates (1) • Coated card (1) • Bleed proof card (1) • Composites (1) • Polymer / plastic [although plastic is not technically correct accept the term 'plastic'] (1) • Various thermoplastics [PP, HDPE, PVC etc] (1) • Other appropriate materials / a material currently used for the given application <p>accept 'card', 'cardboard' or 'thermoplastic' or brand name of a specific material</p> <p><i>If product given in 4(a)(i) is not from this sector but is from one of the other engineering/manufacturing sectors then allow follow through.</i></p> <p><i>No answer to 4(a)(i) no marks for 4(c)(i)</i></p> <p style="text-align: right;">(1 x 1)</p>	(1)

<p>4(c)(ii)</p>	<p>One mark for identifying improvement One mark for how</p> <ul style="list-style-type: none"> • Functional characteristics - weight (1) / size (1) / shelf life (1) / protection (1) / rigidity (1) • Mechanical characteristics - strength (1) / durability (1) • Aesthetic characteristics - surface finish (1) / texture (1) / colour (1)/ appearance (1) • Intended markets - appeal to target audience (1) • Quality standards - consistency (1) / reliability (1) • Reduced weight (1) - better strength to weight ratio (1) • Reduced cost (1) - quicker / quicker to assemble (1) <p>Example: Bleed proof card in 4 c(i) - improves appearance of images /text (1) to appeal to target audience (1)</p> <p>Any other appropriate answer</p> <p><i>If answer in part 4(a)(i) is inappropriate but the material given in 4(c)(i) is appropriate allow follow through up to 2 marks. If no answer is given in part 4(a)(i) but the answer to part 4(c)(ii) relates to the material stated in part 4(c)(i) allow follow through up to 1 mark. If no answer or incorrect answer given in part 4(c)(i) no marks awarded for 4(c)(ii)</i></p> <p style="text-align: right;">(1 x 1)+(1 x 1)</p>	<p style="text-align: center;">(2)</p>
-----------------	---	--

Question Number	Answer	Mark
5(a)	<p>One mark for identifying the benefit One mark for how</p> <ul style="list-style-type: none"> • reduced ordering times (1) - automatic monitoring (1) • improve quality / accuracy (1) - control of processes (1) • reduced wastage (1) - optimise production methods (1) • improved efficiency (1) - faster / quicker throughput (1) • better process control (1) - in process monitoring (1) • reduced labour (1) - automated processes (1) • lower costs (1) - reduced wastage/faster/continuous production (1) • safer processes (1) - less manual input (1) <p><i>Do not accept 'easier', or 'faster/quicker' without explanation.</i></p> <p><i>Low response (1) or two low responses (2) or detailed response (2), for each of 3 benefits</i></p> <p style="text-align: right;">(2 x 1) + (2 x 1) + (2 x 1)</p>	(6)
5(b)	<p>One mark for identifying the reason One mark for how</p> <ul style="list-style-type: none"> • more consistent products (1) manufactured more accurately (1) • lower purchase price (1) faster production rates (1) • shorter order times (1) flexible methods used/variation in applied methods of production/faster production rates (1) • better quality/accurate product (1) processes controlled better/closer tolerances achieved (1) • customer satisfaction (1) better quality products produced (1) • consistent product (1) processes controlled better/closer tolerances achieved (1) • product guarantee (1) manufacturer has confidence in products produced/more reliable methods used (1) <p><i>Low response (1) or detailed statement (2) or two low responses (2)</i></p> <p style="text-align: right;">(1 x 1)+(1 x 1)</p>	(2)

Question Number	Answer	Mark
6(a)(i)	<p><i>Mark allocation - 1 mark for a relevant type</i></p> <ul style="list-style-type: none"> • Mobile phone / infrared / bluetooth • Email / messaging • Internet / wireless / Wi-fi • Video conferencing • Electronic point of sale (EPOS) • EDI • ISDN • Texting • Phone • Walkie talkie • Fax <p><i>Do not accept: TV, CAD, radio, computer / laptop / database</i></p> <p style="text-align: right;">(1 x 1)</p>	(1)

Question Number	Answer	Mark
6(a)(ii)	<p>One mark for identifying the benefit One mark for how</p> <ul style="list-style-type: none"> • Mobile phone - can talk to supplier when needed (1) flexibility / roaming location (1) • Email - can send or receive instructions that are accurate/can get or send written confirmation of instructions (1) immediate permanent record (1) • Internet - can order and check stock immediately/in real time (1) immediate vast access to information (1) • Video conferencing -no travel expenses / less time wasted in travelling (1) but has face to face contact (1) • Electronic point of sale (EPOS) - faster / more accurate control of stock (1) automatic reading of bar codes (1) • EDI - immediate transfer of information / no hard copies needed / less storage space (1) by use of secure on-line facilities (1) • ISDN - more data transferred in parallel (1) faster response rate with supplier through use of technology (1) • Texting - can refer back to what message was given (1) stored record of transaction (1) • Phone - can clarify and confirm without having to re-visit the discussion later (1) immediate two way conversation (1) • Walkie talkie - can clarify and confirm without having to re-visit the discussion later (1) immediate two way conversation / flexibility / roaming location / cost (1) • Fax - can refer back to what message was given (1) stored record of transaction (1) <p>Other benefits may be seen in the light of:</p> <p>Speed, accuracy, JIT, information retrieval, meets consumer demands, quicker, increased sales, reduced stock levels, reduced running costs, reduced lead times, calculation of sales, stock taking quicker/easier, storage space reduced or any other appropriate reason</p> <p><i>Answer must relate to technology given in 6(a)(i)</i></p> <p><i>If part 6(a)(i) is not answered or answered incorrectly, no mark awarded for 6(a)(ii).</i></p> <p style="text-align: right;">(1 x 1) + (1 x 1)</p>	(2)



Question Number	Answer	Mark
6(b)(i)	<p>One mark for identifying the way One mark for how</p> <ul style="list-style-type: none"> • Email can send or receive attachments (1) such as databases or spreadsheets (1) • Internet use in real time (1) can transfer sales information immediately by data entry (1) • Automated distributor use of electronic point of sale (EPOS) (1) can transfer sales data by automatic reading of bar codes (1) • Distributors can use EDI (1) for immediate transfer of sales information by use of secure on-line facilities (1) • Fax can be used to show highlight sales figures only without detail (1) by typing into the messaging system (1) <p><i>Detailed statement required for (2), two low responses (1)</i></p> <p style="text-align: right;">(1 x 1)+(1 x 1)</p>	(2)

<p>6(b)(ii)</p>	<p>One mark for each point made such as:</p> <p>Email</p> <ul style="list-style-type: none"> • distributor will have permanent record • can allow manufacturer to amend record sent • sends accurate information to respond to • can export information from own systems • limited ICT skills required • low cost <p>Internet</p> <ul style="list-style-type: none"> • doesn't need manual input • information given by the distributor is up to date • can use the internet information to plan marketing campaigns • online ordering • low cost <p>Distributors can use EDI</p> <ul style="list-style-type: none"> • doesn't need manual input • information given by the distributor is up to date • immediate response to sales • more responsive to stock movement • low cost <p>Fax</p> <ul style="list-style-type: none"> • does not give away all sales details to manufacturer • low cost • immediate hard copy • better medium for authorisation • limited ICT skills required <p><i>Do not accept any answers that suggest communications technology is free of charge or is no cost</i></p> <p><i>If part 6(b)(i) is not answered or answered incorrectly, but the answer to 6(b)(ii) identifies the communications technology, allow follow through up to 2 marks.</i></p> <p><i>1 x 1 mark low response, 3 x 1 mark 3 low responses or up to 3 for detailed response</i></p> <p style="text-align: right;">(3 x 1)</p>	<p style="text-align: center;">(3)</p>
-----------------	---	--

Question Number	Answer	Mark
7(a)	<p>One mark for each point made up to 2 marks such as:</p> <ul style="list-style-type: none"> • safer for operators/workers • can handle hazardous processes • does not suffer from fatigue • does not make errors relative to safety aspects • more efficient/does not tire • less waste • can detect production/process problems • can promote multiskilling • once set up correctly will continue to produce to a given standard <p><i>Any other appropriate response.</i> <i>Low responses (1) or detailed statement (2)</i> (1 x 1)+(1 x 1)</p>	(2)
7(b)	<p>One mark for each point made up to 2 marks such as:</p> <ul style="list-style-type: none"> • high set up costs • may have high running costs • may have high maintenance requirements • may not have flexibility in product range • may need close computer control to avoid malfunction <p><i>Any other appropriate response.</i> <i>Do not accept 'cost' without explanation</i> <i>Do not accept answers relating to less employees</i></p> <p><i>Low responses (1) or detailed statement (2)</i> (1 x 1) + (1 x 1)</p>	(2)
Total marks for section A		45

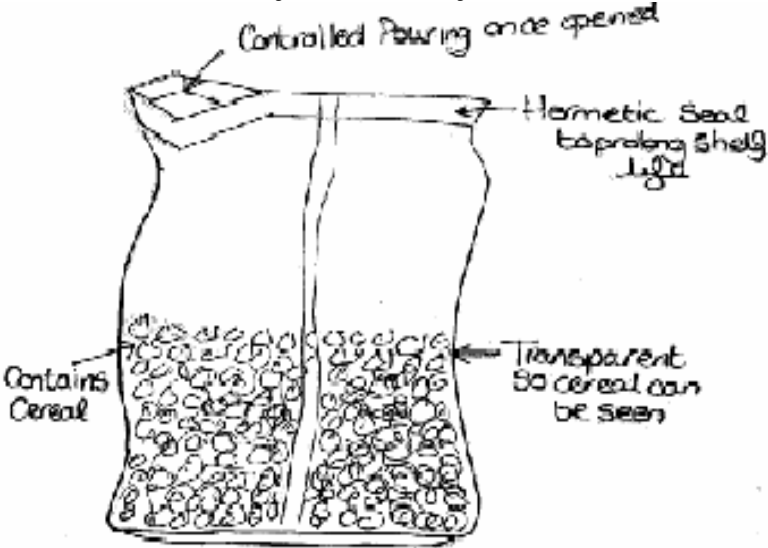
Section B

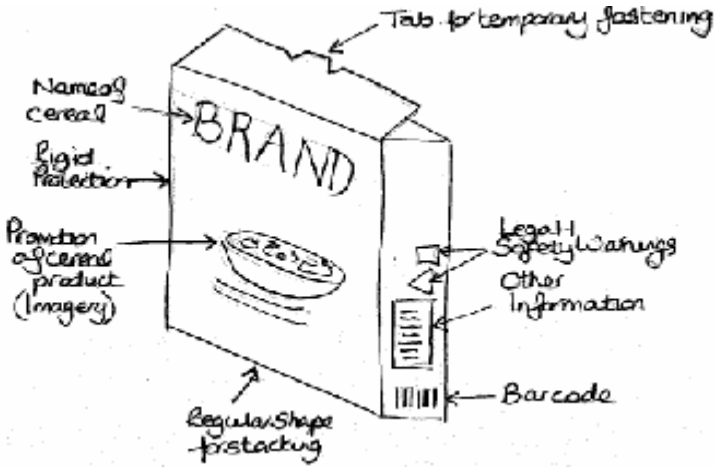
Question Number	Answer	Mark
8(a)	<p>An answer that makes reference to three of the following points:</p> <ul style="list-style-type: none"> • Inner bag contains (1) and protects (1) the cereals inside • Allows for hermetic sealing (1) to prolong shelf-life (1) • Allows for hygienic storage (1) of cereals before and after opening (1) • Inner bag is transparent (1) so the cereals can be seen by the consumer • Allows for controlled pouring (1) of cereals • Or any suitable <p><i>Answer must contain both notes and sketches. Max two marks if only notes or only sketches used.</i></p>  <p style="text-align: right;">(3 x 1)</p>	(3)

Question Number	Answer	Mark
8(b)	<p>An answer that makes reference to three of the following points:</p> <ul style="list-style-type: none"> • Protection of cereals (1) • Promotion of cereal product (1) • Contains branding (1) • Provides information about product (1) • Full colour printing possible (1) and printing effects (1) to provide visual imagery to attract target market group (1) • Contains legal and safety warnings (1) • Bar code for stock control (1) • Tab enables temporary fastening (1) • Enables easier stacking (1) or storage (1) due to regular shape (1) • Or any suitable <p><i>Answer must contain both notes and sketches. Max two marks if only notes or only sketches used</i></p>  <p><u>Birds eye view of box</u></p>  <p style="text-align: right;">(3 x 1)</p>	(3)

Question Number	Answer	Mark
9(a)(i)	<ul style="list-style-type: none"> • (Stage 4) Materials supply and control (accept 'Materials supply' or 'Materials control' but not 'supply' or 'control' on its own) • (Stage 6) Assembly and Finishing (accept 'Assembly' and 'Finishing' on its own) <p><i>Accept any recognisable spelling (phonetic) of the answers above.</i></p> <p style="text-align: right;">(1 x 1)+(1 x 1)</p>	(2)
9(a)(ii)	<ul style="list-style-type: none"> • Design • Stage 1 / stage one • 1 / one <p style="text-align: right;">(1 x 1)</p>	(1)

Question Number	Answer	Mark
9(b)(i)	<p>Appropriate descriptions including three of the following points (statements must be applicable to cereal packaging):</p> <p>Examples:</p> <ul style="list-style-type: none"> • developing a marketing plan (1) and using market research (1) to ensure graphics appeal to the target market (1) and cereals sell well to the target market (1) • developing a competitive edge (1) by providing a consistent (1) high quality product (1) at a price suitable for the target market (1) • advertising (1) and promotion (1) of the cereal through retailers (1) the media (1) and electronically (internet, e-mail) (1) • any other appropriate response <p>Up to 3 marks</p> <p><i>1 x 1 mark low response, 3 x 1 mark 3 low responses or up to 3 for detailed response</i></p> <p style="text-align: right;">(3 x 1)</p>	(3)

<p>9(b)(ii)</p>	<p>Appropriate descriptions including three of the following points (statements must be applicable to cereal packaging):</p> <ul style="list-style-type: none"> • Health and safety • Quality checks • Control points • Scheduling production • Converting order to production • Materials requirements • Labour requirements • Deadlines • Throughputs • Machinery / equipment requirement • Storing • Any other appropriate response <p>Example: The stage where the specification of the cereal packaging is used by the planning team to set out all operations and to schedule (1) the cereal packaging through the production department to meet the required delivery deadlines (1). This could include ordering any special materials or consumables (1) and stating machinery requirements (1). <i>Up to 3 marks</i></p> <p><i>1 x 1 mark low response, 3 x 1 mark 3 low responses or up to 3 for detailed response</i></p>	<p>(3 x 1)</p> <p>(3)</p>
-----------------	--	---------------------------

Question Number	Answer	Mark
10(a)(i)	<p>Specific materials to make the outer box</p> <ul style="list-style-type: none"> • Cardboard • Card • Duplex Board • Any other appropriate • Recycled card • Carton board <p><i>Do not accept generic answers, i.e. 'board' or 'hardboard'</i></p> <p><i>Accept any recognisable spelling (phonetic) of the answers above.</i></p> <p style="text-align: right;">(1 x 1)</p>	(1)
10(a)(ii)	<p>Specific materials to make the inner bag</p> <ul style="list-style-type: none"> • Polyethylene or PE • Polythene • LDPE • Low Density Polyethylene • Low Density Polythene • HDPE • High Density Polyethylene • High Density Polythene • Any other appropriate <p><i>Do not accept generic answers, i.e. 'plastic' or 'polymer'</i></p> <p><i>Accept any recognisable spelling (phonetic) of the answers above.</i></p> <p style="text-align: right;">(1 x 1)</p>	(1)

Question Number	Answer	Mark
10(b)(i)	<p>Any three of the following:</p> <ul style="list-style-type: none"> • Die cutting (outer box) • Folding (outer box) • Scoring (outer box) • Gluing (outer box) • Heat [hermetic] sealing (inner bag) • Guillotine cutting to size (inner bag) <p><i>1 mark per response up to 3</i></p> <p><i>Accept any recognisable spelling (phonetic) of the answers above.</i></p> <p style="text-align: right;">(3 x 1)</p>	(3)
10(b)(ii)	<p>Appropriate explanation including two of the following points:</p> <ul style="list-style-type: none"> • quick method/fast production rate • flexible process (can print on absorbent or non-absorbent substrates) • prints directly onto surface of substrate • inks are fast drying • inks are ready mixed • quick to clean up • little finishing required • unit costs are low • highly automated process • or similar <p>Examples Flexography is a high speed print process (1) that prints directly onto the surface (1) and is economical for very high volumes (1).</p> <p>After the initial set up costs, the unit cost is low (1) as it is a highly automated process (1) with a fast production rate (1).</p> <p><i>Up to 2 marks</i></p> <p><i>1 x 1 mark low response, or up to 2 marks for detailed response</i></p> <p style="text-align: right;">(2 x 1)</p>	(2)

Question Number	Answer	Mark
10(c)	<p>An explanation that makes reference to three of the following points:</p> <ul style="list-style-type: none"> • Aesthetics - high quality surface finishes, printing effects, colours textures etc. • Efficient and cost-effective mass production techniques - low unit costs, increased profit, larger product range, increased availability etc • Functionality - weight, size, increased shelf life, easier to reseal, more compact etc. • Mechanical characteristics - increased toughness, strength, durability etc. • Environmental characteristics - biodegradability/degradability, easier to disassemble etc. • Any other appropriate response <p><i>Up to 3 x 1 mark low responses or up to 3 marks for a detailed response</i></p> <p style="text-align: right;">(3 x 1)</p>	(3)

Question Number	Answer	Mark
11(a)(i)	<p>One application such as:</p> <ul style="list-style-type: none"> • check physical damage • size checks • functional checks • positional checks • dimensional checks • printing checks • hermetic seal checks • properties testing • or similar <p><i>Must be within production stage</i></p> <p style="text-align: right;">(1 x 1)</p>	(1)

11(a)(ii)	<p>Description of how such as:</p> <ul style="list-style-type: none"> • check physical damage - by visual inspection (1) and checking against prototype/first-off/template etc. (1) • size checks - by direct measurement or gauging/templates/optical sensors (1) and checking against drawing/specification/tolerances (1) • functional checks - dry assembly (1) and operation of tab/slot at top (1) • positional checks - use of crop marks (1) and target or registration marks (1) • dimensional checks - use of co-ordinate measuring machine (1) and analysing reported data (1) • printing checks - use of colour bar (1) or densitometer readings (1) • hermetic seal checks - ultrasound inspection (1) or terahertz radiation technique (1) • properties testing - in system testing (1) or destructive testing of final product (1) <p><i>Allow follow through up to 1 mark and if no answer in part 11(a)(i) up to 1 mark for a correct answer.</i></p> <p style="text-align: right;">(2 x 1)</p>	(2)
-----------	--	-----

Question Number	Answer	Mark
11(a)(iii)	<p>An explanation that makes reference to three of the following points:</p> <ul style="list-style-type: none"> • safer product to use • easier product to use • confidence in product reliability • consistent product • helps to maintain standards • no need to transfer contents to separate container • enables contents to remain fresh • product reliability • confidence in the company • lower prices • any other appropriate response <p><i>Must relate to the user</i></p> <p style="text-align: right;">(3 x 1)</p>	(3)

Question Number	Answer	Mark
11(b)(i)	<p>One mark for stating the type of computer control</p> <ul style="list-style-type: none"> • CAD • Controlling output • CAM • CIM • Robot • Programmable Logic Controllers (PLCs) • Conveyor system <p>Must be within production stage</p> <p style="text-align: right;">(1 x 1)</p>	(1)
11(b)(ii)	<p>Two marks for the description, for example:</p> <ul style="list-style-type: none"> • downloads images (1) - to presses (1) • modifies programmes / settings (1) - to alter process (1) • changes made are accounted for at different stages of the process (1) by linking design and manufacture (1) • PLCs - timed movement of automated machinery (1) or conveyors (1) <p><i>1 mark for low response or 2 marks for detailed response</i></p> <p><i>If no computer control is stated or inappropriate answer is given in 11(b)(i), allow follow through up to 1 mark for an appropriate description.</i></p> <p style="text-align: right;">(2 x 1)</p>	(2)

11(c)	<p>An explanation that makes reference to three of the following points:</p> <ul style="list-style-type: none"> • makes sure current specification is always used during manufacture • safer production methods • product reliability / consistent product • ensures standards are met • lower costs / control of costs / more profit • less scrap / more efficient • reduced changeover times • avoids faulty cereal packaging being assembled • early detection of problems • increased sales • user confidence / less returns • reduced waste • control of manufacturing process • less labour required • any other appropriate response <p><i>1 x 1 mark low response, 3 x 1 mark 3 low responses or up to 3 for detailed response</i></p> <p style="text-align: right;">(3 x 1)</p>	(3)
-------	---	-----

Question Number	Answer	Mark
12(a)(i)	<p>Any two of the following:</p> <ul style="list-style-type: none"> • drafting possible solutions • final design drawings • modelling possible solutions/final designs • conversion from 2D to 3D • use of websites/internet to investigate existing designs • to source materials/supplies/consumables • costing resource requirements • to communicate with client/customer • easy storage and retrieval of data/information • interaction with databases • or similar <p><i>1 mark per response up to 2</i></p> <p style="text-align: right;">(2 x 1)</p>	(2)

<p>12(a)(ii)</p>	<p>One mark for identifying the use One mark for how</p> <ul style="list-style-type: none"> • Development of labelling (1) and / by electronic tagging protocol (1) • Electronic monitoring (1) of some packaging processes (1) • Use of bar codes (1) to monitor packaging / dispatch of children's dungarees(1) • Use of software (1) to record / log output of cereal packaging (1) • Any other appropriate response <p><i>Do not accept answers that relate to the Production stage of the cereal packaging</i></p> <p style="text-align: right;">(1 x 1)+(1 x 1)</p>	<p style="text-align: center;">(2)</p>
<p>12(b)</p>	<p>One mark for identifying the benefit One mark for how</p> <ul style="list-style-type: none"> • Establishes a market database (1) shared with the manufacturer (1) • Has accurate costing information (1) shared with the manufacturer (1) / that can be manipulated easily (1) • Gives retailers the opportunity to match the market needs (1) with production of cereals/cereal packaging (1) • Any other appropriate response <p style="text-align: right;">(1 x 1)+(1 x 1)</p>	<p style="text-align: center;">(2)</p>

Question Number	Answer	Mark
12(c)	<p>An explanation that makes reference to four of the following points:</p> <ul style="list-style-type: none"> • Fast time to market of latest cereals • Use of ICT in market research enables manufacturer to match new cereals to market want/needs • Function / style information available for whole design team • Speed / efficiency of modelling • Modification of ideas • Improved aesthetics • Ease/speed of creating virtual products • On screen design ideas • Speed of decision making by client • Easy access to design data • Working drawings / manufacturing specifications available for whole team • Easy access to manufacturing information in company database • Manufacturing time not wasted • Efficiency of costing materials • Speed of decision making for design team / client • Allows best materials to be used • Appropriate use of database • Modelling ensures characteristics are fit for purpose • Production process are controlled better • Any other appropriate response <p style="text-align: right;">(4 x 1)</p>	(4)

Question Number	Answer	Mark
13(a)	<p>A explanation that makes reference to four of the following points to a maximum of four marks:</p> <p>On product cost up to a maximum of three marks</p> <ul style="list-style-type: none"> • Product costs are lower • PLCs controlling processes ensure scrap is not produced • Less manual labour required which is costly • Product cost would be higher if the demand for the particular type of cereal is not high • Higher maintenance costs could lead to higher product costs • Any other appropriate response <p>On introduction of new product designs up to a maximum of three marks</p> <ul style="list-style-type: none"> • Sometimes changing the automation will be lengthy • In some cases automation can be arranged to give flexible outputs from a production system • New designs / products may not always lend themselves to automation as well as old designs / products • Any other appropriate response <p style="text-align: right;">(4 x 1)</p>	(4)

<p>13(b)</p>	<p>An evaluation that makes reference to four of the following points to a maximum of four marks:</p> <p>On the work force up to a maximum of three marks</p> <ul style="list-style-type: none"> • Less jobs • Change in skills • Less employment for unskilled • Change in size • Retraining often required • Job insecurity • Different skills needed • Change in work patterns • Increased travel to work / centralisation • Working pattern / 24/7 operation • Any other appropriate response <p>On the working environment up to a maximum of three marks</p> <ul style="list-style-type: none"> • Safer • Cleaner • Quieter • Healthier • Noise pollution • Any other appropriate response <p style="text-align: right;">(4 x 1)</p>	<p style="text-align: center;">(4)</p>
Total Marks for section B		55
Total marks for paper		100

Section A

Question Number	Answer	Mark
1(a)	<ul style="list-style-type: none"> • Chocolate cheesecake • Pineapple juice <p><i>If three boxes ticked max marks = 1 mark. If 4 boxes or more ticked no marks.</i></p> <p style="text-align: right;">(2 x 1)</p>	(2)

Question Number	Answer	Mark
1(b)	<ul style="list-style-type: none"> • Washing powder • Bakers yeast <p><i>If three boxes ticked max marks = 1 mark. If 4 boxes or more ticked no marks.</i></p> <p style="text-align: right;">(2 x 1)</p>	(2)

Question Number	Answer	Mark
2(a)	<ul style="list-style-type: none"> • Biscuit cutter (accept any answer that makes reference to a specific cutter or application) <p>e.g</p> <p>Scone cutter or dough cutter Pastry cutter Pie lid cutter Pasty cutter Cutter e.g round, circle, shape</p> <p>Do not accept shaper or rounder <i>Accept any recognisable spelling (phonetic) of the answers above.</i></p> <p style="text-align: right;">(1 x 1)</p>	(1)
	<ul style="list-style-type: none"> • Egg glazing brush (accept any answer that makes reference to a specific glazing/wash brush) <p>e.g</p> <p>Egg wash brush + Egg brush Glazing brush + Yolk Brush Wash brush + Pastry Brush</p> <p>Do not accept 'brush' <i>Accept any recognisable spelling (phonetic) of the answers above.</i></p> <p style="text-align: right;">(1 x 1)</p>	(1)

Question Number	Answer	Mark
2(b)	<p>An answer that makes reference to two of the following points:</p> <ul style="list-style-type: none"> • Weighs ingredients accurately/correctly • Check weighing products/materials • Consistency of weighing ingredients/products etc • Controlling usage of ingredients (costs) • Product consistency <p>e.g Used to weigh ingredients correctly (1) helping to make the products more consistent (1)</p> <p style="text-align: right;">(2 x 1)</p>	(2)
	<p>An answer that makes reference to two of the following points:</p> <ul style="list-style-type: none"> • Used to roll out pastry, biscuit mixture, scone mixture etc • Ensures products are the same thickness • Makes a smooth surface • Helps with product consistency • To wrap sheeted pastry around to move it • The layering of puff pastry • Makes it easier to cut <p>e.g Rolls out pastry (1) by hand to the correct thickness (1)</p> <p style="text-align: right;">(2 x 1)</p>	(2)

Question Number	Answer	Mark														
3	<p data-bbox="395 293 1150 394"><i>No mark awarded where 2 or more lines are drawn from a term. Lines do not have to be straight but term and key area must be clearly linked.</i></p> <div data-bbox="395 427 1166 1435"> <table border="0"> <thead> <tr> <th data-bbox="395 427 794 461">Term</th> <th data-bbox="900 427 1027 461">Key Area</th> </tr> </thead> <tbody> <tr> <td data-bbox="395 472 639 618">Continuous operation</td> <td data-bbox="799 472 1166 685">Information & Communications Technology (ICT)</td> </tr> <tr> <td data-bbox="395 663 639 786">Computer-aided design (CAD)</td> <td data-bbox="799 472 1166 685">Information & Communications Technology (ICT)</td> </tr> <tr> <td data-bbox="395 831 639 920">Databases</td> <td data-bbox="799 472 1166 685">Information & Communications Technology (ICT)</td> </tr> <tr> <td data-bbox="395 999 639 1077">Chemical Aeriators</td> <td data-bbox="847 853 1134 999">Control technology</td> </tr> <tr> <td data-bbox="395 1167 639 1256">Automation</td> <td data-bbox="847 853 1134 999">Control technology</td> </tr> <tr> <td data-bbox="395 1335 639 1424">Antioxidants</td> <td data-bbox="863 1200 1150 1346">Modern materials</td> </tr> </tbody> </table> </div> <p data-bbox="1078 1480 1158 1514">(6 x 1)</p>	Term	Key Area	Continuous operation	Information & Communications Technology (ICT)	Computer-aided design (CAD)	Information & Communications Technology (ICT)	Databases	Information & Communications Technology (ICT)	Chemical Aeriators	Control technology	Automation	Control technology	Antioxidants	Modern materials	(6)
Term	Key Area															
Continuous operation	Information & Communications Technology (ICT)															
Computer-aided design (CAD)	Information & Communications Technology (ICT)															
Databases	Information & Communications Technology (ICT)															
Chemical Aeriators	Control technology															
Automation	Control technology															
Antioxidants	Modern materials															

Question Number	Answer	Mark
4(a)(i)	<p>Appropriate product such as;</p> <ul style="list-style-type: none"> • bread • cakes • chilled desserts • sausages • chilled ready meals • carbonated drinks • flavoured milks • ice cream • fruit pies • Materials/ eg, flavourings, cream, additives <p><i>Accept brand name of a specific product.</i></p> <p><i>This list is not exhaustive; accept any sector product that contains modern materials, utilises process control and communications technology.</i></p> <p style="text-align: right;">(1 x 1)</p>	(1)

Question Number	Answer	Mark
4(a)(ii)	<p>Appropriate explanation of what the product does, may include reference to features and function</p> <p>Eg Bread</p> <p>(i) Provides a base for the manufacture of sandwiches (1) which can be eaten by customers to provide energy (1).</p> <p>(ii) Can be used to make bread crumbs (1) to coat chicken before cooking (1).</p> <p>(iii) When cut into cubes can be made into croutons (1) to be used as an addition to soup (1)</p> <p>Cakes</p> <p>(i) Eaten by customers to satisfy hunger (1) and to provide an energy source (1).</p> <p>(ii) Can be used as base for desserts such a strawberry gateaux (1) to be used as part of a buffet (1)</p> <p>Materials/ ingredient related</p> <p><i>If product given in 4(a)(i) is not from this sector but is from the biological or chemical manufacturing sector then allow follow through up to one mark.</i></p> <p><i>No answer to 4(a)(i) no marks for 4(a)(ii)</i></p> <p style="text-align: right;">(2 x 1)</p>	(2)

Question Number	Answer	Mark
4(b)(i)	<ul style="list-style-type: none"> • design (1) marketing (1) production planning (1) materials - supply and control (1) processing/production (1) assembly/finishing (1) packaging/dispatch (1) <p><i>If product given in 4(a)(i) is not from this sector but is from the biological or chemical sector then allow follow through.</i></p> <p><i>No answer to 4(a)(i) no marks for 4(b)(i)</i></p> <p><i>Accept a process that is within any of the stages (e.g using CAD, or using CAM) or (e.g. handling customer information) or (e.g. controlling packaging processes) must be appropriate to the product stated in 4(a)(i)</i></p> <p style="text-align: right;">(1 x 1)</p>	(1)

Question Number	Answer	Mark
4(b)(ii)	<p>One mark for identifying advantage One mark for why</p> <p>Appropriate advantage to the manufacturer e.g.</p> <p>Design, marketing, production planning, materials - supply and control, processing/production, assembly/finishing, packaging/dispatch</p> <p>design</p> <ul style="list-style-type: none"> • better designs (1) - can link other information into the process (1), or best designs can be maximised by simulation (1) • faster (1) - many CAD features such as copy, array can be used (1) or if mistakes made they can be quickly rectified (1) <p>marketing</p> <ul style="list-style-type: none"> • accurate information (1) - less mistakes made in capturing data(1) • better/accessible knowledge base (1) - easy data entry/data analysed easy (1) <p>production planning</p> <ul style="list-style-type: none"> • speed (1) - faster than human application (1) <p>materials - supply and control</p> <ul style="list-style-type: none"> • buy best available materials (1) - use of internet (1) • waste control (1) - by monitoring processes and quality control of processes (1) <p>processing/production</p> <p>Answer could relate to the application of CAM and control technology such as:-</p> <ul style="list-style-type: none"> • energy conservation (1) - by control of energy into process (1) • waste control (1) - by monitoring processes and quality control of processes(1) • competitiveness (1) - faster rates of production/application of CAM techniques (1) • product consistency (1) - by control of processes (1) • cost control (1) - by less waste/faulty products (1) • efficiency (1) - by less waste/faulty products (1) • speed (1) - faster than human application (1) 	

	<p>assembly/finishing Answer could relate to the application of CAM and control technology such as:-</p> <ul style="list-style-type: none"> • energy conservation (1) - by control of energy into process (1) • waste control (1) - by monitoring processes and quality control of processes(1) • product consistency (1) - by control of processes (1) • cost control (1) - by less waste/faulty products (1) • efficiency (1) - by less waste/faulty products (1) • speed (1) - faster than human application (1) <p>packaging/dispatch Answer could relate to the application of CAM and control technology such as:-</p> <ul style="list-style-type: none"> • packaging consistency (1) - by control of processes (1) • cost control (1) - by less waste/faulty products (1) • efficiency (1) - by less waste/faulty products (1) • speed (1) - faster than human application (1) • energy conservation (1) - by control of energy into process (1) • waste control (1) - by monitoring processes and quality control of processes (1) <p><i>Low response (1) or two low responses (2) or detailed response (2)</i> <i>If the answer in part 4(b)(i) is not a manufacturing stage allow follow through up to 2 marks.</i></p> <p><i>No answer to 4(b)(i) no marks for 4(b)(ii)</i></p> <p style="text-align: right;">(1 x 1)+(1 x 1)</p>	(2)
--	---	-----

Question Number	Answer	Mark
4(c)(i)	<ul style="list-style-type: none"> • Emulsifier • Stabiliser • Chemical aerator • Preservative • Mould inhibitor • Antioxidant • Modified starch • Enzymes • Milk powder • Whey powder • Maize starch • Yeast • Other appropriate modern material - a material currently used for the given application <p><i>Accept brand name of a specific modern material</i></p> <p><i>If product given in 4(a)(i) is not from this sector but is from the biological and chemical manufacturing sector then allow follow through.</i></p> <p><i>No answer to 4(a)(i) no marks for 4(c)(i)</i></p> <p style="text-align: right;">(1 x 1)</p>	(1)

Question Number	Answer	Mark
4(c)(ii)	<p>One mark for identifying improvement One mark for how eg.</p> <p>Emulsifier</p> <ul style="list-style-type: none"> • allows liquids and oils to mix together (1) making cake mixtures lighter(1) <p>Stabiliser</p> <ul style="list-style-type: none"> • stops mixtures separating (1) making a better texture possible(1) <p>Chemical aerator</p> <ul style="list-style-type: none"> • better appearance (1) by making the product bigger(1) <p>Preservative</p> <ul style="list-style-type: none"> • extends the life-time of product (1) allows the addition of other ingredients which would normally reduce shelf life (1) • References to taste and flavour <p>Any other appropriate answers</p> <p><i>If answer in part 4(a)(i) is inappropriate but the material given in 4(c)(i) is appropriate allow follow through up to 2 marks. If no answer is given in part 4(a)(i) but the answer to part (c)(ii) relates to the material stated in part 4(c)(i) allow follow through up to 1 mark. If no answer or incorrect given in part (c)(i) no marks awarded for 4(c)(ii).</i></p> <p style="text-align: right;">(1 x 1)+(1 x 1)</p>	(2)

Question Number	Answer	Mark
5(a)	<p>One mark for identifying the benefit One mark for how</p> <ul style="list-style-type: none"> • reduced ordering times (1) - automatic monitoring (1) • improve quality / accuracy (1) - control of processes (1) • reduced wastage (1) - optimise production methods • improved efficiency (1) - faster / quicker throughput (1) • better process control (1) - in process monitoring (1) • reduced labour (1) - automated processes (1) • lower costs (1) - reduced wastage/faster/continuous production (1) • safer processes (1) - less manual input <p><i>Do not accept easier or faster/quicker without explanation.</i></p> <p><i>Low response (1) or two low responses (2) or detailed response (2), for each of 3 benefits</i></p> <p style="text-align: right;">(2 x 1) + (2 x 1) + (2 x 1)</p>	(6)

Question Number	Answer	Mark
5(b)	<p>One mark for identifying the reason One mark for how</p> <ul style="list-style-type: none"> • more consistent products (1) manufactured more accurately (1) • lower purchase price (1) faster production rates (1) • shorter order times (1) flexible methods used/variation in applied methods of production/faster production rates (1) • better quality/accurate product (1) processes controlled better/closer tolerances achieved (1) • customer satisfaction (1) better quality products produced (1) • consistent product (1) processes controlled better/closer tolerances achieved (1) • product guarantee (1) manufacturer has confidence in products produced/more reliable methods used (1) <p><i>Low response (1) or detailed statement (2) or two low responses (2)</i></p> <p style="text-align: right;">(1 x 1)+(1 x 1)</p>	(2)

Question Number	Answer	Mark
6(a)(i)	<p><i>Mark allocation 1 for a relevant type</i></p> <ul style="list-style-type: none"> • Mobile phone / infrared / bluetooth • Email / messaging • Internet / wireless / Wi-fi • Video conferencing • Electronic point of sale (EPOS) • EDI • ISDN • Texting • Phone • Walkie talkie • Fax <p><i>Do not accept: TV, CAD, radio, computer / laptop / database</i></p> <p style="text-align: right;">(1 x 1)</p>	(1)

Question Number	Answer	Mark
6(a)(ii)	<p>One mark for identifying the benefit One mark for how</p> <ul style="list-style-type: none"> • Mobile phone - can talk to supplier when needed (1) flexibility / roaming location (1) • Email - can send or receive instructions that are accurate/can get or send written confirmation of instructions (1) immediate permanent record (1) • Internet - can order and check stock immediately/in real time (1) immediate vast access to information (1) • Video conferencing -no travel expenses / less time wasted in travelling (1) but has face to face contact (1) • Electronic point of sale (EPOS) - faster / more accurate control of stock (1) automatic reading of bar codes (1) • EDI - immediate transfer of information / no hard copies needed / less storage space (1) by use of secure on-line facilities (1) • ISDN - more data transferred in parallel (1) faster response rate with supplier through use of technology (1) • Texting - can refer back to what message was given (1) stored record of transaction (1) • Phone - can clarify and confirm without having to re-visit the discussion later (1) immediate two way conversation (1) • Walkie talkie - can clarify and confirm without having to re-visit the discussion later (1) immediate two way conversation / flexibility / roaming location / cost (1) • Fax - can refer back to what message was given (1) stored record of transaction (1) <p>Other benefits may be seen in the light of: Speed, accuracy, JIT, information retrieval, meets consumer demands, quicker, increased sales, reduced stock levels, reduced running costs, reduced lead times, calculation of sales, stock taking quicker/easier, storage space reduced or any other appropriate reason</p> <p><i>Answer must relate to technology given in 6(a)(i) plus the manufacturer</i> <i>If part (a)i not answered no mark awarded.</i> <i>Do not accept: TV, CAD, radio, computer / laptop / database</i></p> <p style="text-align: right;">(1 x 1)+(1 x 1)</p>	(2)

Question Number	Answer	Mark
6(b)(i)	<p>One mark for identifying the way One mark for how</p> <ul style="list-style-type: none"> • Email can send or receive attachments (1) such as databases or spreadsheets (1) • Internet use in real time (1) can transfer sales information immediate by data entry (1) • Automated retailer use of electronic point of sale (EPOS) (1) can transfer sales data by automatic reading of bar codes (1) • Retailers can use EDI (1) for immediate transfer of sales information by use of secure on-line facilities (1) • Fax can be used to show highlight sales figures only without detail (1) by typing into the messaging system (1) <p><i>Detailed statement required for 2, two low responses (1)</i></p> <p style="text-align: right;">(1 x 1)+(1 x 1)</p>	(2)

Question Number	Answer	Mark
6(b)(ii)	<p>One mark for each point made such as:</p> <p>Email</p> <ul style="list-style-type: none"> • distributor will have permanent record • can allow manufacturer to amend record sent • sends accurate information to respond to • can export information from own systems • limited ICT skills required • low cost <p>Internet</p> <ul style="list-style-type: none"> • doesn't need manual input • information given by the distributor is up to date • can use the internet information to plan marketing campaigns • online ordering • low cost <p>Distributors can use EDI</p> <ul style="list-style-type: none"> • doesn't need manual input • information given by the distributor is up to date • immediate response to sales • more responsive to stock movement • low cost <p>Fax</p> <ul style="list-style-type: none"> • does not give away all sales details to manufacturer • low cost • immediate hard copy • better medium for authorisation • limited ICT skills required <p><i>Do not accept any answers that suggest communications technology is free of charge or is no cost</i></p> <p><i>1 x 1 mark low response, 3 x 1 mark 3 low responses or up to 3 for detailed response</i></p> <p style="text-align: right;">(3 x 1)</p>	(3)

Question Number	Answer	Mark
7(a)	<p>One mark for each point made up to 2 marks such as:</p> <ul style="list-style-type: none"> • safer for operators/workers • can handle hazardous processes • does not suffer from fatigue • does not make errors relative to safety aspects • more efficient/does not tire • less waste • once set up correctly will continue to produce to a given standard • Can detect production/ process problems • Can promote multiskilling <p><i>Any other appropriate response.</i> <i>Low response (1) or detailed statement (2)</i></p> <p style="text-align: right;">(1 x 1)+(1 x 1)</p>	(2)

Question Number	Answer	Mark
7(b)	<p>One mark for each point made up to 2 marks such as:</p> <ul style="list-style-type: none"> • high set up costs • may have high running costs • may have high maintenance requirements • may not have flexibility in product range • may need close computer control to avoid mal-function <p><i>Any other appropriate response.</i> <i>Low responses (1) or detailed statement (2)</i></p> <p>Do not accept an answer relating to less employees</p> <p style="text-align: right;">(1 x 1)+(1 x 1)</p>	(2)
Total marks for section A		45

Section B

Question Number	Answer	Mark
8(a)	<p>Any answer that makes reference to three of the following points:</p> <ul style="list-style-type: none"> • Fibre • Flavour • Taste • Texture • Viscosity • Colour • Nutrition • Encourage consumers to buy • Healthy eating • Vitamin C • Natural • Appearance • Variety <p style="text-align: right;">(3 x 1)</p>	(3)

Question Number	Answer	Mark
8(b)	<p>Any answer that makes reference to three of the following points:</p> <ul style="list-style-type: none"> • Provides protein • Provides energy • Provides some carbohydrate • Source of calcium • Source of calories • Source of sugar • Source of vitamins (A & C) • Flavour • Taste • Liquid • Viscosity • Bulking agent • Food source for yoghurt bacteria • Texture • Nutrients • Fermentation (Food Source) • Healthy <p style="text-align: right;">(3 x 1)</p>	(3)

Question Number	Answer	Mark
9(a)(i)	<ul style="list-style-type: none"> • Marketing • Production Planning or Planning <p style="text-align: center;">Do not accept production on its own</p> <p><i>Must be in this order</i></p> <p style="text-align: right;">(1 x 1)+(1 x 1)</p>	(2)

Question Number	Answer	Mark
9(a)(ii)	<ul style="list-style-type: none"> • Packaging and dispatch • Packaging • Stage 7 / stage seven • 7 / seven • assembly • Stage 6/ Stage 6 • 6/ Six <p><i>Accept any recognisable spelling (phonetic) of the answers above.</i></p> <p style="text-align: right;">(1 x 1)</p>	(1)

Question Number	Answer	Mark
9(b)(i)	<p>Appropriate descriptions including three of the following points:</p> <ul style="list-style-type: none"> • Creating drawings • Customers specific requirements • Creating sketches • Producing prototypes • Modifying product specification • Making samples • Appearance • Taste • Developing recipes • Developing product specifications • Developing process specifications • Liaising with marketing department • Liaising with production department • Liaising with customers • Calculating initial costing data • Calculating nutritional values • Providing allergy information • Providing information for advertising • Setting raw material specifications • Setting packaging specifications • Packaging information required • Supporting plant trials <p>Any other appropriate response</p> <p>Example answers;</p> <p>(i)The stage where the customers brief (1) is translated into a recipe (1) before samples are made (1). (ii)The stage where the marketing department discuss new product requirements(1) with the development department who then make prototype products(1) with an outline costing(1)</p> <p>Up to 3 marks</p> <p><i>1 x 1 mark low response, 3 x 1 mark 3 low responses or up to 3 for detailed response</i></p> <p style="text-align: right;">(3x1)</p>	(3)

Question Number	Answer	Mark
9(b)(ii)	<p>Appropriate descriptions including three of the following points:</p> <ul style="list-style-type: none"> • Assembly of raw materials/ingredients • Assembling staff • Assembly of equipment • Weighing raw materials/ingredients • Measuring raw materials and ingredients • Setting up plant and equipment • Manufacturing to specification • Mixing ingredients • Preparing cultures • Pre treatment of milk • Homogenization of the milk • Heat treatment of milk • Incubation • Inoculation with starter cultures • Fermentation • Cooling • Pasteurization • Maintaining hygiene • Achieving throughputs • Achieving quality standards • Achieving food safety standard • Maintaining records • Training staff • Monitoring production costs • Controlling production costs <p>Any other appropriate response</p> <p>Example answers;</p> <p>(i)The stage where the milk is homogenized (1) prior to the addition of the starter culture (1) so that fermentation (1) can take place and yoghurt is correct.</p> <p>(ii) The stage where all the plant and equipment is set up(1) and the ingredients assembled (1) to make the yoghurt, high standards of hygiene (1) are essential when manufacturing the yoghurt</p> <p><i>1 x 1 mark low response, 3 x 1 mark 3 low responses or up to 3 for detailed response</i></p> <p style="text-align: right;">(3 x 1)</p>	(3)

Question Number	Answer	Mark
10(a)(i)	<p>Specific materials to make the pots;</p> <ul style="list-style-type: none"> • Polystyrene (PS) • Plastic/ blow moulded plastic/ vacuum formed plastic • Food grade plastic • Pvc/ Polyvynlchloride • Wax coated card <p><i>Accept any recognisable spelling (phonetic) of the answers above.</i></p> <p style="text-align: right;">(1 x 1)</p>	(1)

Question Number	Answer	Mark
10(a)(ii)	<p>Specific materials to make the sealed on lid</p> <ul style="list-style-type: none"> • Foil/ Alluminium foil/ tin foil • Laminated foil • Coated foil • Heat sealable foil • Printed foil • Coated paper • Coated greaseproof paper <p><i>Accept any recognisable spelling (phonetic) of the answers above.</i></p> <p style="text-align: right;">(1 x 1)</p>	(1)

Question Number	Answer	Mark
10(b)(i)	<p>Any three of the following:</p> <ul style="list-style-type: none"> • Yoghurt products • Weighing ingredients • Collecting/ assembling ingredients • Measuring ingredients • Adding ingredients • Mixing ingredients • Homogenizing milk • Inoculation with culture • Incubation • Heat treatment • Temperature control • Pasteurisation of milk • Cooling • Fruit addition • Refrigeration • Freezing • Packaging • Brown moulded pots • Foil cutting • Coding etc <p>Any other appropriate production process eg linked to batch/mass or continuous production methods</p> <p>Do not accept filling and /or sealing the pots <i>1 mark per response up to 2</i></p> <p><i>Accept any recognisable spelling (phonetic) of the answers above.</i></p> <p style="text-align: right;">(3 x 1)</p>	(3)

Question Number	Answer	Mark
10(b)(ii)	<p>Appropriate explanation including two of the following points:</p> <ul style="list-style-type: none"> • To allow the cultures/bacteria to convert milk to yoghurt eg lactobacillus bulgaricus /streptococcus thermophilus • To create acid taste • To reduce the pH • To coagulate/set the yoghurt/thicken/texture • To set the yoghurt • Increase shelf life <p>any similar answer</p> <p>Example answer;</p> <p>(i)The fermentation stage of manufacture allows the good bacteria to work (1) making the yoghurt coagulate (1).</p> <p>(ii) During the fermentation stage the Ph reduces (1) and the yoghurt starts to set (1).</p> <p><i>1 x 1 mark low response, or up to 3 for detailed response</i></p> <p style="text-align: right;">(2 x 1)</p>	(2)

Question Number	Answer	Mark
10(c)	<p>An explanation that makes reference to three of the following points:</p> <ul style="list-style-type: none"> • Improved texture • Taste changes • More flavours • Better functionality • More variation of products • Shelf life improvements • Viscosity control • Product stability • Expanding markets (export, restaurants, catering) • Easier manufacturing • Health related e.g. Low fat, low sugar • Any other appropriate answer <p><i>Up to 3 x 1 mark low responses or up to 3 marks for a detailed response</i></p> <p style="text-align: right;">(3 x 1)</p>	(3)

Question Number	Answer	Mark
11(a)(i)	<p>One application such as:</p> <ul style="list-style-type: none"> • check physical damage • contamination checks • weight checks • volume checks • flavour/taste checks • viscosity checks • colour checks • temperature checks • time checks • micro -organism checks • acidity checks • Packaging checks, e.g. seals, codings, safe edges, printing quality, temps • any other appropriate answer <p><i>Must be within production stages</i></p> <p style="text-align: right;">(1 x 1)</p>	(1)

Question Number	Answer	Mark
11(a)(ii)	<p>Description of how such as:</p> <ul style="list-style-type: none"> • check physical damage - by visual inspection (1) and checking against drawing/specification (1) • contamination checks - by visual inspection (1) metal detection (1) or x ray (1) • weight checks - use electronic scales(1) or in line weigh check conveyors (1) • volume checks - use of fixed volume cups (1) and specific volume to weight checks(1) • flavour/taste checks - use of individual trained quality taster (1) and measuring acidity and alkalinity with a meter (1) • viscosity checks - use of flow rate gauges (1) and inspection equipment (1) • colour checks - visual checks against a colour chart (1) use of computer calibrated equipment(1) • temperature checks- use of manual hand held thermometers(1) and in- line continuous temperature checks which make automatic adjustments (1) • time checks- use of stop watches (1) in -line continuous time recording (1) • micro- organisms checks- use swabs (1) and laboratory facilities to measure bacteria (1) • Ph checks- use indicator papers (1) as quick check and Ph meters for precise measurements (1) <p><i>Allow follow through up to 1 mark and if no answer in part Q11 (a)i up to 1 mark for a correct answer.</i></p> <p style="text-align: right;">(2 x 1)</p>	(2)

Question Number	Answer	Mark
11(a)(iii)	<p>An explanation that makes reference to three of the following points:</p> <ul style="list-style-type: none"> • safer product to eat • confidence in product reliability • reduced anxiety when eating • consistent product • quality • ensures standards are met • longer useable life • don't have to buy as often • product reliability • freshness • confidence in the company • lower prices • correct information • any other appropriate response <p><i>Must relate to the consumer</i></p> <p style="text-align: right;">(3 x 1)</p>	(3)

Question Number	Answer	Mark
11(b)(i)	<p>One mark for stating the use of computer control</p> <ul style="list-style-type: none"> • CAD • Packaging, e.g making/ filling pots, stacking lids, labels • Controlling raw material/ingredient flow • Controlling temperatures • Packing/ palletising • Controlling times • Controlling viscosity/ flow • Product counting • Controlling output • CAM • Robot / conveyor system • CIM • CIE • Programmable logic controllers PLCs <p>Must be withing production and packing</p> <p style="text-align: right;">(1 x 1)</p>	(1)

Question Number	Answer	Mark
11(b)(ii)	<p>Two marks for the description eg ;</p> <ul style="list-style-type: none"> • Downloads specifications (1) - to plant and equipment (1) • Controls the flow of ingredients to the plant(1) by using computerised transfer systems (1) • Computer setting of times / temps/viscosity/ (1) automatic adjustments made to stay within specification (1) • Computer controls the positioning of the robot (1) to carry out a difficult manoeuvre (1) <p><i>1 x 1 mark for low response or 2 x 1 marks for detailed response</i> <i>If no computer control is stated or inappropriate answer is given allow follow through up to 1 mark for an appropriate description.</i></p> <p style="text-align: right;">(2 x 1)</p>	(2)

Question Number	Answer	Mark
11(c)	<p>An explanation that makes reference to three of the following points:</p> <ul style="list-style-type: none"> • makes sure current specification is always used during manufacture • safer production methods • product reliability / consistent product • ensures standards are met • lower costs / control of costs / more profit • less scrap / waste / more efficient • avoids faulty product being packaged • early detection of problems • increased sales • user confidence / less returns • reduced waste • control of manufacturing process • monitoring standards testing • no breaking parts • monitoring products proceed specification • any other appropriate response <p><i>If no answer or inappropriate answer is given in part 11(b)i allow follow through up to 1 mark maximum for appropriate benefits.</i></p> <p style="text-align: right;">(3 x 1)</p>	(3)

Question Number	Answer	Mark
12(a)(i)	<p>Any two of the following:</p> <ul style="list-style-type: none"> Analyse market research data in database Assists with pricing products Cost the resource requirements for pots of virtually fat free fruit yoghurt in spreadsheet Plan marketing campaign using DTP software Use of internet/website for marketing Or similar <p><i>1 mark per response up to 2</i></p>	(2)
	(2 x 1)	(2)

Question Number	Answer	Mark
12(a)(ii)	<p>One mark for identifying the use One mark for how:</p> <ul style="list-style-type: none"> Development of labelling (1) and / by electronic application protocol (1) Electronic monitoring (1) of some packaging processes (1) Use of bar codes (1) to monitor packaging / dispatch of pots of virtually fat free fruit yoghurt(1) Use of software (1) to record, log output of pots of virtually fat free fruit yoghurt (1) Any other appropriate response 	(2)
	(1 x 1)+(1 x 1)	(2)

Question Number	Answer	Mark
12(b)	<p>One mark for identifying the benefit One mark for how</p> <ul style="list-style-type: none"> Establishes a market database (1) shared with the manufacturer (1) Has accurate costing information (1) shared with the manufacturer (1) / that can be manipulated easily (1) Gives retailers opportunity to match the market needs (1) with production of pots of virtually fat free fruit yoghurt (1) Any other appropriate response 	(2)
	(1 x 1)+(1 x 1)	(2)

Question Number	Answer	Mark
12(c)	<p>An explanation that makes reference to four of the following points:</p> <ul style="list-style-type: none"> • Improves aesthetics • Improved packaging design • Fast time to market of latest type/flavour pots of virtually fat free fruit yoghurt • Use of ICT in market research enables manufacturer to match the pots of virtually fat free fruit yoghurt to market needs • Function / style information available for whole design team • Speed / efficiency of modelling • Modification of ideas • Ease/speed of creating virtual products • Modelling ensures characteristics are fit for purpose • On screen design ideas • Speed of decision making by client • Easy access to design data • Working drawings / manufacturing specifications available for whole team • Easy access to manufacturing information in company database • Manufacturing time not wasted • Production process are controlled better • Efficiency of costing materials • Speed of decision making for design team / client • Allows best materials to be used • Any other appropriate response <p style="text-align: right;">(4 x 1)</p>	(4)

Question Number	Answer	Mark
13(a)	<p>A explanation that makes reference to four of the following points to a maximum of four marks:</p> <p>On product cost up to a maximum of three marks</p> <ul style="list-style-type: none"> • Product costs are lower • PLCs controlling processes ensure scrap/waste is not produced • Less manual labour required which is costly • Product cost would be higher if the demand for the pots of virtually fat free fruit yoghurt is not high • Higher maintenance could lead to higher product costs • Any other appropriate response <p>On introduction of new product designs up to a maximum of three marks</p> <ul style="list-style-type: none"> • Sometimes changing the automation will be lengthy • In some cases automation can be arranged to give flexible outputs from a production system • New designs / products may not always lend themselves to automation as well as old designs / products • Any other appropriate response <p style="text-align: right;">(4 x 1)</p>	(4)

Question Number	Answer	Mark
13(b)	<p>An evaluation that makes reference to four of the following points to a maximum of four marks:</p> <p>On the work force up to a maximum of three marks</p> <ul style="list-style-type: none"> • Less jobs • Change in skills • Less employment for unskilled • Change in size • Retraining often required • Different skills needed • Change in work patterns • Increased travel to work / centralisation • Working pattern / 24/7 operation • Any other appropriate response <p>On the working environment up to a maximum of three marks</p> <ul style="list-style-type: none"> • Safer • Cleaner • Quieter • Healthier • Any other appropriate response <p style="text-align: right;">(4 x 1)</p>	(4)
Total Marks for section B		(55)
Total marks for paper		(100)

Section A

Question Number	Answer	Mark
1(a)	<ul style="list-style-type: none"> Laptop case Roman blind <p><i>If three boxes ticked max marks = 1 mark. If 4 boxes or more ticked no marks.</i></p> <p style="text-align: right;">(2 x 1)</p>	(2)

Question Number	Answer	Mark
1(b)	<ul style="list-style-type: none"> High visibility vest Driving gloves <p><i>If three boxes ticked max marks = 1 mark. If 4 boxes or more ticked no marks.</i></p> <p style="text-align: right;">(2 x 1)</p>	(2)

Question Number	Answer	Mark
2(a)	<ul style="list-style-type: none"> Industrial steam iron (accept any answer that makes reference to a iron) e.g Industrial iron Steam iron Pressing station Iron Steam generator <p>Do not accept press <i>Accept any recognisable spelling (phonetic) of the answers above.</i></p> <p style="text-align: right;">(1 x 1)</p>	(1)
	<ul style="list-style-type: none"> Spool case (accept any answer that makes reference to a spool case)eg. Bobbin case Thread case <p>Do not accept 'case' Do not accept 'spool' on its own. <i>Accept any recognisable spelling (phonetic) of the answers above.</i></p> <p style="text-align: right;">(1 x 1)</p>	(1)

Question Number	Answer	Mark
2(b)	<p>An answer that makes reference to two of the following points:</p> <ul style="list-style-type: none"> • Unpicks stitches • Unpicks thread • Unpicks seams • Can undo mistakes in stitching <p>e.g Used to unpick stitches(1) when you've made a mistake in sewing (1)</p> <p style="text-align: right;">(2 x 1)</p>	(2)
	<p>An answer that makes reference to two of the following points:</p> <ul style="list-style-type: none"> • To hold fabric tight/taught/secure • To keep stitch tension even • Screw holds hoop and fabric • To hold fabric when doing hand/ machine embroidery • To keep stitching consistent <p>e.g An embroidery hoop holds fabric (1) tight to keep stitching even (1)</p> <p style="text-align: right;">(2 x 1)</p>	(2)

Question Number	Answer	Mark														
3	<p data-bbox="395 293 1150 394"><i>No mark awarded where 2 or more lines are drawn from a term. Lines do not have to be straight but term and key area must be clearly linked.</i></p> <div data-bbox="395 427 1166 1435"> <table border="0"> <thead> <tr> <th data-bbox="395 427 794 461">Term</th> <th data-bbox="900 427 1027 461">Key Area</th> </tr> </thead> <tbody> <tr> <td data-bbox="395 472 639 618">Continuous operation</td> <td data-bbox="799 472 1166 685">Information & Communications Technology (ICT)</td> </tr> <tr> <td data-bbox="395 663 639 786">Computer-aided design (CAD)</td> <td data-bbox="799 472 1166 685">Information & Communications Technology (ICT)</td> </tr> <tr> <td data-bbox="395 831 639 920">Databases</td> <td data-bbox="799 472 1166 685">Information & Communications Technology (ICT)</td> </tr> <tr> <td data-bbox="395 999 639 1088">Polymers</td> <td data-bbox="847 853 1134 1010">Control technology</td> </tr> <tr> <td data-bbox="395 1167 639 1256">Automation</td> <td data-bbox="847 853 1134 1010">Control technology</td> </tr> <tr> <td data-bbox="395 1346 639 1435">Thermo chromic dyes</td> <td data-bbox="863 1200 1150 1357">Modern materials</td> </tr> </tbody> </table> </div> <p data-bbox="1078 1480 1161 1514">(6 x 1)</p>	Term	Key Area	Continuous operation	Information & Communications Technology (ICT)	Computer-aided design (CAD)	Information & Communications Technology (ICT)	Databases	Information & Communications Technology (ICT)	Polymers	Control technology	Automation	Control technology	Thermo chromic dyes	Modern materials	(6)
Term	Key Area															
Continuous operation	Information & Communications Technology (ICT)															
Computer-aided design (CAD)	Information & Communications Technology (ICT)															
Databases	Information & Communications Technology (ICT)															
Polymers	Control technology															
Automation	Control technology															
Thermo chromic dyes	Modern materials															

Question Number	Answer	Mark
4(a)(i)	<p>Appropriate product such as e.g</p> <ul style="list-style-type: none"> • biker gloves • back pack • wallet • fire protective clothing • football shirt • weather protective jacket • high visibility vest • swimsuit • oven gloves <p><i>Accept brand name of a specific product.</i></p> <p><i>This list is not exhaustive, accept any product that contains textiles or clothing componentry or association with the sector.</i></p> <p style="text-align: right;">(1 x 1)</p>	(1)

Question Number	Answer	Mark
4(a)(ii)	<p>Appropriate explanation of what the product does, may include reference to features and function</p> <p>E.g.</p> <ul style="list-style-type: none"> • Biker gloves-To protect your hands (1) if you fall off (1) • Back pack-To carry items (1) easily on your back(1) • Wallet-Used to put in money or credit cards (1) to carry in pocket or coat (1) <p><i>If product given in 4(a)(i) is not from this sector but is from one of the other engineering manufacturing sectors then allow follow through up to one mark.</i></p> <p><i>No answer to 4(a)(i) no marks for 4(a)(ii)</i></p> <p style="text-align: right;">(2 x 1)</p>	(2)

Question Number	Answer	Mark
4(b)(i)	<ul style="list-style-type: none"> • design (1) marketing (1) production planning (1) materials - supply and control (1) processing/production (1) assembly/finishing (1) packaging/dispatch (1) <p><i>If product given in 4(a)(i) is not from this sector but is from one of the other engineering manufacturing sectors then allow follow through.</i></p> <p><i>No answer to 4(a)(i) no marks for 4(b)(i)</i></p> <p><i>Accept a process that is within any of the stages (e.g using CAD, or using CAM) or (e.g. handling customer information) or (e.g. controlling packaging processes) must be appropriate to the product stated in 4(a)(i)</i></p> <p style="text-align: right;">(1 x 1)</p>	(1)

Question Number	Answer	Mark
4(b)(ii)	<p>One mark for identifying advantage One mark for why</p> <p>Appropriate advantage to the manufacturer e.g.</p> <p>Design, marketing, production planning, materials - supply and control, processing/production, assembly/finishing, packaging/dispatch</p> <p>design</p> <ul style="list-style-type: none"> • better designs (1) - can link other information into the process (1), or best designs can be maximised by simulation (1) • faster (1) - many CAD features such as copy, array can be used (1) or if mistakes made they can be quickly rectified (1) <p>marketing</p> <ul style="list-style-type: none"> • accurate information (1) - less mistakes made in capturing data (1) • better/accessible knowledge base (1) - easy data entry/data analysed easy (1) <p>production planning</p> <ul style="list-style-type: none"> • speed (1) - faster than human application (1) <p>materials - supply and control</p> <ul style="list-style-type: none"> • buy best available materials (1) - use of internet (1) • waste control (1) - by monitoring processes and quality control of processes (1) <p>processing/production</p> <p>Answer could relate to the application of CAM and control technology such as:-</p> <ul style="list-style-type: none"> • energy conservation (1) - by control of energy into process (1) • waste control (1) - by monitoring processes and quality control of processes(1) • competitiveness (1) - faster rates of production/application of CAM techniques (1) • product consistency (1) - by control of processes (1) • cost control (1) - by less waste/faulty parts (1) • efficiency (1) - by less waste/faulty parts (1) • speed (1) - faster than human application (1) 	

	<p>assembly/finishing Answer could relate to the application of CAM and control technology such as:-</p> <ul style="list-style-type: none"> • energy conservation (1) - by control of energy into process (1) • waste control (1) - by monitoring processes and quality control of processes(1) • product consistency (1) - by control of processes (1) • cost control (1) - by less waste/faulty parts (1) • efficiency (1) - by less waste/faulty parts (1) <p>speed (1) - faster than human application (1)</p> <p>packaging/dispatch Answer could relate to the application of CAM and control technology such as:-</p> <ul style="list-style-type: none"> • packaging consistency (1) - by control of processes (1) • cost control (1) - by less waste/faulty parts (1) • efficiency (1) - by less waste/faulty parts (1) • speed (1) - faster than human application (1) • energy conservation (1) - by control of energy into process (1) • waste control (1) - by monitoring processes and quality control of processes (1) <p><i>Low response (1) or two low responses (2) or detailed response (2)</i> <i>If the answer in part 4(b)(i) is not a Manufacturing stage allow follow through up to 2 marks.</i></p> <p><i>No answer to 4(b)(i) no marks for 4(b)(ii)</i></p>	<p style="text-align: right;">(1 x 1)+(1 x 1)</p> <p style="text-align: right;">(2)</p>
--	---	--

Question Number	Answer	Mark
4(c)(i)	<ul style="list-style-type: none"> • stretch denim (with elastane/ 'lycra') • dark/ light wash denim • Teflon coated twill • Other coated fabrics • thermo chromic dyes • liquid crystal coating (eg in a reflective print) • Other appropriate modern material - a material currently used for the given application <p><i>Accept brand name of a specific material</i></p> <p><i>If product given in 4(a)(i) is not from this sector but is from one of the other engineering manufacturing sectors then allow follow through.</i></p> <p><i>No answer to 4(a)(i) no marks for 4(c)(i)</i></p> <p style="text-align: right;">(1 x 1)</p>	(1)

Question Number	Answer	Mark
4(c)(ii)	<p>One mark for identifying improvement One mark for how</p> <ul style="list-style-type: none"> • smaller size (1) - miniaturisation (1) • lower weight (1) - better strength to weight ratio (1) • better appearance (1) - smoother/brighter finishes (1) • extends the life-time of product (1) - better wear characteristics (1) • improves wear resistance (1) - harder materials/better surface finish (1) • reduces cost (1) - overall product easier/earlier machine ability (1) <p><i>If answer in part 4(a)(i) is inappropriate but the material given in 4(c)(i) is appropriate allow follow through up to 2 marks. If no answer is given in part 4(a)(i) but the answer to part 4(c)(ii) relates to the material stated in part 4(c)(i) allow follow through up to 1 mark. If no answer or incorrect answer given in part 4(c)(i) no marks awarded for 4(c)(ii).</i></p> <p style="text-align: right;">(1 x 1)+(1 x 1)</p>	(2)

Question Number	Answer	Mark
5(a)	<p>One mark for identifying the benefit One mark for how Answers must relate to manufacturer</p> <ul style="list-style-type: none"> • reduced ordering times (1) - automatic monitoring (1) • improve quality / accuracy (1) - control of processes (1) • reduced wastage (1) - optimise production methods (1) • improved efficiency (1) - faster / quicker throughput (1) • better process control (1) - in process monitoring (1) • reduced labour (1) - automated processes (1) • lower costs (1) - reduced wastage/faster/continuous production (1) • safer processes (1) - less manual input (1) <p><i>Do not accept 'easier' or 'faster' / 'quicker' without explanation.</i></p> <p><i>Low response (1) or two low responses (2) or detailed response (2), for each of 3 benefits</i></p> <p style="text-align: right;">(2 x 1) + (2 x 1) + (2 x 1)</p>	(6)

Question Number	Answer	Mark
5(b)	<p>One mark for identifying the reason One mark for how Answers must relate to consumer</p> <ul style="list-style-type: none"> • more consistent products (1) manufactured more accurately (1) • lower purchase price (1) faster production rates (1) • shorter order times (1) flexible methods used/variation in applied methods of production/faster production rates (1) • better quality/accurate product (1) processes controlled better/closer tolerances achieved (1) • customer satisfaction (1) better quality products produced (1) • consistent product (1) processes controlled better/closer tolerances achieved (1) • product guarantee (1) manufacturer has confidence in products produced/more reliable methods used (1) <p><i>Low response (1) or detailed statement (2) or two low responses (2)</i></p> <p style="text-align: right;">(1 x 1) + (1 x 1)</p>	(2)
Question Number	Answer	Mark
6(a)(i)	<p><i>Mark allocation 1mark for a relevant type</i></p> <ul style="list-style-type: none"> • Mobile phone / infrared / bluetooth • Email / messaging • Internet / wireless / Wi-fi • Video conferencing • Electronic point of sale (EPOS) • EDI • ISDN • Texting • Phone • Walkie talkie • Fax <p><i>Do not accept: TV, CAD, radio, computer / laptop / database</i></p> <p style="text-align: right;">(1 x 1)</p>	(1)

Question Number	Answer	Mark
6(a)(ii)	<p>One mark for identifying the benefit One mark for how</p> <ul style="list-style-type: none"> • Mobile phone - can talk to supplier when needed (1) flexibility / roaming location (1) • Email - can send or receive instructions that are accurate/can get or send written confirmation of instructions (1) immediate permanent record (1) • Internet - can order and check stock immediately/in real time (1) immediate vast access to information (1) • Video conferencing -no travel expenses / less time wasted in travelling (1) but has face to face contact (1) • Electronic point of sale (EPOS) - faster / more accurate control of stock (1) automatic reading of bar codes (1) • EDI - immediate transfer of information / no hard copies needed / less storage space (1) by use of secure on-line facilities (1) • ISDN - more data transferred in parallel (1) faster response rate with supplier through use of technology (1) • Texting - can refer back to what message was given (1) stored record of transaction (1) • Phone - can clarify and confirm without having to re-visit the discussion later (1) immediate two way conversation (1) • Walkie talkie - can clarify and confirm without having to re-visit the discussion later (1) immediate two way conversation / flexibility / roaming location / cost (1) • Fax - can refer back to what message was given (1) stored record of transaction (1) <p>Other benefits may be seen in the light of:</p> <p>Speed, accuracy, JIT, information retrieval, meets consumer demands, quicker, increased sales, reduced stock levels, reduced running costs, reduced lead times, calculation of sales, stock taking quicker/easier, storage space reduced or any other appropriate reason</p> <p><i>Answer must relate to technology given in 6(a)(i)</i></p> <p><i>If part 6(a)(i) is not answered or answered incorrectly, no mark awarded for 6(a)(ii).</i></p> <p style="text-align: right;">(1 x 1)+(1 x 1)</p>	(2)

Question Number	Answer	Mark
6(b)(i)	<p>One mark for identifying the way One mark for how</p> <ul style="list-style-type: none"> • Email can send or receive attachments (1) such as databases or spreadsheets (1) • Internet use in real time (1) can transfer sales information immediately by data entry (1) • Automated retailer use of electronic point of sale (EPOS) (1) can transfer sales data by automatic reading of bar codes (1) • Retailers can use EDI (1) for immediate transfer of sales information by use of secure on-line facilities (1) • Fax can be used to show highlight sales figures only without detail (1) by typing into the messaging system (1) <p><i>Detailed statement required for 2, two low responses (1)</i></p> <p style="text-align: right;">(1 x 1)+(1 x 1)</p>	(2)

Question Number	Answer	Mark
6(b)(ii)	<p>One mark for each point made such as:</p> <p>Email</p> <ul style="list-style-type: none"> • retailer will have permanent record • can allow manufacturer to amend record sent • sends accurate information to respond to • can export information from own systems • limited ICT skills required • low cost <p>Internet</p> <ul style="list-style-type: none"> • doesn't need manual input • information given by the retailer is up to date • can use the internet information to plan marketing campaigns • online ordering • low cost <p>Retailers can use EDI</p> <ul style="list-style-type: none"> • doesn't need manual input • information given by the retailer is up to date • immediate response to sales • more responsive to stock movement • low cost <p>Fax</p> <ul style="list-style-type: none"> • does not give away all sales details to manufacturer • low cost • immediate hard copy • better medium for authorisation • limited ICT skills required <p><i>Do not accept any answers that suggest communications technology is free of charge or is no cost</i></p> <p><i>1 x 1 mark low response, 3 x 1 mark 3 low responses or up to 3 for detailed response</i></p> <p>if part 6(b)(i) is not answered or answered incorrectly, but the answer to 6 (b) (ii) identifies the communications technology, allow follow through up to 2 marks.</p> <p style="text-align: right;">(3 x 1)</p>	(3)

Question Number	Answer	Mark
7(a)	<p>One mark for each point made up to 2 marks such as:</p> <ul style="list-style-type: none"> • can handle hazardous processes • safer for operators/workers • can promote multiskilling • does not suffer from fatigue • does not make errors relative to safety aspects • more efficient/does not tire • less waste • once set up correctly will continue to produce to a given standard • can detect production/ process problems <p><i>Any other appropriate response.</i> <i>Low responses (1) or detailed statement (2)</i> (1 x 1)+(1 x 1)</p>	(2)

Question Number	Answer	Mark
7(b)	<p>One mark for each point made up to 2 marks such as:</p> <ul style="list-style-type: none"> • high set up costs • may have high running costs • may have high maintenance requirements • may not have flexibility in product range • may need close computer control to avoid mal-function <p><i>Any other appropriate response.</i> <i>Low response (1) or detailed statement (2)</i> Do not accept "cost" without explanation.</p> <p>Do not accept answers relating to less employees</p> <p>(1 x 1)+(1 x 1)</p>	(2)
Total marks for section A		(45)

Section B

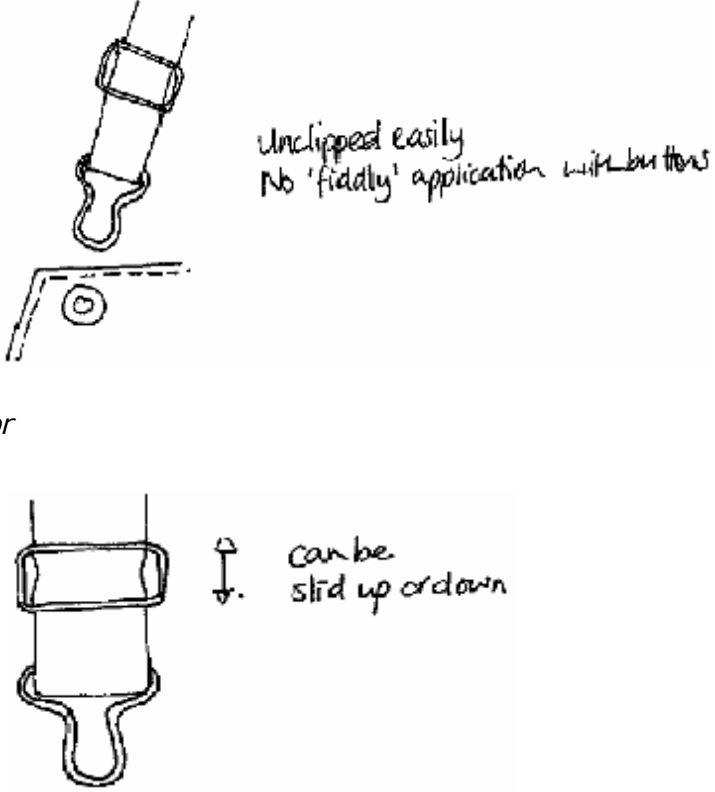
Question Number	Answer	Mark
8(a)	<p>An answer that makes reference to three of the following points:</p> <ul style="list-style-type: none"> • to fasten straps to buttons • to adjust size of straps • to adjust length of straps • easy opening • more secure than button and buttonhole <p><i>Answer must contain both notes and sketches. Max two marks if only notes or only sketches used.</i></p> <p><i>Eg.</i></p>  <p style="text-align: right;">(3 x 1)</p>	(3)

Question Number	Answer	Mark
8(b)	<p>An answer that makes reference to three of the following points:</p> <ul style="list-style-type: none"> • fastening • easy opening to undress child • decoration • provides comfort when fastened • provides secure fastening rather than a button <p><i>Answer must contain both notes and sketches. Max two marks if only notes or only sketches used.</i></p> <p><i>Eg.</i></p>  <p style="text-align: right;">(3 x 1)</p>	(3)

Question Number	Answer	Mark
9(a)(i)	<ul style="list-style-type: none"> • Marketing • Production Planning or Planning or plan <p>Do not accept production on its own</p> <p><i>Must be in this order</i></p>	<p>(1 x 1)+(1 x 1)</p> <p>(2)</p>

Question Number	Answer	Mark
9(a)(ii)	<ul style="list-style-type: none"> • Production/processing • Stage 5 / stage five • 5 / five • Assembly • Stage 6/ stage six • 6/ six <p><i>Accept any recognisable spelling (phonetic) of the answers above.</i></p>	<p>(1 x 1)</p> <p>(1)</p>

Question Number	Answer	Mark
9(b)(i)	<p>Appropriate descriptions including three of the following points:</p> <ul style="list-style-type: none"> • Fitting of parts together (sewing together of fabric pieces) • Completing the assembly or sub-assembly of the dungarees • Parts are fitted/assembled in the correct order • Where the appliqué and embroidery is done • Popper openings tested for security • Any other appropriate response <p>The stage where the dungarees are assembled (1) and the individual parts are fitted in the correct order (1). It is where the appliqué is stitched on (1) and the poppers are opened and closed (1) to check they are secure (1) Up to 3 marks</p> <p><i>1 x 1 mark low response, 3 x 1 mark 3 low responses or up to 3 for detailed response</i></p>	<p>(3 x 1)</p> <p>(3)</p>

Question Number	Answer	Mark
9(b)(ii)	<p>Appropriate descriptions including three of the following points:</p> <ul style="list-style-type: none"> • Application of protective packaging • Assembling orders • Application of codes, dates, tech info • Picking orders • Assembling loads • Packing into outer boxes • Making records • Application of labels to boxes • Sending to client • Final visual checks • Collation of multiple items • Any other appropriate response <p>The stage where the finished children’s dungarees have any labels added (1), and are prepared for shipment (1) by the use of any protective materials (1) such as plastic packaging (1). The packaged dungarees are loaded onto the preferred method of dispatch and carrier (1) to be sent to the customer or retailer (1). Up to 3 marks</p> <p><i>1 x 1 mark low response, 3 x 1 mark 3 low responses or up to 3 for detailed response</i></p> <p style="text-align: right;">(3 x 1)</p>	(3)

Question Number	Answer	Mark
10(a)(i)	<p>Specific materials to make the appliqué</p> <ul style="list-style-type: none"> • Felt • Cotton • Fleece • Polyester • Nylon • Reversed denim • Denim • Cotton/Polyester • Teflon coated fabric • Single jersey <p><i>Accept any recognisable spelling (phonetic) of the answers above.</i></p> <p style="text-align: right;">(1 x 1)</p>	(1)

Question Number	Answer	Mark
10(a)(ii)	<p>Specific materials to make the pocket lining</p> <ul style="list-style-type: none"> • Woven cotton/polyester • Single jersey • Nylon • Self fabric/denim • Cotton • Denim • Polyester <p><i>Accept any recognisable spelling (phonetic) of the answers above.</i></p> <p style="text-align: right;">(1 x 1)</p>	(1)

Question Number	Answer	Mark
10(a)(iii)	<p>Specific materials to make the trousers</p> <ul style="list-style-type: none"> • Denim • Cotton drill/twill • Woven Cotton/polyester • Teflon coated cotton • Linen • Cotton • Polyester • Teflon coated product <p><i>Accept any recognisable spelling (phonetic) of the answers above.</i></p> <p style="text-align: right;">(1 x 1)</p>	(1)

Question Number	Answer	Mark
10(b)(i)	<p>Any two of the following:</p> <ul style="list-style-type: none"> • Lockstitch • overlock • interlining • topstitching • flat bed cover seam/ cover seaming • adding buttons • button holing • adding pockets • riveting • binding • hemming • adding eyelets • adding elastic/ baby bonadex <p>Do not accept hand embroidery <i>1 mark per response up to 2</i></p> <p><i>Accept any recognisable spelling (phonetic) of the answers above.</i></p> <p style="text-align: right;">(2 x 1)</p>	(2)

Question Number	Answer	Mark
10(b)(ii)	<p>Appropriate explanation including two of the following points:</p> <ul style="list-style-type: none"> • quick method/fast production rate • produces 2-D shape/intricate shapes can be produced • little finishing required • unit costs are low • can be automated • or similar <p>Machine embroidery is used as it allows parts such as the appliqué to be produced quickly (1) and it creates a design more detailed than by hand (1).</p> <p>After the initial set up costs, the unit cost is low (1) and in most cases it can be easily automated (1).</p> <p><i>1 x 1 mark low response, or up to 2 for detailed response</i></p> <p style="text-align: right;">(2 x 1)</p>	(2)

Question Number	Answer	Mark
10(c)	<p>An explanation that makes reference to three of the following points:</p> <ul style="list-style-type: none"> • Improved wear resistance • Customer satisfaction • Extended life span of product • Easier manufacturing • Better functionality • More variation of products • Expanding designs • Any other appropriate response <p><i>Up to 3 x 1 mark low responses or up to 3 marks for a detailed response</i></p> <p style="text-align: right;">(3 x 1)</p>	(3)

Question Number	Answer	Mark
11(a)(i)	<p>One application such as:</p> <ul style="list-style-type: none"> • check physical damage (eg. tears) • check loose threads • size checks • broken needles check • functional checks (secure side seams) • Positional checks (eg. Buttons to button holes) • properties testing • or similar <p><i>Must be within production or assembly</i></p> <p style="text-align: right;">(1 x 1)</p>	(1)

Question Number	Answer	Mark
11(a)(ii)	<p>Description of how such as:</p> <ul style="list-style-type: none"> • check physical damage - by visual inspection (1) and checking against size chart and sketch (1) • check loose threads- by visual inspection (1) • size checks - by direct measurement or gauging (1) and checking against specification drawing (1) • broken needles check- through a metal detector (1) • functional checks - trying the dungarees out (1) by a wearer trial (1) • positional checks - measuring out (1) the button and button hole position against size chart (1) • properties testing - during wearer trial (1) and through a wash test(1) <p><i>Allow follow through up to 1 mark and if no answer in part 11 (a)(i) up to 1 mark for a correct answer.</i></p> <p style="text-align: right;">(2 x 1)</p>	(2)

Question Number	Answer	Mark
11(a)(iii)	<p>An explanation that makes reference to three of the following points:</p> <ul style="list-style-type: none"> • safer product to use • confidence in product reliability • consistent product • helps to maintain standards • longer useable life • don't have to buy as often • product reliability • confidence in the company • lower prices • any other appropriate response <p><i>Must relate to the wearer</i></p> <p style="text-align: right;">(3 x 1)</p>	(3)

Question Number	Answer	Mark
11(b)(i)	<p>One mark for stating the type of computer control</p> <ul style="list-style-type: none"> • CAD • Controlling output • CNC Machining centre • CAM • Robot / conveyor system • CIM • CIE • Programmable logic controllers PLCs <p><i>Must be within production or assembly</i></p> <p style="text-align: right;">(1 x 1)</p>	(1)

Question Number	Answer	Mark
11(b)(ii)	<p>Two marks for the description</p> <ul style="list-style-type: none"> • Downloads drawings (1) - to embroidery machines (1) • Modifies programmes / settings (1) - to alter manufacturing process (1) • Move / rotate / reposition parts (1) - to machining position (1) • Computer controls the positioning of the robot (1) to carry out a difficult manoeuvre (1) <p><i>1 mark for low response or 2 marks for detailed response</i></p> <p><i>If no computer control is stated or an inappropriate answer is given in 11(b)(i) allow follow through up to 1 mark for an appropriate description.</i></p> <p style="text-align: right;">(2 x 1)</p>	(2)

Question Number	Answer	Mark
11(c)	<p>An explanation that makes reference to three of the following points:</p> <ul style="list-style-type: none"> • makes sure current specification is always used during manufacture • safer production methods • product reliability / consistent product • ensures standards are met • lower costs / control of costs / more profit • less scrap / waste / more efficient • avoids faulty parts being assembled • early detection of problems • increased sales • user confidence / less returns • reduced waste • control of manufacturing process • monitoring standards testing / parts • no breaking parts • monitoring component / parts • any other appropriate response <p><i>1 x 1 mark low response, 3 x 1 mark 3 low responses or up to 3 for detailed response</i></p> <p style="text-align: right;">(3 x 1)</p>	(3)

Question Number	Answer	Mark
12(a)(i)	<p>Any two of the following:</p> <ul style="list-style-type: none"> • Analyse market research data in database • Cost the resource requirements for children's dungarees in spreadsheet • Plan marketing campaign using DTP software • Use of internet/website for marketing • Assists with pricing products • Or similar <p><i>1 mark per response up to 2</i></p> <p style="text-align: right;">(2 x 1)</p>	(2)

Question Number	Answer	Mark
12(a)(ii)	<p>One mark for identifying the use One mark for how</p> <ul style="list-style-type: none"> • Development of labelling (1) and / by electronic tagging protocol (1) • Electronic monitoring (1) of some packaging processes (1) • Use of bar codes (1) to monitor packaging / dispatch of children's dungarees (1) • Use of software (1) to record, log output of mechanics vices (1) • Any other appropriate response <p style="text-align: right;">(1 x 1)+(1 x 1)</p>	(2)

Question Number	Answer	Mark
12(b)	<p>One mark for identifying the benefit One mark for how</p> <ul style="list-style-type: none"> • Establishes a market database (1) shared with the manufacturer (1) • Has accurate costing information (1) shared with the manufacturer (1) / that can be manipulated easily (1) • Gives retailers opportunity to match the market needs (1) with production of children's dungarees (1) • Any other appropriate response <p style="text-align: right;">(1 x 1)+(1 x 1)</p>	(2)

Question Number	Answer	Mark
12(c)	<p>An explanation that makes reference to four of the following points:</p> <ul style="list-style-type: none"> • Fast time to market of latest model of children's dungarees • Use of ICT in market research enables manufacturer to match children's dungarees to market needs • Function / style information available for whole design team • Speed / efficiency of modelling • Modification of ideas • Ease/speed of creating virtual products • On screen design ideas • Speed of decision making by client • Easy access to design data • Working drawings / manufacturing specifications available for whole team • Easy access to manufacturing information in company database • Manufacturing time not wasted • Efficiency of costing materials • Speed of decision making for design team / client • Allows best materials to be used • Appropriate use of database • Modelling ensures characteristics are fit for purpose • Production process are controlled better • Improves aesthetics • Any other appropriate response <p style="text-align: right;">(4 x 1)</p>	(4)

Question Number	Answer	Mark
13(a)	<p>A explanation that makes reference to four of the following points to a maximum of four marks:</p> <p>On product cost up to a maximum of three marks</p> <ul style="list-style-type: none"> • Product costs are lower • PLCs controlling processes ensure scrap is not produced • Less manual labour required which is costly • Product cost would be higher if the demand for children's dungarees is not high • Higher maintenance costs could lead to higher product costs • Any other appropriate response <p>On introduction of new product designs up to a maximum of three marks</p> <ul style="list-style-type: none"> • Sometimes changing the automation will be lengthy • In some cases automation can be arranged to give flexible outputs from a production system • New designs / products may not always lend themselves to automation as well as old designs / products • Any other appropriate response <p style="text-align: right;">(4 x 1)</p>	(4)

Question Number	Answer	Mark
13(b)	<p>An evaluation that makes reference to four of the following points to a maximum of four marks:</p> <p>On the work force up to a maximum of three marks</p> <ul style="list-style-type: none"> • Less jobs • Change in skills • Less employment for unskilled • Change in size • Retraining often required • Different skills needed • Change in work patterns • Increased travel to work / centralisation • Working pattern / 24/7 operation • Job insecurity • Any other appropriate response <p>On the working environment up to a maximum of three marks</p> <ul style="list-style-type: none"> • Safer • Cleaner • Quieter • Healthier • Noise pollution • Any other appropriate response <p style="text-align: right;">(4 x 1)</p>	(4)
Total Marks for section B		(55)
Total marks for paper		(100)

Section A

Question Number	Answer	Mark
1(a)	<ul style="list-style-type: none"> • Metal door lock • Fire extinguisher <p><i>If three boxes ticked max marks = 1 mark. If 4 boxes or more ticked no marks.</i></p> <p style="text-align: right;">(2 x 1)</p>	(2)

Question Number	Answer	Mark
1(b)	<ul style="list-style-type: none"> • Waste skip • Suspension bridge <p><i>If three boxes ticked max marks = 1 mark. If 4 boxes or more ticked no marks.</i></p> <p style="text-align: right;">(2 x 1)</p>	(2)

Question Number	Answer	Mark
2(a)	<ul style="list-style-type: none"> • Rivet (accept any answer that makes reference to a specific rivet) e.g. <p>Solid rivet Cup head rivet Dome head rivet Mild steel rivet Snap head rivet Round head rivet</p> <p>Do not accept Pop rivet or blind rivet <i>Accept any recognisable spelling (phonetic) of the answers above.</i></p> <p style="text-align: right;">(1 x 1)</p>	(1)
	<ul style="list-style-type: none"> • Key (accept any answer that makes reference to a specific key) e.g. <p>Feather key Round edge key Jib key</p> <p><i>Accept any recognisable spelling (phonetic) of the answers above.</i></p> <p style="text-align: right;">(1 x 1)</p>	(1)

Question Number	Answer	Mark
2(b)	<p>An answer that makes reference to two of the following points:</p> <ul style="list-style-type: none"> • reduces friction • used on a shaft • helps rotation • gives a smooth action <p>e.g. Used to reduce friction (1) between a rotating and a stationary component (1)</p> <p style="text-align: right;">(2 x 1)</p>	(2)
	<p>An answer that makes reference to two of the following points:</p> <ul style="list-style-type: none"> • fixing two pieces of material together • screwing into a threaded fastener/material/nut • used with a nut • for temporary fixing / joining • used with a washer <p>e.g. A mechanical fastener used with a nut (1) to hold components together (1)</p> <p style="text-align: right;">(2 x 1)</p>	(2)

Question Number	Answer	Mark														
3	<p data-bbox="395 293 1150 394"><i>No mark awarded where 2 or more lines are drawn from a term. Lines do not have to be straight but term and key area must be clearly linked.</i></p> <div data-bbox="395 427 1166 1435"> <table border="0"> <thead> <tr> <th data-bbox="395 427 794 461">Term</th> <th data-bbox="900 427 1027 461">Key Area</th> </tr> </thead> <tbody> <tr> <td data-bbox="395 472 639 618">Continuous operation</td> <td data-bbox="799 472 1166 685">Information & Communications Technology (ICT)</td> </tr> <tr> <td data-bbox="395 663 639 786">Computer-aided design (CAD)</td> <td data-bbox="799 472 1166 685">Information & Communications Technology (ICT)</td> </tr> <tr> <td data-bbox="395 831 639 920">Databases</td> <td data-bbox="799 472 1166 685">Information & Communications Technology (ICT)</td> </tr> <tr> <td data-bbox="395 999 639 1088">Polymers</td> <td data-bbox="847 853 1134 1010">Control technology</td> </tr> <tr> <td data-bbox="395 1167 639 1256">Automation</td> <td data-bbox="847 853 1134 1010">Control technology</td> </tr> <tr> <td data-bbox="395 1335 639 1435">Composites</td> <td data-bbox="863 1200 1150 1357">Modern materials</td> </tr> </tbody> </table> </div> <p data-bbox="1078 1480 1161 1514">(6 x 1)</p>	Term	Key Area	Continuous operation	Information & Communications Technology (ICT)	Computer-aided design (CAD)	Information & Communications Technology (ICT)	Databases	Information & Communications Technology (ICT)	Polymers	Control technology	Automation	Control technology	Composites	Modern materials	(6)
Term	Key Area															
Continuous operation	Information & Communications Technology (ICT)															
Computer-aided design (CAD)	Information & Communications Technology (ICT)															
Databases	Information & Communications Technology (ICT)															
Polymers	Control technology															
Automation	Control technology															
Composites	Modern materials															

Question Number	Answer	Mark
4(a)(i)	<p>Appropriate product such as e.g</p> <ul style="list-style-type: none"> • Wheelbarrow • Cantilever Toolbox • BBQ • Darts • Mountain Bikes • Motorbikes • Cars • Filing Cabinets • Alloy Wheels • Scooters <p><i>Accept brand name of a specific product.</i></p> <p><i>This list is not exhaustive, accept any product that contains engineering fabrication componentry or is associated with the sector.</i></p> <p style="text-align: right;">(1 x 1)</p>	(1)

Question Number	Answer	Mark
4(a)(ii)	<p>Appropriate explanation of what the product does, may include reference to features and function</p> <p>E.g.</p> <ul style="list-style-type: none"> • Wheelbarrow - to transport heavy loads (1) manually from one place to another (1) • Toolbox - to allow tools to be carried (1) safe and securely (1) • BBQ - to cook (1) food (1) • Darts - to throw (1) at a dartboard (1) • Car - to transport (1) from one place to another (1) <p><i>If product given in 4(a)(i) is not from this sector but is from one of the other engineering manufacturing sectors then allow follow through up to one mark.</i></p> <p><i>No answer to 4(a)(i) no marks for 4(a)(ii)</i></p> <p style="text-align: right;">(2 x 1)</p>	(2)

Question Number	Answer	Mark
4(b)(i)	<ul style="list-style-type: none"> • design (1) marketing (1) production planning (1) materials - supply and control (1) processing/production (1) assembly/finishing (1) packaging/dispatch (1) <p><i>If product given in 4(a)(i) is not from this sector but is from one of the other engineering manufacturing sectors then allow follow through.</i></p> <p><i>No answer to 4(a)(i) no marks for 4(b)(i)</i></p> <p><i>Accept a process that is within any of the stages (e.g. using CAD, or using CAM) or (e.g. handling customer information) or (e.g. controlling packaging processes) must be appropriate to the product stated in 4(a)(i)</i></p> <p style="text-align: right;">(1 x 1)</p>	(1)

Question Number	Answer	Mark
4(b)(ii)	<p>One mark for identifying advantage One mark for why</p> <p>Appropriate advantage to the manufacturer e.g.</p> <p>Design, marketing, production planning, materials - supply and control, processing/production, assembly/finishing, packaging/dispatch</p> <p>design</p> <ul style="list-style-type: none"> • better designs (1) - can link other information into the process (1), or best designs can be maximised by simulation (1) • faster (1) - many CAD features such as copy, array can be used (1) or if mistakes made they can be quickly rectified (1) <p>marketing</p> <ul style="list-style-type: none"> • accurate information (1) - less mistakes made in capturing data (1) • better/accessible knowledge base (1) - easy data entry/data analysed easy (1) <p>production planning</p> <ul style="list-style-type: none"> • speed (1) - faster than human application (1) <p>materials - supply and control</p> <ul style="list-style-type: none"> • buy best available materials (1) - use of internet (1) • waste control (1) - by monitoring processes and quality control of processes (1) <p>processing/production</p> <p>Answer could relate to the application of CAM and control technology such as:-</p> <ul style="list-style-type: none"> • energy conservation (1) - by control of energy into process (1) • waste control (1) - by monitoring processes and quality control of processes(1) • competitiveness (1) - faster rates of production/application of CAM techniques (1) • product consistency (1) - by control of processes (1) • cost control (1) - by less waste/faulty parts (1) • efficiency (1) - by less waste/faulty parts (1) • speed (1) - faster than human application (1) 	

	<p>assembly/finishing Answer could relate to the application of CAM and control technology such as:-</p> <ul style="list-style-type: none"> • energy conservation (1) - by control of energy into process (1) • waste control (1) - by monitoring processes and quality control of processes(1) • product consistency (1) - by control of processes (1) • cost control (1) - by less waste/faulty parts (1) • efficiency (1) - by less waste/faulty parts (1) speed (1) - faster than human application (1) <p>packaging/dispatch Answer could relate to the application of CAM and control technology such as:-</p> <ul style="list-style-type: none"> • packaging consistency (1) - by control of processes (1) • cost control (1) - by less waste/faulty parts (1) • efficiency (1) - by less waste/faulty parts (1) • speed (1) - faster than human application (1) • energy conservation (1) - by control of energy into process (1) • waste control (1) - by monitoring processes and quality control of processes (1) <p><i>Low response (1) or two low responses (2) or detailed response (2)</i> <i>If the answer in part 4(b)(i) is not a manufacturing stage allow follow through up to 2 marks.</i> <i>No answer to 4(b)(i) no marks for 4(b)(ii)</i></p> <p style="text-align: right;">(1 x 1) + (1 x 1)</p>	(2)
--	---	-----

Question Number	Answer	Mark
4(c)(i)	<ul style="list-style-type: none"> • polymer / plastic (although plastic is not technically correct accept the term plastic) • adhesive • coating • metal • composite • shape memory alloy • ceramic • Other appropriate modern material - a material currently used for the given application <p><i>Accept brand name of a specific material</i></p> <p><i>If product given in 4(a)(i) is not from this sector but is from one of the other engineering manufacturing sectors then allow follow through.</i></p> <p><i>No answer to 4(a)(i) no marks for 4(c)(i)</i></p> <p style="text-align: right;">(1 x 1)</p>	(1)
Question Number	Answer	Mark
4(c)(ii)	<p>One mark for identifying improvement One mark for how</p> <ul style="list-style-type: none"> • smaller size (1) - miniaturisation (1) • lower weight (1) - better strength to weight ratio (1) • better appearance (1) - smoother/brighter finishes (1) • extends the life-time of product (1) - better wear characteristics (1) • improves wear resistance (1) - harder materials/better surface finish (1) • reduces cost (1) - overall product easier/earlier machineability (1) <p><i>If answer in part 4(a)(i) is inappropriate but the material given in 4(c)(i) is appropriate allow follow through up to 2 marks. If no answer is given in part 4(a)(i) but the answer to part 4(c)(ii) relates to the material stated in part 4(c)(i) allow follow through up to 1 mark. If no answer or incorrect answer given in part 4(c)(i) no marks awarded for 4(c)(ii).</i></p> <p style="text-align: right;">(1 x 1)+(1 x 1)</p>	(2)

Question Number	Answer	Mark
5(a)	<p>One mark for identifying the benefit One mark for how</p> <ul style="list-style-type: none"> • reduced ordering times (1) - automatic monitoring (1) • improve quality / accuracy (1) - control of processes (1) • reduced wastage (1) - optimise production methods (1) • improved efficiency (1) - faster / quicker throughput (1) • better process control (1) - in process monitoring (1) • reduced labour (1) - automated processes (1) • lower costs (1) - reduced wastage/faster/continuous production (1) • safer processes (1) - less manual input (1) <p><i>Do not accept 'easier' or 'faster' / 'quicker' without explanation.</i></p> <p><i>Low response (1) or two low responses (2) or detailed response (2), for each of 3 benefits</i></p> <p style="text-align: right;">(2 x 1) + (2 x 1) + (2 x 1)</p>	(6)

Question Number	Answer	Mark
5(b)	<p>One mark for identifying the reason One mark for how</p> <ul style="list-style-type: none"> • more consistent products (1) manufactured more accurately (1) • lower purchase price (1) faster production rates (1) • shorter order times (1) flexible methods used/variation in applied methods of production/faster production rates (1) • better quality/accurate product (1) processes controlled better/closer tolerances achieved (1) • customer satisfaction (1) better quality products produced (1) • consistent product (1) processes controlled better/closer tolerances achieved (1) • product guarantee (1) manufacturer has confidence in products produced/more reliable methods used (1) <p><i>Low response (1) or detailed statement (2) or two low responses (2)</i></p> <p style="text-align: right;">(1 x 1) + (1 x 1)</p>	(2)

Question Number	Answer	Mark
6(a)(i)	<p><i>Mark allocation 1 mark for a relevant type</i></p> <ul style="list-style-type: none"> • Mobile phone / infrared / bluetooth • Email / messaging • Internet / wireless / Wi-fi • Video conferencing • Electronic point of sale (EPOS) • EDI • ISDN • Texting • Phone • Walkie talkie • Fax <p><i>Do not accept: TV, CAD, radio, computer / laptop / database</i></p> <p style="text-align: right;">(1 x 1)</p>	(1)

Question Number	Answer	Mark
6(a)(ii)	<p>One mark for identifying the benefit One mark for how</p> <ul style="list-style-type: none"> • Mobile phone - can talk to supplier when needed (1) flexibility / roaming location (1) • Email - can send or receive instructions that are accurate/can get or send written confirmation of instructions (1) immediate permanent record (1) • Internet - can order and check stock immediately/in real time (1) immediate vast access to information (1) • Video conferencing -no travel expenses / less time wasted in travelling (1) but has face to face contact (1) • Electronic point of sale (EPOS) - faster / more accurate control of stock (1) automatic reading of bar codes (1) • EDI - immediate transfer of information / no hard copies needed / less storage space (1) by use of secure on-line facilities (1) • ISDN - more data transferred in parallel (1) faster response rate with supplier through use of technology (1) • Texting - can refer back to what message was given (1) stored record of transaction (1) • Phone - can clarify and confirm without having to re-visit the discussion later (1) immediate two way conversation (1) • Walkie talkie - can clarify and confirm without having to re-visit the discussion later (1) immediate two way conversation / flexibility / roaming location / cost (1) • Fax - can refer back to what message was given (1) stored record of transaction (1) <p>Other benefits may be seen in the light of:</p> <p>Speed, accuracy, JIT, information retrieval, meets consumer demands, quicker, increased sales, reduced stock levels, reduced running costs, reduced lead times, calculation of sales, stock taking quicker/easier, storage space reduced or any other appropriate reason</p> <p><i>Answer must relate to technology given in 6(a)(i)</i></p> <p><i>If part 6(a)(i) is not answered or answered incorrectly, no mark awarded for 6(a)(ii).</i></p> <p style="text-align: right;">(1 x 1) + (1 x 1)</p>	(2)

Question Number	Answer	Mark
6(b)(i)	<p>One mark for identifying the way One mark for how</p> <ul style="list-style-type: none"> • Email can send or receive attachments (1) such as databases or spreadsheets (1) • Internet use in real time (1) can transfer sales information immediately by data entry (1) • Automated distributor use of electronic point of sale (EPOS) (1) can transfer sales data by automatic reading of bar codes (1) • Distributors can use EDI (1) for immediate transfer of sales information by use of secure on-line facilities (1) • Fax can be used to show highlight sales figures only without detail (1) by typing into the messaging system (1) <p><i>Detailed statement required for 2, two low responses (1)</i></p> <p style="text-align: right;">(1 x 1) + (1 x 1)</p>	(2)

Question Number	Answer	Mark
6(b)(ii)	<p>One mark for each point made such as:</p> <p>Email</p> <ul style="list-style-type: none"> • distributor will have permanent record • can allow manufacturer to amend record sent • sends accurate information to respond to • can export information from own systems • limited ICT skills required • low cost <p>Internet</p> <ul style="list-style-type: none"> • doesn't need manual input • information given by the distributor is up to date • can use the internet information to plan marketing campaigns • online ordering • low cost <p>Distributors can use EDI</p> <ul style="list-style-type: none"> • doesn't need manual input • information given by the distributor is up to date • immediate response to sales • more responsive to stock movement • low cost <p>Fax</p> <ul style="list-style-type: none"> • does not give away all sales details to manufacturer • low cost • immediate hard copy • better medium for authorisation • limited ICT skills required <p><i>Do not accept any answers that suggest communications technology is free of charge or is no cost</i></p> <p><i>1 x 1 mark low response, 3 x 1 mark 3 low responses or up to 3 for detailed response</i></p> <p>if 6(b)(i) is not answered or answered incorrectly, but the answer to 6(b)(ii) identifies the communications technology; allow to follow through up to 2 marks</p> <p style="text-align: right;">(3 x 1)</p>	(3)

Question Number	Answer	Mark
7(a)	<p>One mark for each point made up to 2 marks such as:</p> <ul style="list-style-type: none"> • safer for operators/workers • can promote multiskilling • can handle hazardous processes • does not suffer from fatigue • does not make errors relative to safety aspects • more efficient/does not tire • less waste • once set up correctly will continue to produce to a given standard • can detect production/ process problems <p><i>Any other appropriate response.</i> <i>Low response (1) or detailed statement (2)</i></p> <p style="text-align: right;">(1 x 1)+(1 x 1)</p>	(2)

Question Number	Answer	Mark
7(b)	<p>One mark for each point made up to 2 marks such as:</p> <ul style="list-style-type: none"> • high set up costs • may have high running costs • may have high maintenance requirements • may not have flexibility in product range • may need close computer control to avoid mal-function <p><i>Any other appropriate response.</i> <i>Low response (1) or detailed statement (2)</i> <i>Do not accept "cost" without explanation</i></p> <p><i>Do not accept answers relating to less employees</i></p> <p style="text-align: right;">(1 x 1) + (1 x 1)</p>	(2)
Total marks for section A		(45)

Section B

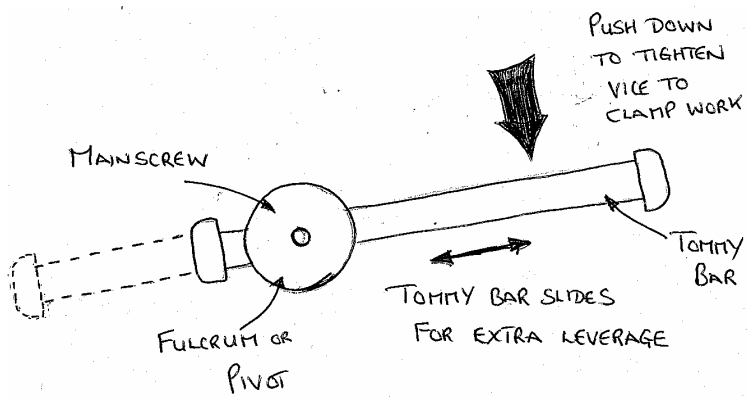
Question Number	Answer	Mark
8(a)	<p>An answer that makes reference to three of the following points:</p> <ul style="list-style-type: none"> • Used to open or close the vice jaws • Acts as a lever to make it easier to open or close the vice • The bar is not fixed so can be moved to allow different forces to be applied to it when opening and closing • Used to give mechanical advantage when holding work • Can make it easier to apply greater pressure for holding work <p><i>Answer must contain both notes and sketches. Max two marks if only notes or only sketches used.</i></p> <p><i>Eg.</i></p>  <p style="text-align: right;">(3 x 1)</p>	(3)

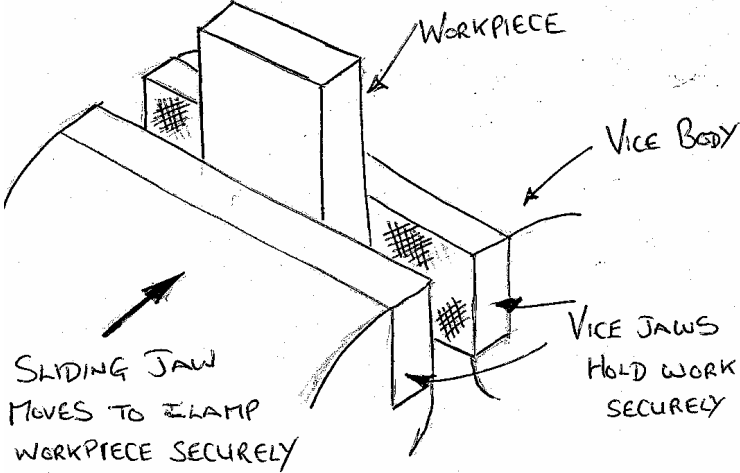
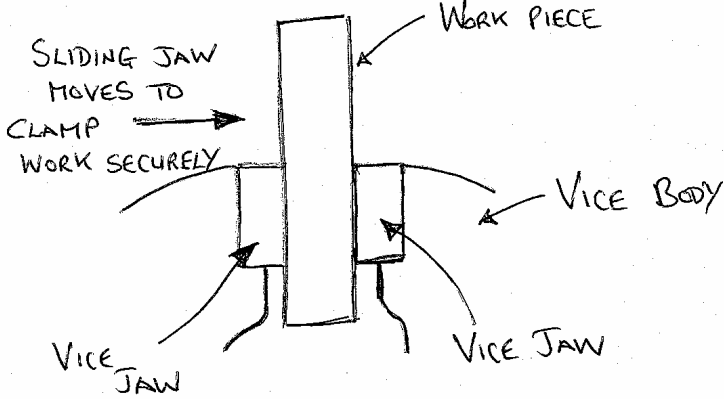
Question Number	Answer	Mark
8(b)	<p>An answer that makes reference to three of the following points:</p> <ul style="list-style-type: none"> • Holds work in vice tightly • Has a knurled finish to prevent work from slipping <p><i>Answer must contain both notes and sketches. Max two marks if only notes or only sketches used.</i></p> <p>Eg.</p>  <p>or</p>  <p>(3 x 1)</p>	(3)

Question Number	Answer	Mark
9(a)(i)	<ul style="list-style-type: none"> • Marketing • Production Planning or Planning <p>Do not accept production on its own</p> <p><i>Must be in this order</i></p> <p style="text-align: right;">(1 x 1) + (1 x 1)</p>	(2)

Question Number	Answer	Mark
9(a)(ii)	<ul style="list-style-type: none"> • Production/processing • Stage 5 / stage five • 5 / five <p><i>Accept any recognisable spelling (phonetic) of the answers above.</i></p> <p style="text-align: right;">(1 x 1)</p>	(1)

Question Number	Answer	Mark
9(b)(i)	<p>Appropriate descriptions including three of the following points:</p> <ul style="list-style-type: none"> • Fitting/attaching of parts together (any mention of any part being fitted/attached onto the vice) such as - • attaching the mainscrew/handle units to the vice slides • jaw plates are attached to the body and slide castings • Completing the assembly or sub-assembly of the vice • Parts are fitted/assembled in the correct order • Vice is tested to see if it works • Any other appropriate response <p>The stage where the mechanics vice is assembled (1) and the individual parts are fitted in the correct order (1). It is where the mainscrew is unwound to check the opening and closing action of the vice (1). Up to 3 marks</p> <p><i>1 x 1 mark low response, 3 x 1 mark 3 low responses or up to 3 for detailed response</i></p> <p style="text-align: right;">(3 x 1)</p>	(3)

Question Number	Answer	Mark
9(b)(ii)	<p>Appropriate descriptions including three of the following points:</p> <ul style="list-style-type: none"> • Application of protective packaging • Assembling orders • Application of codes, dates, tech info • Picking orders • Assembling loads • Packed individually into cardboard boxes • Making records • Application of box end labels to boxes • Sending to client • Final visual checks • Collation of multiple items • Any other appropriate response <p>The stage where the finished mechanics vices have any labels added (1), and are prepared for shipment (1) by the use of any protective materials (1) such as foam packaging or grease to prevent corrosion (1). The packaged vice is loaded onto the preferred method of dispatch (1) and carrier to be sent to the customer or distributor (1). Up to 3 marks</p> <p><i>1 x 1 mark low response, 3 x 1 mark 3 low responses or up to 3 for detailed response</i></p> <p style="text-align: right;">(3 x 1)</p>	(3)

Question Number	Answer	Mark
10(a)(i)	<p>Specific materials to make the mainscrew</p> <ul style="list-style-type: none"> • Steel or steel alloy or alloy steel • Mild Steel • Low Carbon Steel • Medium Carbon Steel • Carbon Steel <p><i>Accept any recognisable spelling (phonetic) of the answers above.</i></p> <p style="text-align: right;">(1 x 1)</p>	(1)

Question Number	Answer	Mark
10(a)(ii)	<p>Specific materials to make the vice body</p> <ul style="list-style-type: none"> • Cast iron • Grey iron • Ferrous alloy • Steel alloy • SG Iron/spheroidal graphite iron <p><i>Accept any recognisable spelling (phonetic) of the answers above.</i></p> <p style="text-align: right;">(1 x 1)</p>	(1)

Question Number	Answer	Mark
10(b)(i)	<p>Any three of the following:</p> <ul style="list-style-type: none"> • drilling • turning • milling • grinding • broaching • cold forming • boring • hardening/surface hardening/tempering • annealing/normalising • polishing/coating/painting/powder coating/plating • honing • Painting • Powder coating • Spray painting • Hot dipping • Electrostatic painting • Welding • Tapping • Dye Cutting <p>Do not accept moulding <i>1 mark per response up to 3</i></p> <p><i>Accept any recognisable spelling (phonetic) of the answers above..</i></p> <p style="text-align: right;">(3 x 1)</p>	(3)

Question Number	Answer	Mark
10(b)(ii)	<p>Appropriate explanation including two of the following points:</p> <ul style="list-style-type: none"> • simplest type of casting method to perform • produces 3-D shapes easily • strong rigid products are produced • green sand can be re-used • unit costs are low • can be automated • easiest for making large parts/components • or similar <p>Casting is used as it allows parts such as the vice body to be produced quickly(1) with easy removal of any excess material (1).</p> <p>After the initial set up costs, the unit cost is low (1) and in some cases it can be easily automated (1).</p> <p>Simple process that requires no expensive dyes (1). Vice body does not require a high quality finish so texture of sand is acceptable (1).</p> <p><i>1 x 1 mark low response, or up to 2 for detailed response</i></p> <p style="text-align: right;">(2 x 1)</p>	(2)

Question Number	Answer	Mark
10(c)	<p>An explanation that makes reference to three of the following points:</p> <ul style="list-style-type: none"> • Improved wear resistance • Longer lasting parts such as the mainscrew • Moving products needed less maintenance • Easier manufacturing • Better functionality • More variation of products • Expanding markets (DIY, School) i.e. smaller vices doing similar work to older models etc • Smaller components • Improved aesthetics • Reduced costs • Environmental improvements • Any other appropriate answer <p><i>Up to 3 x 1 mark low responses or up to 3 marks for a detailed response</i></p> <p style="text-align: right;">(3 x 1)</p>	(3)

Question Number	Answer	Mark
11(a)(i)	<p>One application such as:</p> <ul style="list-style-type: none"> • check physical damage • size checks • functional checks • positional and dimensional checks • length of material / surface finish • holes drilled / slots milled in main body • properties testing • or similar <p><i>Must be within production or assembly</i></p>	(1)

Question Number	Answer	Mark
11(a)(ii)	<p>Description of how such as:</p> <ul style="list-style-type: none"> • check physical damage - by visual inspection (1) and checking against drawing (1) • size checks - by direct measurement or gauging (1) and checking against drawing (1) • functional checks - use test rig (1) and trying the vice out (1) • positional and dimensional checks - use of co-ordinate measuring machine (1) and analysing reported data (1) - check jaw plate alignment (1) • length of material / surface finish - use of variable quality indicator / probe (1) and comparing with preferred or standard values (1) • holes drilled / slots milled in vice body - use of gauges (1) and inspection equipment / techniques (1) • properties testing - in system testing / hardness testing (1) • ultrasound (1) - testing for cracks/blowholes/porosity(1) <p><i>Allow follow through up to 1 mark and if no answer in part 11(a)(i) up to 1 mark for a correct answer.</i></p>	(2)

Question Number	Answer	Mark
11(a)(iii)	<p>An explanation that makes reference to three of the following points:</p> <ul style="list-style-type: none"> • safer product to use • confidence in product reliability • consistent product • helps to maintain standards • longer useable life • don't have to buy as often • product reliability • confidence in the company • lower prices • any other appropriate response <p><i>Must relate to the user</i></p> <p style="text-align: right;">(3 x 1)</p>	(3)

Question Number	Answer	Mark
11(b)(i)	<p>One mark for stating the type of computer control</p> <ul style="list-style-type: none"> • CAD • Controlling output • CNC/ Machining centre • CAM • Robot / conveyor system • CIM • CIE • Programmable logic controllers PLCs • Must be within production or assembly <p style="text-align: right;">(1 x 1)</p>	(1)

Question Number	Answer	Mark
11(b)(ii)	<p>Two marks for the description</p> <ul style="list-style-type: none"> • Downloads drawings (1) - to machines (1) • Modifies programmes / settings (1) - to alter manufacturing process (1) • Move / rotate / reposition parts (1) - to machining position (1) • Computer controls the positioning of the robot (1) to carry out a difficult manoeuvre (1) <p>1 mark for low response or 2 marks for detailed response</p> <p><i>If no computer control is stated or an inappropriate answer is given in 11(b)(i) allow follow through up to 1 mark for an appropriate description.</i></p> <p style="text-align: right;">(2 x 1)</p>	(2)

Question Number	Answer	Mark
11(c)	<p>An explanation that makes reference to three of the following points:</p> <ul style="list-style-type: none"> • makes sure current specification is always used during manufacture • safer production methods • product reliability / consistent product • ensures standards are met • lower costs / control of costs / more profit • less scrap / waste / more efficient • avoids faulty parts being assembled • early detection of problems • increased sales • user confidence / less returns • reduced waste • control of manufacturing process • monitoring standards testing / parts • no breaking parts • monitoring component / parts • any other appropriate response <p><i>1 x 1 mark low response, 3 x 1 mark 3 low responses or up to 3 for detailed response</i></p> <p style="text-align: right;">(3 x 1)</p>	(3)

Question Number	Answer	Mark
12(a)(i)	<p>Any two of the following:</p> <ul style="list-style-type: none"> • Analyse market research data in database • Assists with pricing products • Cost the resource requirements for mechanics vices in spreadsheet • Plan marketing campaign using DTP software • Use of internet/website for marketing • Or similar <p><i>1 mark per response up to 2</i></p> <p style="text-align: right;">(2 x 1)</p>	(2)

Question Number	Answer	Mark
12(a)(ii)	<p>One mark for identifying the use One mark for how:</p> <ul style="list-style-type: none"> • Development of labelling (1) and / by electronic tagging protocol (1) • Electronic monitoring (1) of some packaging processes (1) • Use of bar codes (1) to monitor packaging / dispatch of mechanics vices (1) • Use of software (1) to record, log output of mechanics vices (1) • Any other appropriate response <p style="text-align: right;">(1 x 1) + (1 x 1)</p>	(2)

Question Number	Answer	Mark
12(b)	<p>One mark for identifying the benefit One mark for how</p> <ul style="list-style-type: none"> • Establishes a market database (1) shared with the manufacturer (1) • Has accurate costing information (1) shared with the manufacturer (1) / that can be manipulated easily (1) • Gives distributors opportunity to match the market needs (1) with production of mechanics vices (1) • Any other appropriate response <p style="text-align: right;">(1 x 1) + (1 x 1)</p>	(2)

Question Number	Answer	Mark
12(c)	<p>An explanation that makes reference to four of the following points:</p> <ul style="list-style-type: none"> • Fast time to market of latest model of mechanics vices • Use of ICT in market research enables manufacturer to match mechanics vices to market needs • Function / style information available for whole design team • Speed / efficiency of modelling • Modification of ideas • Ease/speed of creating virtual products • On screen design ideas • Speed of decision making by client • Easy access to design data • Working drawings / manufacturing specifications available for whole team • Easy access to manufacturing information in company database • Manufacturing time not wasted • Efficiency of costing materials • Speed of decision making for design team / client • Allows best materials to be used • Appropriate use of database • Modelling ensures characteristics are fit for purpose • Production process are controlled better • Improved aesthetics • Any other appropriate response <p style="text-align: right;">(4 x 1)</p>	(4)

Question Number	Answer	Mark
13(a)	<p>A explanation that makes reference to four of the following points to a maximum of four marks:</p> <p>On product cost up to a maximum of three marks</p> <ul style="list-style-type: none"> • Product costs are lower • PLCs controlling processes ensure scrap is not produced • Less manual labour required which is costly • Product cost would be higher if the demand for the mechanics vice is not high • Any other appropriate response • Higher maintenance costs could lead to higher product costs <p>On introduction of new product designs up to a maximum of three marks</p> <ul style="list-style-type: none"> • Sometimes changing the automation will be lengthy • In some cases automation can be arranged to give flexible outputs from a production system • New designs / products may not always lend themselves to automation as well as old designs / products • Any other appropriate response <p style="text-align: right;">(4 x 1)</p>	(4)

Question Number	Answer	Mark
13(b)	<p>An evaluation that makes reference to four of the following points to a maximum of four marks:</p> <p>On the work force up to a maximum of three marks</p> <ul style="list-style-type: none"> • Less jobs • Change in skills • Less employment for unskilled • Change in size • Retraining often required • Different skills needed • Change in work patterns • Increased travel to work / centralisation • Working pattern / 24/7 operation • Job insecurity • Any other appropriate response <p>On the working environment up to a maximum of three marks</p> <ul style="list-style-type: none"> • Safer • Cleaner • Quieter • Healthier • Noise pollution • Any other appropriate response <p style="text-align: right;">(4 x 1)</p>	(4)
Total Marks for section B		(55)
Total marks for paper		(100)

Section A

Question Number	Answer	Mark
1(a)	<ul style="list-style-type: none"> • Flat screen TV • Fridge <p><i>If three boxes ticked max marks = 1 mark. If 4 boxes or more ticked no marks.</i></p> <p style="text-align: right;">(2 x 1)</p>	(2)

Question Number	Answer	Mark
1(b)	<ul style="list-style-type: none"> • Microprocessor • Mouse <p><i>If three boxes ticked max marks = 1 mark. If 4 boxes or more ticked no marks.</i></p> <p style="text-align: right;">(2 x 1)</p>	(2)

Question Number	Answer	Mark
2(a)	<ul style="list-style-type: none"> • Diode (accept any answer that makes reference to a specific diode) e.g <p>Zener diode Power diode Silicon diode Germanium diode Small signal diode</p> <p>Do not accept rectifier/Light Emitting Diode/LED <i>Accept any recognisable spelling (phonetic) of the answers above.</i></p> <p style="text-align: right;">(1 x 1)</p>	(1)
	<ul style="list-style-type: none"> • Motor (accept any answer that makes reference to a specific motor) e.g <p>Stepper motor Dc motor Permanent magnet motor</p> <p>Do not accept AC motor/Induction motor <i>Accept any recognisable spelling (phonetic) of the answers above.</i></p> <p style="text-align: right;">(1 x 1)</p>	(1)

Question Number	Answer	Mark
2(b)	<p>An answer that makes reference to two of the following points:</p> <ul style="list-style-type: none"> • Used as a switch • used as an amplifier • has a high gain • switches low voltage to high voltage • input signal to output signal • Amplifies Current <p>e.g used to increase the output signal(1) when used as an amplifier (1)</p> <p style="text-align: right;">(2 x 1)</p>	(2)
	<p>An answer that makes reference to two of the following points:</p> <ul style="list-style-type: none"> • used in electronic circuits to give a warning • converts electrical energy into sound energy • sounds a warning in the form of a sound • electronic signalling device • Application - such as doorbell <p>e.g. converts electrical energy into sound energy (1) in electronic circuits to provide a warning (1)</p> <p style="text-align: right;">(2x 1)</p>	(2)

Question Number	Answer	Mark
3	<p data-bbox="391 324 1157 436"><i>No mark awarded where 2 or more lines are drawn from a term. Lines do not have to be straight but term and key area must be clearly linked.</i></p> <div data-bbox="391 459 1173 1467"> <p data-bbox="391 459 478 492">Term</p> <p data-bbox="893 459 1029 492">Key Area</p> <pre> graph LR subgraph Terms C[Continuous operation] CAD[Computer-aided design (CAD)] D[Databases] P[Polymers] A[Automation] LC[Liquid crystals] end subgraph KeyAreas ICT([Information & Communications Technology (ICT)]) CT([Control technology]) MM([Modern materials]) end C --- ICT CAD --- ICT D --- ICT P --- CT A --- CT LC --- MM </pre> </div> <p data-bbox="1077 1512 1165 1545">(6 x 1)</p>	(6)

Question Number	Answer	Mark
4(a)(i)	<p>Appropriate product such as e.g</p> <ul style="list-style-type: none"> • mobile phone • tv • digital camera • mp3 player • computer • satellite dish • portable electric drill • soldering iron <p><i>Accept brand name of a specific product.</i></p> <p><i>This list is not exhaustive, accept any product that contains electrical/electronic componentry or association with the sector.</i></p> <p style="text-align: right;">(1 x 1)</p>	(1)

Question Number	Answer	Mark
4(a)(ii)	<p>Appropriate explanation of what the product does, may include reference to features and function</p> <p>E.g.</p> <p>Mobile phone-long range portable device (1) used for mobile communication(1)</p> <p>TV- telecommunication system (1) for broadcasting and receiving moving pictures and sound over a distance</p> <p>Digital camera-To take pictures (1) and store them on disk (1)</p> <p><i>If product given in 4(a)(i) is not from this sector but is from one of the other engineering manufacturing sectors then allow follow through up to one mark.</i></p> <p><i>No answer to 4(a)(i) no marks for 4(a)(ii)</i></p> <p style="text-align: right;">(2 x 1)</p>	(2)

Question Number	Answer	Mark
4(b)(i)	<ul style="list-style-type: none"> • design (1) marketing (1) production planning (1) materials - supply and control (1) processing/production (1) assembly/finishing (1) packaging/dispatch (1) <p><i>If product given in 4(a)(i) is not from this sector but is from one of the other engineering manufacturing sectors then allow follow through.</i></p> <p><i>No answer to 4(a)(i) no marks for 4(b)(i)</i></p> <p><i>Accept a process that is within any of the stages (e.g using CAD, or using CAM) or (e.g. handling customer information) or (e.g. controlling packaging processes) must be appropriate to the product stated in 4(a)(i)</i></p> <p style="text-align: right;">(1 x 1)</p>	(1)

Question Number	Answer	Mark
4(b)(ii)	<p>One mark for identifying advantage One mark for why</p> <p>Appropriate advantage to the manufacturer e.g.</p> <p>Design, marketing, production planning, materials - supply and control, processing/production, assembly/finishing, packaging/dispatch</p> <p>design</p> <ul style="list-style-type: none"> • better designs (1) - can link other information into the process (1), or best designs can be maximised by simulation (1) • faster (1) - many CAD features such as copy, array can be used (1) or if mistakes made they can be quickly rectified (1) <p>marketing</p> <ul style="list-style-type: none"> • accurate information (1) - less mistakes made in capturing data (1) • better/accessible knowledge base (1) - easy data entry/data analysed easy (1) <p>production planning</p> <ul style="list-style-type: none"> • speed (1) - faster than human application (1) <p>materials - supply and control</p> <ul style="list-style-type: none"> • buy best available materials (1) - use of internet (1) • waste control (1) - by monitoring processes and quality control of processes (1) <p>processing/production</p> <p>Answer could relate to the application of CAM and control technology such as:-</p> <ul style="list-style-type: none"> • energy conservation (1) - by control of energy into process (1) • waste control (1) - by monitoring processes and quality control of processes(1) • competitiveness (1) - faster rates of production/application of CAM techniques (1) • product consistency (1) - by control of processes (1) • cost control (1) - by less waste/faulty parts (1) • efficiency (1) - by less waste/faulty parts (1) • speed (1) - faster than human application (1) 	

	<p>assembly/finishing Answer could relate to the application of CAM and control technology such as:-</p> <ul style="list-style-type: none"> • energy conservation (1) - by control of energy into process (1) • waste control (1) - by monitoring processes and quality control of processes(1) • product consistency (1) - by control of processes (1) • cost control (1) - by less waste/faulty parts (1) • efficiency (1) - by less waste/faulty parts (1) speed (1) - faster than human application (1) <p>packaging/dispatch Answer could relate to the application of CAM and control technology such as:-</p> <ul style="list-style-type: none"> • packaging consistency (1) - by control of processes (1) • cost control (1) - by less waste/faulty parts (1) • efficiency (1) - by less waste/faulty parts (1) • speed (1) - faster than human application (1) • energy conservation (1) - by control of energy into process (1) • waste control (1) - by monitoring processes and quality control of processes (1) <p><i>Low response (1) or two low responses (2) or detailed response (2)</i> <i>If the answer in part 4(b)(i) is not a Manufacturing stage allow follow through up to 2 marks.</i></p> <p><i>No answer to 4(b)(i) no marks for 4(b)(ii)</i></p>	<p style="text-align: right;">(1 x 1)+(1 x 1) (2)</p>
--	---	--

Question Number	Answer	Mark
4(c)(i)	<ul style="list-style-type: none"> • polymer / plastic (although plastic is not technically correct accept the term plastic) • adhesive • coating • metal • composite • shape memory alloy • ceramic • Other appropriate modern material - a material currently used for the given application • ABS etc <p><i>Accept brand name of a specific material</i></p> <p><i>If product given in 4(a)(i) is not from this sector but is from one of the other engineering manufacturing sectors then allow follow through.</i></p> <p><i>No answer to 4(a)(i) no marks for 4(c)(i)</i></p> <p style="text-align: right;">(1 x 1)</p>	(1)

Question Number	Answer	Mark
4(c)(ii)	<p>One mark for identifying improvement One mark for how</p> <ul style="list-style-type: none"> • smaller size (1) - miniaturisation (1) • lower weight (1) - better strength to weight ratio (1) • better appearance (1) - smoother/brighter finishes (1) • extends the life-time of product (1) - better wear characteristics (1) • improves wear resistance (1) - harder materials/better surface finish (1) • reduces cost (1) - overall product easier/earlier machine ability (1) <p><i>If answer in part 4(a)(i) is inappropriate but the material given in 4(c)(i) is appropriate allow follow through up to 2 marks. If no answer is given in part 4(a)(i) but the answer to part 4 (c)(ii) relates to the material stated in part 4(c)(i) allow follow through up to 1 mark. If no answer or incorrect answer given in part 4 (c)(i) no marks awarded for 4(c)(ii).</i></p> <p style="text-align: right;">(1 x 1)+(1 x 1)</p>	(2)

Question Number	Answer	Mark
5(a)	<p>One mark for identifying the benefit One mark for how</p> <ul style="list-style-type: none"> • reduced ordering times (1) - automatic monitoring (1) • improve quality / accuracy (1) - control of processes (1) • reduced wastage (1) - optimise production methods (1) • improved efficiency (1) - faster / quicker throughput (1) • better process control (1) - in process monitoring (1) • reduced labour (1) - automated processes (1) • lower costs (1) - reduced wastage/faster/continuous production (1) • safer processes (1) - less manual input (1) <p><i>Do not accept easier without explanation.</i></p> <p><i>Low response (1) or two low responses (2) or detailed response (2), for each of 3 benefits</i></p> <p style="text-align: right;">(2 x 1)+(2 x 1)+(2 x 1)</p>	(6)

Question Number	Answer	Mark
5(b)	<p>One mark for identifying the reason One mark for how</p> <ul style="list-style-type: none"> • more consistent products (1) manufactured more accurately (1) • lower purchase price (1) faster production rates (1) • shorter order times (1) flexible methods used/variation in applied methods of production/faster production rates (1) • better quality/accurate product (1) processes controlled better/closer tolerances achieved (1) • customer satisfaction (1) better quality products produced (1) • consistent product (1) processes controlled better/closer tolerances achieved (1) • product guarantee (1) manufacturer has confidence in products produced/more reliable methods used (1) <p><i>Low response (1) or detailed statement (2) or two low responses (2)</i></p> <p style="text-align: right;">(1 x)+ (1 x 1)</p>	(2)

Question Number	Answer	Mark
6(a)(i)	<p><i>Mark allocation 1 for a relevant type</i></p> <ul style="list-style-type: none"> • Mobile phone / infrared / bluetooth • Email / messaging • Internet / wireless / Wi-fi • Video conferencing • Electronic point of sale (EPOS) • EDI • ISDN • Texting • Phone • Walkie talkie • Fax <p><i>Do not accept: TV, CAD, radio, computer / laptop / database</i></p> <p style="text-align: right;">(1 x 1)</p>	(1)

Question Number	Answer	Mark
6(a)(ii)	<p>One mark for identifying the benefit One mark for how</p> <ul style="list-style-type: none"> • Mobile phone - can talk to supplier when needed (1) flexibility / roaming location (1) • Email - can send or receive instructions that are accurate/can get or send written confirmation of instructions (1) immediate permanent record (1) • Internet - can order and check stock immediately/in real time (1) immediate vast access to information (1) • Video conferencing -no travel expenses / less time wasted in travelling (1) but has face to face contact (1) • Electronic point of sale (EPOS) - faster / more accurate control of stock (1) automatic reading of bar codes (1) • EDI - immediate transfer of information / no hard copies needed / less storage space (1) by use of secure on-line facilities (1) • ISDN - more data transferred in parallel (1) faster response rate with supplier through use of technology (1) • Texting - can refer back to what message was given (1) stored record of transaction (1) • Phone - can clarify and confirm without having to re-visit the discussion later (1) immediate two way conversation (1) • Walkie talkie - can clarify and confirm without having to re-visit the discussion later (1) immediate two way conversation / flexibility / roaming location / cost (1) • Fax - can refer back to what message was given (1) stored record of transaction (1) <p>Other benefits may be seen in the light of: Speed, accuracy, JIT, information retrieval, meets consumer demands, quicker, increased sales, reduced stock levels, reduced running costs, reduced lead times, calculation of sales, stock taking quicker/easier, storage space reduced or any other appropriate reason</p> <p><i>Answer must relate to technology given in 6(a)(i) If part 6(a)(i) is not answered or answered incorrectly no mark awarded for 6(a)(ii) If 6(b)(i) is not answered or is answered incorrectly but the answer to 6(b)(ii) identifies the communications technology; allow follow through up to 2 marks.</i></p> <p style="text-align: right;">(1 x 1)+(1 x 1)</p>	(2)

Question Number	Answer	Mark
6(b)(i)	<p>One mark for identifying the way One mark for how</p> <ul style="list-style-type: none"> • Email can send or receive attachments (1) such as databases or spreadsheets (1) • Internet use in real time (1) can transfer sales information immediately by data entry (1) • Automated retailer use of electronic point of sale (EPOS) (1) can transfer sales data by automatic reading of bar codes (1) • Retailers can use EDI (1) for immediate transfer of sales information by use of secure on-line facilities (1) • Fax can be used to show highlight sales figures only without detail (1) by typing into the messaging system (1) <p><i>Detailed statement required for 2, two low responses (1)</i></p> <p style="text-align: right;">(1 x 1)+(1 x 1)</p>	(2)

Question Number	Answer	Mark
6(b)(ii)	<p>One mark for each point made such as:</p> <p>Email</p> <ul style="list-style-type: none"> • retailer will have permanent record • can allow manufacturer to amend record sent • sends accurate information to respond to • can export information from own systems • limited ICT skills required • low cost <p>Internet</p> <ul style="list-style-type: none"> • doesn't need manual input • information given by the retailer is up to date • can use the internet information to plan marketing campaigns • online ordering • low cost <p>Retailers can use EDI</p> <ul style="list-style-type: none"> • doesn't need manual input • information given by the retailer is up to date • immediate response to sales • more responsive to stock movement • low cost <p>Fax</p> <ul style="list-style-type: none"> • does not give away all sales details to manufacturer • low cost • immediate hard copy • better medium for authorisation • limited ICT skills required <p><i>Do not accept any answers that suggest communications technology is free of charge or is no cost</i></p> <p><i>1 x 1 mark low response, 3 x 1 mark 3 low responses or up to 3 for detailed response</i></p> <p style="text-align: right;">(3 x 1)</p>	(3)

Question Number	Answer	Mark
7(a)	<p>One mark for each point made up to 2 marks such as:</p> <ul style="list-style-type: none"> • safer for operators/workers • can handle hazardous processes • does not suffer from fatigue • does not make errors relative to safety aspects • more efficient/does not tire • less waste • once set up correctly will continue to produce to a given standard • can detect production/process problems • can promote multiskilling <p><i>Any other appropriate response.</i> <i>Low response (1) or detailed statement (2)</i></p> <p style="text-align: right;">(1 x 1)+(1 x 1)</p>	(2)

Question Number	Answer	Mark
7(b)	<p>One mark for each point made up to 2 marks such as:</p> <ul style="list-style-type: none"> • high set up costs • may have high running costs • may have high maintenance requirements • may not have flexibility in product range • may need close computer control to avoid mal-function <p><i>Any other appropriate response.</i> <i>Low response (1) or detailed statement (2)</i> Do not accept "cost" without an explanation</p> <p>Do not accept answers relating to less employees</p> <p style="text-align: right;">(1 x 1)+(1 x 1)</p>	(2)
Total marks for section A		(45)

Section B

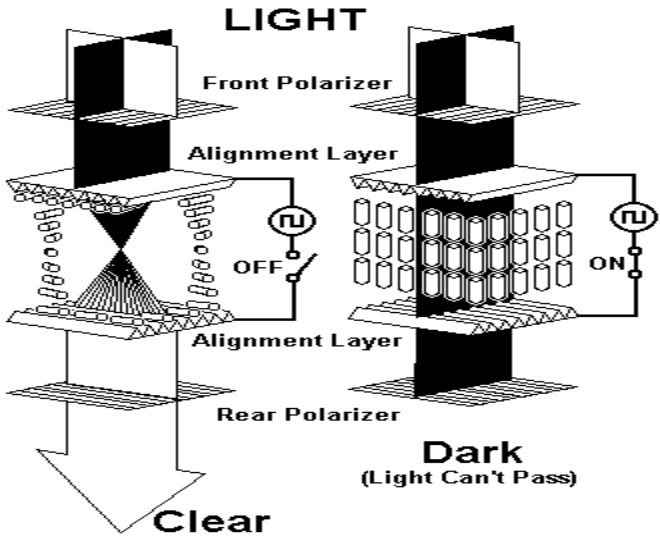
Question Number	Answer	Mark
8(a)	<p>An answer that makes reference to three of the following points:</p> <ul style="list-style-type: none"> • A digital display for showing numbers or letters • Makes display easy to read • Displays on a flat screen • Provides the display using very little power/electricity/current etc • Provides a light weight display <p><i>Not strictly a function but will accept a definition of operation</i></p> <ul style="list-style-type: none"> • Consists of two sheets of polarizing material • Liquid crystal solution • Electric current passes through • Display by shining light through crystals <p><i>Answer must contain both notes and sketches. Max two marks if only notes or only sketches used.</i></p> <p><i>Eg.</i></p>  <p>The diagram illustrates the operation of an LCD. It shows two cross-sectional views of the display. The left view is labeled 'OFF' and shows light passing through a 'Front Polarizer', an 'Alignment Layer' with liquid crystals twisted 90 degrees, and a 'Rear Polarizer', resulting in a 'Clear' display. The right view is labeled 'ON' and shows an electric current (represented by a battery symbol and a switch) passing through the 'Alignment Layer', which aligns the liquid crystals vertically, blocking light from passing through the 'Rear Polarizer', resulting in a 'Dark (Light Can't Pass)' display.</p>	

OR

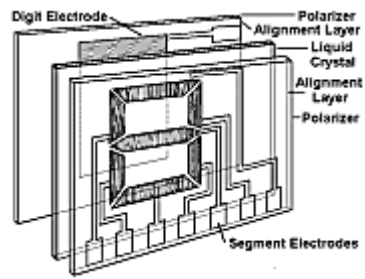

OR



(3 x 1)

(3)

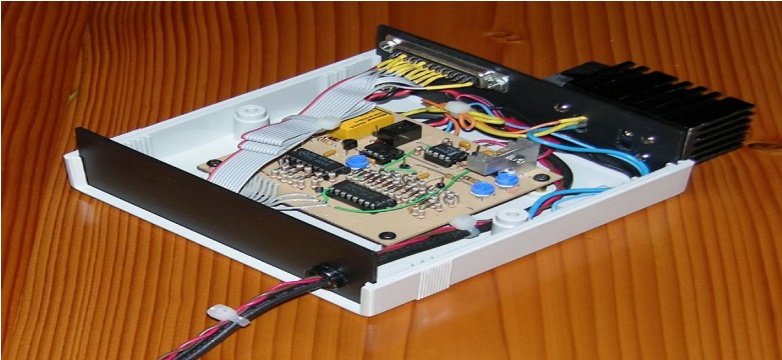
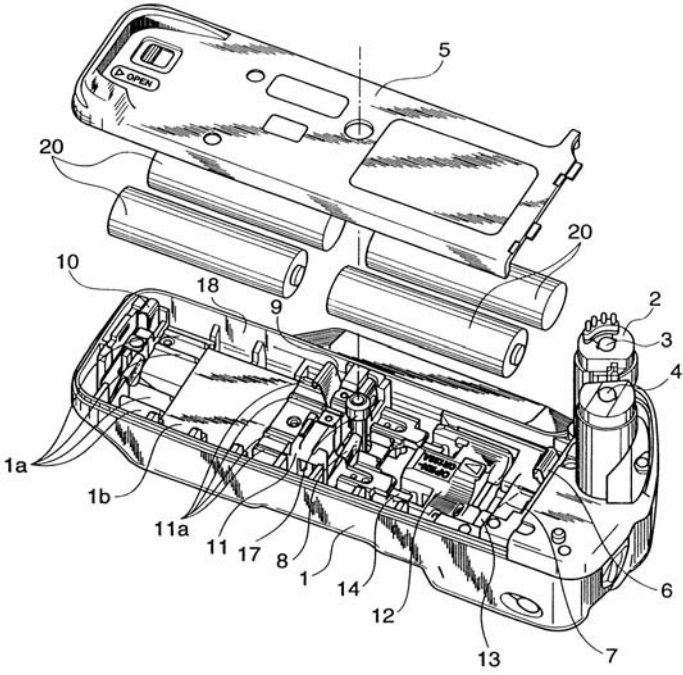
Question Number	Answer	Mark
8(b)	<p>An answer that makes reference to three of the following points:</p> <ul style="list-style-type: none"> • Holds components together • Provides mechanical protection • Provides an attractive enclosure • Container for battery • Allows aesthetic designs to be utilised • Easy to produce, allows complex shapes of the case <p><i>Answer must contain both notes and sketches. Max two marks if only notes or only sketches used. Eg.</i></p>  <p>or</p>  <p style="text-align: right;">(3 x 1)</p>	(3)

Question Number	Answer	Mark
9(a)(i)	<ul style="list-style-type: none"> • Marketing • Production Planning or Planning or Plan Do not accept production on its own <i>Must be in this order</i>	(2)
	(1 x 1)+(1 x 1)	

Question Number	Answer	Mark
9(a)(ii)	<ul style="list-style-type: none"> • Production/processing • Stage 5 / stage five • 5 / five <i>Accept any recognisable spelling (phonetic) of the answers above.</i>	(1)
	(1 x 1)	

Question Number	Answer	Mark
9(b)(i)	Appropriate descriptions including three of the following points: <ul style="list-style-type: none"> • Fitting of parts together (any mention of any part being fitting into the clock, such as - fitting components to pcb) • Completing the assembly or sub-assembly of the clock • Parts are fitted/assembled in the correct order • Where the wiring is done • Clock is operated to see if it works • Any other appropriate response The stage where the LCD alarm clock is assembled (1) and the individual parts are fitted in the correct order (1). It is where the final wiring is done (1) and the clock is checked to see if it operates (1). Up to 3 marks <i>1 x 1 mark low response, 3 x 1 mark 3 low responses or up to 3 for detailed response</i>	(3)
	(3 x 1)	

Question Number	Answer	Mark
9(b)(ii)	<p>Appropriate descriptions including three of the following points:</p> <ul style="list-style-type: none"> • Application of protective packaging • Assembling orders • Application of codes, dates, tech info • Picking orders • Assembling loads • Packing into outer boxes • Making records • Application of labels to boxes • Sending to client • Final visual checks • Collation of multiple items • Any other appropriate response <p>The stage where the finished LCD alarm clocks have any labels added (1), and are prepared for shipment (1) by the use of any protective materials such as bubble wrap (1). The packaged drill is loaded onto the preferred method of dispatch and carrier (1) to be sent to the customer or retailer (1). Up to 3 marks</p> <p><i>1 x 1 mark low response, 3 x 1 mark 3 low responses or up to 3 for detailed response</i></p> <p style="text-align: right;">(3 x 1)</p>	(3)

Question Number	Answer	Mark
10(a)(i)	<p>Specific materials to make the function buttons</p> <ul style="list-style-type: none"> • Rubber • Chromed polymer/plastic/metal • Stainless steel • PVC • Polythene -Low density /High density • Aluminium alloys <p><i>Accept any recognisable spelling (phonetic) of the answers above..</i></p> <p style="text-align: right;">(1 x 1)</p>	(1)

Question Number	Answer	Mark
10(a)(ii)	<p>Specific materials to make the outer casing</p> <ul style="list-style-type: none"> • Thermo plastic • ABS - Acrylonitrile-butadiestyrene • Acetate - cellulose • Polythene -Low density /High density • Aluminium alloys <p><i>Accept any recognisable spelling (phonetic) of the answers above.</i></p> <p style="text-align: right;">(1 x 1)</p>	(1)

Question Number	Answer	Mark
10(a)(iii)	<p>Specific materials to make the printed circuit board</p> <ul style="list-style-type: none"> • Copper/copper foil • Phenolic paper • Glass fibre • Epoxy resin • polyimide, • teflon • ceramics <p><i>Accept any recognisable spelling (phonetic) of the answers above.</i></p> <p style="text-align: right;">(1 x 1)</p>	(1)

Question Number	Answer	Mark
10(b)(i)	<p>Any two of the following:</p> <ul style="list-style-type: none"> • drilling • pick and place • soldering • etching • crimping • polishing/coating/painting/powder coating/plating • compression moulding • forming • fabricating • milling • printing • surface mount technology <p>Do not accept moulding <i>1 mark per response up to 2</i></p> <p><i>Accept any recognisable spelling (phonetic) of the answers above.</i></p> <p style="text-align: right;">(2 x 1)</p>	(2)

Question Number	Answer	Mark
10(b)(ii)	<p>Appropriate explanation including two of the following points:</p> <ul style="list-style-type: none"> • quick method/fast production rate • produces 3-D shape/intricate shapes can be produced • little finishing required • unit costs are low • can be automated • or similar <p>Injection moulding is used as it allows parts such as the outer case to be produced quickly (1) and into a complicated 3D shape (1).</p> <p>After the initial set up costs, the unit cost is low (1) and in some cases it can be easily automated (1). <i>1 x 1 mark low response, or up to 2 for detailed response</i></p> <p style="text-align: right;">(2 x 1)</p>	(2)

Question Number	Answer	Mark
10(c)	<p>An explanation that makes reference to three of the following points:</p> <ul style="list-style-type: none"> • Improved wear resistance • Longer lasting parts such as the outer case • less maintenance/maintenance free • Lighter parts • Easier manufacturing • Better functionality • More variation of products - radio etc • Expanding markets • Smaller components • Miniaturisation of the electronics • Any other appropriate answer <p><i>Up to 3 x 1 mark low responses or up to 3 marks for a detailed response</i></p> <p style="text-align: right;">(3 x 1)</p>	(3)

Question Number	Answer	Mark
11(a)(i)	<p>One application such as:</p> <ul style="list-style-type: none"> • check physical damage • size checks • functional checks • positional and dimensional checks • length of material / surface finish • properties testing • electronic tests • or similar <p><i>Must be within production or assembly</i></p> <p style="text-align: right;">(1 x 1)</p>	(1)

Question Number	Answer	Mark
11(a)(ii)	<p>Description of how such as:</p> <ul style="list-style-type: none"> • check physical damage - by visual inspection (1) and checking against drawing (1) • size checks - by direct measurement or gauging (1) and checking against drawing (1) • functional checks - use test rig (1) and trying the clock (1) • positional and dimensional checks - use of co-ordinate measuring machine (1) and analysing reported data (1) • length of material / surface finish - use of variable quality indicator / probe (1) and comparing with preferred or standard values (1) • use of gauges (1) and inspection equipment / techniques (1) • properties testing - in system testing / hardness testing (1) on surface of table (1) • electronics testing - voltage and current levels (1) correct power consumption (1) • electronic testing - clock accuracy (1) functionality (1) <p><i>Allow follow through up to 1 mark and if no answer in part 11(a)(i) up to 1 mark for a correct answer.</i></p> <p style="text-align: right;">(2 x 1)</p>	(2)

Question Number	Answer	Mark
11(a)(iii)	<p>An explanation that makes reference to three of the following points:</p> <ul style="list-style-type: none"> • safer product to use • confidence in product reliability • consistent product • helps to maintain standards • longer useable life • don't have to buy as often • product reliability • confidence in the company • lower prices • any other appropriate response <p><i>Must relate to the user</i></p> <p style="text-align: right;">(3 x 1)</p>	(3)

Question Number	Answer	Mark
11(b)(i)	<p>One mark for stating the type of computer control</p> <ul style="list-style-type: none"> • CAD • Controlling output • CNC/ Machining centre • CAM • Robot / conveyor system/pick and place • CIM • CIE • Programmable logic controllers PLCs <p>Must be withing production or assembly</p> <p style="text-align: right;">(1 x 1)</p>	(1)

Question Number	Answer	Mark
11(b)(ii)	<p>Two marks for the description</p> <ul style="list-style-type: none"> • Downloads drawings (1) - to machines (1) • Modifies programmes / settings (1) - to alter manufacturing process (1) • Move / rotate / reposition parts (1) - to machining position (1) • Computer controls the positioning of the robot (1) to carry out a difficult manoeuvre (1) <p><i>1 mark for low response or 2 marks for detailed response</i></p> <p><i>If no computer control is stated or an inappropriate answer is given in 11(b)(i) allow follow through up to 1 mark for an appropriate description.</i></p> <p style="text-align: right;">(2 x 1)</p>	(2)

Question Number	Answer	Mark
11(c)	<p>An explanation that makes reference to three of the following points:</p> <ul style="list-style-type: none"> • makes sure current specification is always used during manufacture • safer production methods • product reliability / consistent product • ensures standards are met • lower costs / control of costs / more profit • less scrap / waste / more efficient • avoids faulty parts being assembled • early detection of problems • increased sales • user confidence / less returns • reduced waste • control of manufacturing process • monitoring standards testing / parts • no breaking parts • monitoring component / parts • any other appropriate response <p><i>1 x 1 mark low response, 3 x 1 mark 3 low responses or up to 3 for detailed response</i></p> <p style="text-align: right;">(3 x 1)</p>	(3)

Question Number	Answer	Mark
12(a)(i)	<p>Any two of the following:</p> <ul style="list-style-type: none"> • Analyse market research data in database • Cost the resource requirements for LCD alarm clocks in spreadsheet • Plan marketing campaign using DTP software • Use of internet/website for marketing • Assists with pricing products • Or similar <p><i>1 mark per response up to 2</i></p> <p style="text-align: right;">(2 x 1)</p>	(2)

Question Number	Answer	Mark
12(a)(ii)	<p>One mark for identifying the use One mark for how:</p> <ul style="list-style-type: none"> • Development of labelling (1) and / by electronic tagging protocol (1) • Electronic monitoring (1) of some packaging processes (1) • Use of bar codes (1) to monitor packaging / dispatch of LCD alarm clocks (1) • Use of software (1) to record, log output of LCD alarm clocks (1) • Any other appropriate response <p style="text-align: right;">(1 x 1)+(1 x 1)</p>	(2)

Question Number	Answer	Mark
12(b)	<p>One mark for identifying the benefit One mark for how</p> <ul style="list-style-type: none"> • Establishes a market database (1) shared with the manufacturer (1) • Has accurate costing information (1) shared with the manufacturer (1) / that can be manipulated easily (1) • Gives retailers opportunity to match the market needs (1) with production of LCD alarm clocks (1) • Any other appropriate response <p style="text-align: right;">(1 x 1)+(1 x 1)</p>	(2)

Question Number	Answer	Mark
12(c)	<p>An explanation that makes reference to four of the following points:</p> <ul style="list-style-type: none"> • Fast time to market of latest model of LCD alarm clocks • Use of ICT in market research enables manufacturer to match LCD alarm clocks to market needs • Function / style information available for whole design team • Speed / efficiency of modelling • Modification of ideas • Ease/speed of creating virtual products • On screen design ideas • Speed of decision making by client • Easy access to design data • Working drawings / manufacturing specifications available for whole team • Easy access to manufacturing information in company database • Manufacturing time not wasted • Efficiency of costing materials • Speed of decision making for design team / client • Allows best materials to be used • Appropriate use of database • Modelling ensures characteristics are fit for purpose • Production process are controlled better • Improve aesthetics • Improve packaging design • Any other appropriate response <p style="text-align: right;">(4 x 1)</p>	(4)

Question Number	Answer	Mark
13(a)	<p>A explanation that makes reference to four of the following points to a maximum of four marks:</p> <p>On product cost up to a maximum of three marks</p> <ul style="list-style-type: none"> • Product costs are lower • PLCs controlling processes ensure scrap is not produced • Less manual labour required which is costly • Product cost would be higher if the demand for the LCD alarm clocks is not high • Higher maintenance costs could lead to higher product costs • Any other appropriate response <p>On introduction of new product designs up to a maximum of three marks</p> <ul style="list-style-type: none"> • Sometimes changing the automation will be lengthy • In some cases automation can be arranged to give flexible outputs from a production system • New designs / products may not always lend themselves to automation as well as old designs / products • Any other appropriate response <p style="text-align: right;">(4 x 1)</p>	(4)

Question Number	Answer	Mark
13(b)	<p>An evaluation that makes reference to four of the following points to a maximum of four marks:</p> <p>On the work force up to a maximum of three marks</p> <ul style="list-style-type: none"> • Less jobs • Change in skills • Less employment for unskilled • Change in size • Retraining often required • Different skills needed • Change in work patterns • Increased travel to work / centralisation • Working pattern / 24/7 operation • Job insecurity • Any other appropriate response <p>On the working environment up to a maximum of three marks</p> <ul style="list-style-type: none"> • Safer • Cleaner • Quieter • Healthier • Noise pollution • Any other appropriate response <p style="text-align: right;">(4 x 1)</p>	(4)
Total Marks for section B		(55)
Total marks for paper		(100)

Section A

Question Number	Answer	Mark
1(a)	<ul style="list-style-type: none"> • Metal door lock • Fire extinguisher <p><i>If three boxes ticked max marks = 1 mark. If 4 boxes or more ticked no marks.</i></p> <p style="text-align: right;">(2 x 1)</p>	(2)

Question Number	Answer	Mark
1(b)	<ul style="list-style-type: none"> • Wheel bearing • Brake disc <p><i>If three boxes ticked max marks = 1 mark. If 4 boxes or more ticked no marks.</i></p> <p style="text-align: right;">(2 x 1)</p>	(2)

Question Number	Answer	Mark
2(a)	<ul style="list-style-type: none"> • Rivet (accept any answer that makes reference to a specific rivet) e.g <p>Solid rivet Cup head rivet Dome head rivet Mild steel rivet Rivet Round head rivet Snap head/snap head rivet</p> <p>Do not accept Pop rivet or Blind rivet <i>Accept any recognisable spelling (phonetic) of the answers above.</i></p> <p style="text-align: right;">(1 x 1)</p>	(1)
	<ul style="list-style-type: none"> • Key (accept any answer that makes reference to a specific key) e.g <p>Feather key Round edge key Jib key <i>Accept any recognisable spelling (phonetic) of the answers above.</i></p> <p style="text-align: right;">(1 x 1)</p>	(1)

Question Number	Answer	Mark
2(b)	<p>An answer that makes reference to two of the following points:</p> <ul style="list-style-type: none"> • reduces friction • used on a shaft • helps rotation • gives a smooth action <p>e.g Used to reduce friction (1) between a rotating and a stationary component (1)</p> <p style="text-align: right;">(2 x 1)</p>	(2)
	<p>An answer that makes reference to two of the following points:</p> <ul style="list-style-type: none"> • fixing two pieces of materials together • screwing into a threaded fastener/material/nut • used with a nut • for temporary fixing / joining • used with a washer <p>e.g A mechanical fastener used with a nut (1) to hold components together (1)</p> <p style="text-align: right;">(2 x 1)</p>	(2)

Question Number	Answer	Mark														
3	<p data-bbox="391 324 1157 436"><i>No mark awarded where 2 or more lines are drawn from a term. Lines do not have to be straight but term and key area must be clearly linked.</i></p> <div data-bbox="391 459 1173 1467"> <table border="0"> <thead> <tr> <th data-bbox="391 459 790 504">Term</th> <th data-bbox="790 459 1173 504">Key Area</th> </tr> </thead> <tbody> <tr> <td data-bbox="391 504 638 660">Continuous operation</td> <td data-bbox="790 504 1173 728">Information & Communications Technology (ICT)</td> </tr> <tr> <td data-bbox="391 694 638 828">Computer-aided design (CAD)</td> <td data-bbox="790 728 1173 884">Control technology</td> </tr> <tr> <td data-bbox="391 862 638 963">Databases</td> <td data-bbox="790 884 1173 1041">Control technology</td> </tr> <tr> <td data-bbox="391 1019 638 1120">Polymers</td> <td data-bbox="790 1041 1173 1198">Modern materials</td> </tr> <tr> <td data-bbox="391 1198 638 1288">Automation</td> <td data-bbox="790 1198 1173 1355">Modern materials</td> </tr> <tr> <td data-bbox="391 1366 638 1467">Composites</td> <td data-bbox="790 1355 1173 1512">Modern materials</td> </tr> </tbody> </table> <p data-bbox="1077 1512 1165 1556">(6 x 1)</p> </div>	Term	Key Area	Continuous operation	Information & Communications Technology (ICT)	Computer-aided design (CAD)	Control technology	Databases	Control technology	Polymers	Modern materials	Automation	Modern materials	Composites	Modern materials	(6)
Term	Key Area															
Continuous operation	Information & Communications Technology (ICT)															
Computer-aided design (CAD)	Control technology															
Databases	Control technology															
Polymers	Modern materials															
Automation	Modern materials															
Composites	Modern materials															

Question Number	Answer	Mark
4(a)(i)	<p>Appropriate product such as e.g.</p> <ul style="list-style-type: none"> • motorbike • fire extinguisher • trolley jack • foot pump • bbq • filing cabinet • car • gearbox • toolbox • hydraulic cylinder • lazy tong riveter <p><i>Accept brand name of a specific product.</i></p> <p><i>This list is not exhaustive, accept any product that contains mechanical or automotive componentry or association with the sector.</i></p> <p style="text-align: right;">(1 x 1)</p>	(1)

Question Number	Answer	Mark
4(a)(ii)	<p>Appropriate explanation of what the product does, may include reference to features and function</p> <p>Eg</p> <p style="padding-left: 40px;">Motorbike-To transport you (1) from one place to another (1)</p> <p style="padding-left: 40px;">Fire extinguisher-Used in an emergency (1) to put out fires (1)</p> <p style="padding-left: 40px;">Trolley jack-Used on a car (1) to jack it up (1)</p> <p><i>If product given in 4(a)(i) is not from this sector but is from one of the other engineering manufacturing sectors then allow follow through up to one mark.</i></p> <p><i>No answer to 4(a)(i) no marks for 4(a)(ii)</i></p> <p style="text-align: right;">(2 x 1)</p>	(2)

Question Number	Answer	Mark
4(b)(i)	<ul style="list-style-type: none"> • design (1) marketing (1) production planning (1) materials - supply and control (1) processing/production (1) assembly/finishing (1) packaging/dispatch (1) <p><i>If product given in 4(a)(i) is not from this sector but is from one of the other engineering manufacturing sectors then allow follow through.</i></p> <p><i>No answer to 4(a)(i) no marks for 4(b)(i)</i> <i>Accept a process that is within any of the stages (e.g using CAD, or using CAM) or (e.g. handling customer information) or (e.g. controlling packaging processes) must be appropriate to the product stated in 4(a)(i)</i></p> <p style="text-align: right;">(1 x 1)</p>	(1)

Question Number	Answer	Mark
4(b)(ii)	<p>One mark for identifying advantage One mark for why</p> <p>Appropriate advantage to the manufacturer e.g.</p> <p>Design, marketing, production planning, materials - supply and control, processing/production, assembly/finishing, packaging/dispatch</p> <p>design</p> <ul style="list-style-type: none"> • better designs (1) - can link other information into the process (1), or best designs can be maximised by simulation (1) • faster (1) - many CAD features such as copy, array can be used (1) or if mistakes made they can be quickly rectified (1) <p>marketing</p> <ul style="list-style-type: none"> • accurate information (1) - less mistakes made in capturing data (1) • better/accessible knowledge base (1) - easy data entry/data analysed easy (1) <p>production planning</p> <ul style="list-style-type: none"> • speed (1) - faster than human application (1) <p>materials - supply and control</p> <ul style="list-style-type: none"> • buy best available materials (1) - use of internet (1) • waste control (1) - by monitoring processes and quality control of processes (1) <p>processing/production</p> <p>Answer could relate to the application of CAM and control technology such as:-</p> <ul style="list-style-type: none"> • energy conservation (1) - by control of energy into process (1) • waste control (1) - by monitoring processes and quality control of processes(1) • competitiveness (1) - faster rates of production/application of CAM techniques (1) • product consistency (1) - by control of processes (1) • cost control (1) - by less waste/faulty parts (1) • efficiency (1) - by less waste/faulty parts (1) • speed (1) - faster than human application (1) 	

	<p>assembly/finishing Answer could relate to the application of CAM and control technology such as:-</p> <ul style="list-style-type: none"> • energy conservation (1) - by control of energy into process (1) • waste control (1) - by monitoring processes and quality control of processes(1) • product consistency (1) - by control of processes (1) • cost control (1) - by less waste/faulty parts (1) • efficiency (1) - by less waste/faulty parts (1) speed (1) - faster than human application (1) <p>packaging/dispatch Answer could relate to the application of CAM and control technology such as:-</p> <ul style="list-style-type: none"> • packaging consistency (1) - by control of processes (1) • cost control (1) - by less waste/faulty parts (1) • efficiency (1) - by less waste/faulty parts (1) • speed (1) - faster than human application (1) • energy conservation (1) - by control of energy into process (1) • waste control (1) - by monitoring processes and quality control of processes (1) <p><i>Low response (1) or two low responses (2) or detailed response (2)</i> <i>If the answer in part 4(b)(i) is not a Manufacturing stage allow follow through up to 2 marks.</i></p> <p><i>No answer to 4(b)(i) no marks for 4(b)(ii)</i></p>	<p style="text-align: right;">(1 x 1)+(1 x 1) (2)</p>
--	---	--

Question Number	Answer	Mark
4(c)(i)	<ul style="list-style-type: none"> • polymer / plastic (although plastic is not technically correct accept the term plastic) • adhesive • coating • metal • composite • shape memory alloy • ceramic • Other appropriate modern material - a material currently used for the given application <p><i>Accept brand name of a specific material</i></p> <p><i>If product given in 4(a)(i) is not from this sector but is from one of the other engineering manufacturing sectors then allow follow through.</i></p> <p><i>No answer to 4(a)(i) no marks for 4(c)(i)</i></p> <p style="text-align: right;">(1 x 1)</p>	(1)

Question Number	Answer	Mark
4(c)(ii)	<p>One mark for identifying improvement One mark for how</p> <ul style="list-style-type: none"> • smaller size (1) - miniaturisation (1) • lower weight (1) - better strength to weight ratio (1) • better appearance (1) - smoother/brighter finishes (1) • extends the life-time of product (1) - better wear characteristics (1) • improves wear resistance (1) - harder materials/better surface finish (1) • reduces cost (1) - overall product easier/earlier machine ability (1) <p><i>If answer in part 4(a)(i) is inappropriate but the material given in 4(c)(i) is appropriate allow follow through up to 2 marks. If no answer is given in part 4(a)(i) but the answer to part 4(c)(ii) relates to the material stated in part 4(c)(i) allow follow through up to 1 mark. If no answer or incorrect answer given in part 4(c)(i) no marks awarded for 4(c)(ii).</i></p> <p style="text-align: right;">(1 x 1)+(1 x 1)</p>	(2)

Question Number	Answer	Mark
5(a)	<p>One mark for identifying the benefit One mark for how Answers must relate to manufacturer</p> <ul style="list-style-type: none"> • reduced ordering times (1) - automatic monitoring (1) • improve quality / accuracy (1) - control of processes (1) • reduced wastage (1) - optimise production methods (1) • improved efficiency (1) - faster / quicker throughput (1) • better process control (1) - in process monitoring (1) • reduced labour (1) - automated processes (1) • lower costs (1) - reduced wastage/faster/continuous production (1) • safer processes (1) - less manual input (1) <p><i>Do not accept easier or faster/quicker without explanation.</i> <i>Low response (1) or two low responses (2) or detailed response (2), for each of 3 benefits</i></p> <p style="text-align: right;">(2 x 1) + (2 x 1) + (2 x 1)</p>	(6)

Question Number	Answer	Mark
5(b)	<p>One mark for identifying the reason One mark for how Answers must relate to consumer</p> <ul style="list-style-type: none"> • more consistent products (1) manufactured more accurately (1) • lower purchase price (1) faster production rates (1) • shorter order times (1) flexible methods used/variation in applied methods of production/faster production rates (1) • better quality/accurate product (1) processes controlled better/closer tolerances achieved (1) • customer satisfaction (1) better quality products produced (1) • consistent product (1) processes controlled better/closer tolerances achieved (1) • product guarantee (1) manufacturer has confidence in products produced/more reliable methods used (1) <p><i>Low response (1) or detailed statement (2) or two low responses (2)</i></p> <p style="text-align: right;">(1 x 1)+(1 x 1)</p>	(2)

Question Number	Answer	Mark
6(a)(i)	<p><i>Mark allocation 1 mark for a relevant type</i></p> <ul style="list-style-type: none"> • Mobile phone / infrared / bluetooth • Email / messaging • Internet / wireless / Wi-fi • Video conferencing • Electronic point of sale (EPOS) • EDI • ISDN • Texting • Phone • Walkie talkie • Fax <p><i>Do not accept: TV, CAD, radio, computer / laptop / database</i></p> <p style="text-align: right;">(1 x 1)</p>	(1)

Question Number	Answer	Mark
6(a)(ii)	<p>One mark for identifying the benefit One mark for how</p> <ul style="list-style-type: none"> • Mobile phone - can talk to supplier when needed (1) flexibility / roaming location (1) • Email - can send or receive instructions that are accurate/can get or send written confirmation of instructions (1) immediate permanent record (1) • Internet - can order and check stock immediately/in real time (1) immediate vast access to information (1) • Video conferencing -no travel expenses / less time wasted in travelling (1) but has face to face contact (1) • Electronic point of sale (EPOS) - faster / more accurate control of stock (1) automatic reading of bar codes (1) • EDI - immediate transfer of information / no hard copies needed / less storage space (1) by use of secure on-line facilities (1) • ISDN - more data transferred in parallel (1) faster response rate with supplier through use of technology (1) • Texting - can refer back to what message was given (1) stored record of transaction (1) • Phone - can clarify and confirm without having to re-visit the discussion later (1) immediate two way conversation (1) • Walkie talkie - can clarify and confirm without having to re-visit the discussion later (1) immediate two way conversation / flexibility / roaming location / cost (1) • Fax - can refer back to what message was given (1) stored record of transaction (1) <p>Other benefits may be seen in the light of:</p> <p>Speed, accuracy, JIT, information retrieval, meets consumer demands, quicker, increased sales, reduced stock levels, reduced running costs, reduced lead times, calculation of sales, stock taking quicker/easier, storage space reduced or any other appropriate reason</p> <p><i>Answer must relate to technology given in 6(a)(i)</i></p> <p><i>If part 6(a)(i) is not answered or answered incorrectly, no mark awarded for 6(a)(ii).</i></p> <p style="text-align: right;">(1 x 1)+(1 x 1)</p>	(2)

Question Number	Answer	Mark
6(b)(i)	<p>One mark for identifying the way One mark for how</p> <ul style="list-style-type: none"> • Email can send or receive attachments (1) such as databases or spreadsheets (1) • Internet use in real time (1) can transfer sales information immediately by data entry (1) • Automated distributor use of electronic point of sale (EPOS) (1) can transfer sales data by automatic reading of bar codes (1) • Distributors can use EDI (1) for immediate transfer of sales information by use of secure on-line facilities (1) • Fax can be used to show highlight sales figures only without detail (1) by typing into the messaging system (1) <p><i>Detailed statement required for 2, two low responses (1)</i></p> <p style="text-align: right;">(1 x 1)+(1 x 1)</p>	(2)

Question Number	Answer	Mark
6(b)(ii)	<p>One mark for each point made such as:</p> <p>Email</p> <ul style="list-style-type: none"> • distributor will have permanent record • can allow manufacturer to amend record sent • sends accurate information to respond to • can export information from own systems • limited ICT skills required • low cost <p>Internet</p> <ul style="list-style-type: none"> • doesn't need manual input • information given by the distributor is up to date • can use the internet information to plan marketing campaigns • online ordering • low cost <p>Distributors can use EDI</p> <ul style="list-style-type: none"> • doesn't need manual input • information given by the distributor is up to date • immediate response to sales • more responsive to stock movement • low cost <p>Fax</p> <ul style="list-style-type: none"> • does not give away all sales details to manufacturer • low cost • immediate hard copy • better medium for authorisation • limited ICT skills required <p><i>Do not accept any answers that suggest communications technology is free of charge or is no cost</i></p> <p><i>1 x 1 mark low response, 3 x 1 mark 3 low responses or up to 3 for detailed response</i></p> <p><i>If 6(b)(i) is not answered or is answered incorrectly but the answer to 6(b)(ii) identifies the communications technology; allow follow through up to 2 marks.</i></p> <p style="text-align: right;">(3 x 1)</p>	(3)

Question Number	Answer	Mark
7(a)	<p>One mark for each point made up to 2 marks such as:</p> <ul style="list-style-type: none"> • safer for operators/workers • Can detect production/ process problems • can handle hazardous processes • does not suffer from fatigue • does not make errors relative to safety aspects • more efficient/does not tire • less waste • once set up correctly will continue to produce to a given standard • Can promote multiskilling <p><i>Any other appropriate response.</i> <i>Low responses (1) or detailed statement (2)</i></p> <p style="text-align: right;">(1 x 1)+(1 x 1)</p>	(2)

Question Number	Answer	Mark
7(b)	<p>One mark for each point made up to 2 marks such as:</p> <ul style="list-style-type: none"> • high set up costs • may have high running costs • may have high maintenance requirements • may not have flexibility in product range • may need close computer control to avoid mal-function <p><i>Any other appropriate response.</i> <i>Low responses (1) or detailed statement (2)</i> Do not accept "cost" without explanation</p> <p>Do not accept answers relating to less employees</p> <p style="text-align: right;">(1 x 1)+(1 x 1)</p>	(2)
Total marks for section A		(45)

Section B

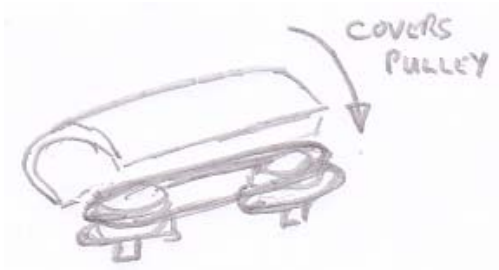
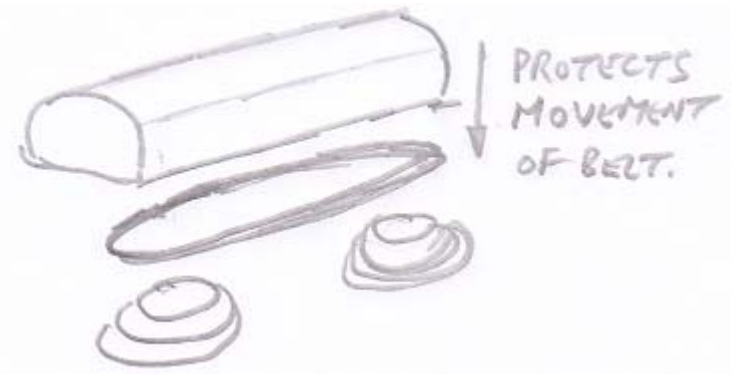
Question Number	Answer	Mark
8(a)	<p>An answer that makes reference to three of the following points:</p> <ul style="list-style-type: none"> • Fits over the pulleys • Fits over the belt • Stops you getting your fingers trapped • Acts as a safety guard • Is a place for the manufacturer to print instructions • Stops pulley system from damaging machine and/or operator if belt fails <p><i>Answer must contain both notes and sketches. Max two marks if only notes or only sketches used.</i></p> <p><i>e.g.</i></p>  <p>or</p>  <p style="text-align: right;">(3 x 1)</p>	(3)

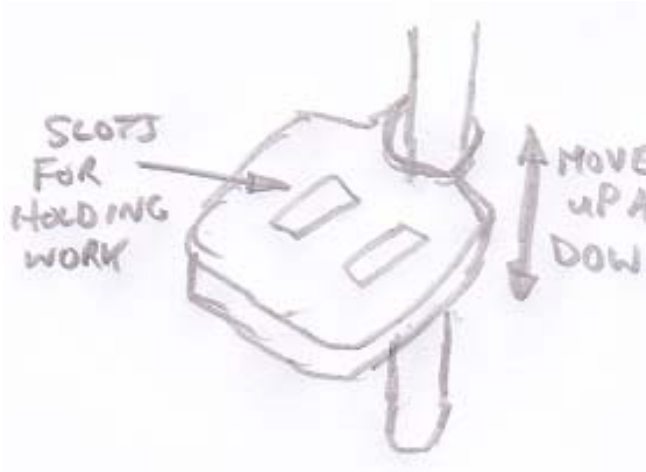
Question Number	Answer	Mark
8(b)	<p>An answer that makes reference to three of the following points:</p> <ul style="list-style-type: none"> • Holds work / vice • Has slots to enable fixings to be used • Can be moved up and down to allow work to be drilled • Ensures drill will make hole at 90 degrees • Can be moved from side to side so that clamped work can be positioned correctly under tool <p><i>Answer must contain both notes and sketches. Max two marks if only notes or only sketches used.</i></p> <p><i>e.g.</i></p>  <p>or</p>  <p style="text-align: right;">(3 x 1)</p>	(3)

Question Number	Answer	Mark
9(a)(i)	<ul style="list-style-type: none"> • Marketing • Production Planning or Planning <p>Do not accept production on its own <i>Must be in this order</i> Accept any recognisable spelling (phonetic) of the answers above</p> <p style="text-align: right;">(1 x 1)+(1 x 1)</p>	(2)

Question Number	Answer	Mark
9(a)(ii)	<ul style="list-style-type: none"> • Production/processing • Stage 5 / stage five • 5 / five <p><i>Accept any recognisable spelling (phonetic) of the answers above.</i></p> <p style="text-align: right;">(1 x 1)</p>	(1)

Question Number	Answer	Mark
9(b)(i)	<p>Appropriate descriptions including three of the following points:</p> <ul style="list-style-type: none"> • Fitting of parts together (any mention of any part being fitting onto the drill, such as - fitting the pulleys on the drive shaft) • Completing the assembly or sub-assembly of the drill • Parts are fitted/assembled in the correct order • Where the wiring is done • Drill is run to see if it works • Any other appropriate response <p>The stage where the bench pillar drill is assembled (1) and the individual parts are fitted in the correct order (1). It is where the final wiring is done (1) and the drill is checked to see if it runs OK (1). Up to 3 marks</p> <p><i>1 x 1 mark low response, 3 x 1 mark 3 low responses or up to 3 for detailed response</i></p> <p style="text-align: right;">(3 x 1)</p>	(3)

Question Number	Answer	Mark
9(b)(ii)	<p>Appropriate descriptions including three of the following points:</p> <ul style="list-style-type: none"> • Application of protective packaging • Assembling orders • Application of codes, dates, tech info • Picking orders • Assembling loads • Packing into outer boxes • Making records • Application of labels to boxes • Sending to client • Final visual checks • Collation of multiple items • Any other appropriate response <p>The stage where the finished bench pillar drills have any labels added (1), and are prepared for shipment (1) by the use of any protective materials (1) such as foam packaging or grease to prevent corrosion (1). The packaged drill is loaded onto the preferred method of dispatch and carrier (1) to be sent to the customer or distributor (1). Up to 3 marks</p> <p><i>1 x 1 mark low response, 3 x 1 mark 3 low responses or up to 3 for detailed response</i></p> <p style="text-align: right;">(3 x 1)</p>	(3)

Question Number	Answer	Mark
10(a)(i)	<p>Specific materials to make the plunge handle knob</p> <ul style="list-style-type: none"> • Thermosetting polymer • Thermosetting plastic/polymer/thermoset • Urea formaldehyde/UF • Phenol formaldehyde/PF • Bakelite • Aluminium/ Aluminium alloy • Thermoset <p><i>Accept any recognisable spelling (phonetic) of the answers above.</i></p> <p><i>Do not accept 'Plastic' or 'Polymer' or 'Alloy' on its own</i></p> <p style="text-align: right;">(1 x 1)</p>	(1)

Question Number	Answer	Mark
10(a)(ii)	<p>Specific materials to make the base</p> <ul style="list-style-type: none"> • Cast iron • Ferrous alloy • Steel alloy • Wrought iron <p><i>Accept any recognisable spelling (phonetic) of the answers above.</i></p> <p style="text-align: right;">(1 x 1)</p>	(1)

Question Number	Answer	Mark
10(a)(iii)	<p>Specific materials to make the guard</p> <ul style="list-style-type: none"> • Polycarbonate • Polycarb • HIPS • Acrylic <p><i>Accept any recognisable spelling (phonetic) of the answers above.</i></p> <p style="text-align: right;">(1 x 1)</p>	(1)

Question Number	Answer	Mark
10(b)(i)	<p>Any two of the following:</p> <ul style="list-style-type: none"> • Casting/ sand casting • Casting/ die casting • drilling • turning • milling • grinding • boring • hardening/surface hardening • annealing/normalising • etching • soldering/crimping • polishing/coating/painting/powder coating/plating • compression moulding <p>Do not accept moulding <i>1 mark per response up to 2</i> <i>Accept any recognisable spelling (phonetic) of the answers above</i></p> <p><i>If casting is rewarded as a correct answer do not reward sand casting</i></p> <p style="text-align: right;">(2 x 1)</p>	(2)

Question Number	Answer	Mark
10(b)(ii)	<p>Appropriate explanation including two of the following points:</p> <ul style="list-style-type: none"> • quick method/fast production rate • produces 3-D shape/intricate shapes can be produced • little finishing required • unit costs are low • can be automated • or similar <p>Injection moulding is used as it allows parts such as the pulley guard to be produced quickly (1) and into a complicated 3D shape (1).</p> <p>After the initial set up costs, the unit cost is low (1) and in some cases it can be easily automated (1).</p> <p><i>1 x 1 mark low response, or up to 2 for detailed response</i></p> <p style="text-align: right;">(2 x 1)</p>	(2)

Question Number	Answer	Mark
10(c)	<p>An explanation that makes reference to three of the following points:</p> <ul style="list-style-type: none"> • Improved wear resistance • Longer lasting parts such as the chuck • Moving products needed less maintenance • Lighter guards and other parts • Easier manufacturing • Better functionality • More variation of products • Expanding markets (DIY, School) i.e. smaller drills doing similar work to older models etc • Smaller components • Miniaturisation of the electronic controls • Improved aesthetics • Reduced cost • Environmental improvements such as recycling thermoplastics • Any other appropriate answer <p><i>Up to 3 x 1 mark low responses or up to 3 marks for a detailed response</i></p> <p style="text-align: right;">(3 x 1)</p>	(3)

Question Number	Answer	Mark
11(a)(i)	<p>One application such as:</p> <ul style="list-style-type: none"> • check physical damage • size checks • functional checks • positional and dimensional checks • length of material / surface finish • holes drilled / slots milled in base / table • properties testing • or similar <p><i>Must be within production or assembly</i></p> <p style="text-align: right;">(1 x 1)</p>	(1)

Question Number	Answer	Mark
11(a)(ii)	<p>Description of how such as:</p> <ul style="list-style-type: none"> • check physical damage - by visual inspection (1) and checking against drawing (1) • size checks - by direct measurement or gauging (1) and checking against drawing (1) • functional checks - use test rig (1) and trying the drill out (1) • positional and dimensional checks - use of co-ordinate measuring machine (1) and analysing reported data (1) • length of material / surface finish - use of variable quality indicator / probe (1) and comparing with preferred or standard values (1) • holes drilled / slots milled in base / table - use of gauges (1) and inspection equipment / techniques (1) • properties testing - in system testing / hardness testing (1) on surface of table (1) • ultra sound testing (1) - for cracks etc (1) <p><i>Allow follow through up to 1 mark and if no answer in part 11(a)(i) up to 1 mark for a correct answer.</i></p> <p style="text-align: right;">(2 x 1)</p>	(2)

Question Number	Answer	Mark
11(a)(iii)	<p>An explanation that makes reference to three of the following points:</p> <ul style="list-style-type: none"> • safer product to use • confidence in product reliability • consistent product • helps to maintain standards • longer useable life • don't have to buy as often • product reliability • confidence in the company • lower prices • any other appropriate response <p><i>Must relate to the user</i></p> <p style="text-align: right;">(3 x 1)</p>	(3)

Question Number	Answer	Mark
11(b)(i)	<p>One mark for stating the type of computer control</p> <ul style="list-style-type: none"> • CAD • Controlling output • CNC/ Machining centre • CAM • Robot / conveyor system • CIM • CIE • Programmable logic controllers PLCs <p>Must be within production or assembly</p> <p style="text-align: right;">(1 x 1)</p>	(1)

Question Number	Answer	Mark
11(b)(ii)	<p>Two marks for the description</p> <ul style="list-style-type: none"> • Downloads drawings (1) - to machines (1) • Modifies programmes / settings (1) - to alter manufacturing process (1) • Move / rotate / reposition parts (1) - to machining position (1) • Computer controls the positioning of the robot (1) to carry out a difficult manoeuvre (1) <p><i>1 mark for low response or 2 marks for detailed response</i> <i>If no computer control is stated or an inappropriate answer is given in 11(b)(i) allow follow through up to 1 mark for an appropriate description.</i></p> <p style="text-align: right;">(2 x 1)</p>	(2)

Question Number	Answer	Mark
11(c)	<p>An explanation that makes reference to three of the following points:</p> <ul style="list-style-type: none"> • makes sure current specification is always used during manufacture • safer production methods • product reliability / consistent product • ensures standards are met • lower costs / control of costs / more profit • less scrap / waste / more efficient • avoids faulty parts being assembled • early detection of problems • increased sales • user confidence / less returns • reduced waste • control of manufacturing process • monitoring standards testing / parts • no breaking parts • monitoring component / parts • any other appropriate response <p><i>1 x 1 mark low response, 3 x 1 mark 3 low responses or up to 3 for detailed response</i></p> <p style="text-align: right;">(3 x 1)</p>	(3)

Question Number	Answer	Mark
12(a)(i)	<p>Any two of the following:</p> <ul style="list-style-type: none"> • Analyse market research data in database • Cost the resource requirements for bench pillar drills in spreadsheet • Plan marketing campaign using DTP software • Use of internet/website for marketing • Assists with pricing products • Or similar <p><i>1 mark per response up to 2</i></p> <p style="text-align: right;">(2 x 1)</p>	(2)

Question Number	Answer	Mark
12(a)(ii)	<p>One mark for identifying the use One mark for how:</p> <ul style="list-style-type: none"> • Development of labelling (1) and / by electronic tagging protocol (1) • Electronic monitoring (1) of some packaging processes (1) • Use of bar codes (1) to monitor packaging / dispatch of bench pillar drills (1) • Use of software (1) to record, log output of bench pillar drills (1) • Any other appropriate response <p style="text-align: right;">(1 x 1)+(1 x 1)</p>	(2)

Question Number	Answer	Mark
12(b)	<p>One mark for identifying the benefit One mark for how</p> <ul style="list-style-type: none"> Establishes a market database (1) shared with the manufacturer (1) Has accurate costing information (1) shared with the manufacturer (1) / that can be manipulated easily (1) Gives distributors opportunity to match the market needs (1) with production of bench pillar drills (1) Any other appropriate response <p style="text-align: right;">(1 x 1)+(1 x 1)</p>	(2)

Question Number	Answer	Mark
12(c)	<p>An explanation that makes reference to four of the following points:</p> <ul style="list-style-type: none"> Fast time to market of latest model of bench pillar drills Use of ICT in market research enables manufacturer to match bench pillar drills to market needs Function / style information available for whole design team Speed / efficiency of modelling Modification of ideas Ease/speed of creating virtual products On screen design ideas Speed of decision making by client Easy access to design data Working drawings / manufacturing specifications available for whole team Easy access to manufacturing information in company database Manufacturing time not wasted Efficiency of costing materials Speed of decision making for design team / client Allows best materials to be used Appropriate use of database Modelling ensures characteristics are fit for purpose Production process are controlled better Improved aesthetics Any other appropriate responses <p style="text-align: right;">(4 x 1)</p>	(4)

Question Number	Answer	Mark
13(a)	<p>A explanation that makes reference to four of the following points to a maximum of four marks:</p> <p>On product cost up to a maximum of three marks</p> <ul style="list-style-type: none"> • Product costs are lower • PLCs controlling processes ensure scrap is not produced • Less manual labour required which is costly • Product cost would be higher if the demand for the bench pillar drill is not high • Higher maintenance costs could lead to higher product costs • Any other appropriate response <p>On introduction of new product designs up to a maximum of three marks</p> <ul style="list-style-type: none"> • Sometimes changing the automation will be lengthy • In some cases automation can be arranged to give flexible outputs from a production system • New designs / products may not always lend themselves to automation as well as old designs / products • Any other appropriate response <p style="text-align: right;">(4 x 1)</p>	(4)

Question Number	Answer	Mark
13(b)	<p>An evaluation that makes reference to four of the following points to a maximum of four marks:</p> <p>On the work force up to a maximum of three marks</p> <ul style="list-style-type: none"> • Less jobs • Change in skills • Less employment for unskilled • Change in size • Retraining often required • Different skills needed • Change in work patterns • Increased travel to work / centralisation • Working pattern / 24/7 operation • Job insecurity • Any other appropriate response <p>On the working environment up to a maximum of three marks</p> <ul style="list-style-type: none"> • Safer • Cleaner • Quieter • Healthier • Noise pollution • Any other appropriate response <p style="text-align: right;">(4 x 1)</p>	(4)
Total Marks for section B		(55)
Total marks for paper		(100)

Further copies of this publication are available from
Edexcel Publications, Adamsway, Mansfield, Notts, NG18 4FN

Telephone 01623 467467
Fax 01623 450481

For more information on Edexcel qualifications, please visit www.edexcel.com/qualifications

Edexcel Limited. Registered in England and Wales no.4496750
Registered office: One90 High Holborn, London, WC1V 7BH