

Candidate Name	Centre Number	Candidate Number

WELSH JOINT EDUCATION COMMITTEE
General Certificate of Secondary Education



CYD-BWYLLGOR ADDYSG CYMRU
Tystysgrif Gyffredinol Addysg Uwchradd

174/01

HOME ECONOMICS (TEXTILES)

PAPER 1

Foundation Tier – Grades G to C

A.M. WEDNESDAY, 21 June 2006

(1 hour 30 minutes)

Examiner only

TOTAL MARK	
-----------------------	--

ADDITIONAL MATERIALS

Coloured pens/pencils.

INSTRUCTIONS TO CANDIDATES

Write your name, centre number and candidate number in the spaces at the top of this page.

Answer **all** questions.

Write your answers in the spaces provided in this booklet. Where the space is not sufficient for your answer, continue the answer at the back of the book, taking care to number the continuation correctly.

INFORMATION FOR CANDIDATES

The number of marks is given in brackets at the end of each question or part-question.

No certificate will be awarded to a candidate detected in any unfair practice during the examination.

Answer **all** questions.

1. **Underline** the odd one out in the following lists. [3]

(a) Backstitch, Tacking, French seam, French knots.

(b) Gathering, Pleats, Darts, Binding.

(c) Facing, Pinking, Zig-zag stitch, Overcasting.

2. (a) Identify **each** piece of equipment and explain how it is used when working with textiles. [4]

(i)



Item

Purpose

.....

.....

(ii)



Item

Purpose

.....

.....

(b) Name **one** other large item of equipment which may be used with textiles and explain its use. [2]

Equipment

Use

.....

.....

(c) Identify the label below and explain its meaning. [2]



Label

Meaning

.....

.....

3. The diagram show examples of natural, regenerated and synthetic fibres. Some examples are missing.

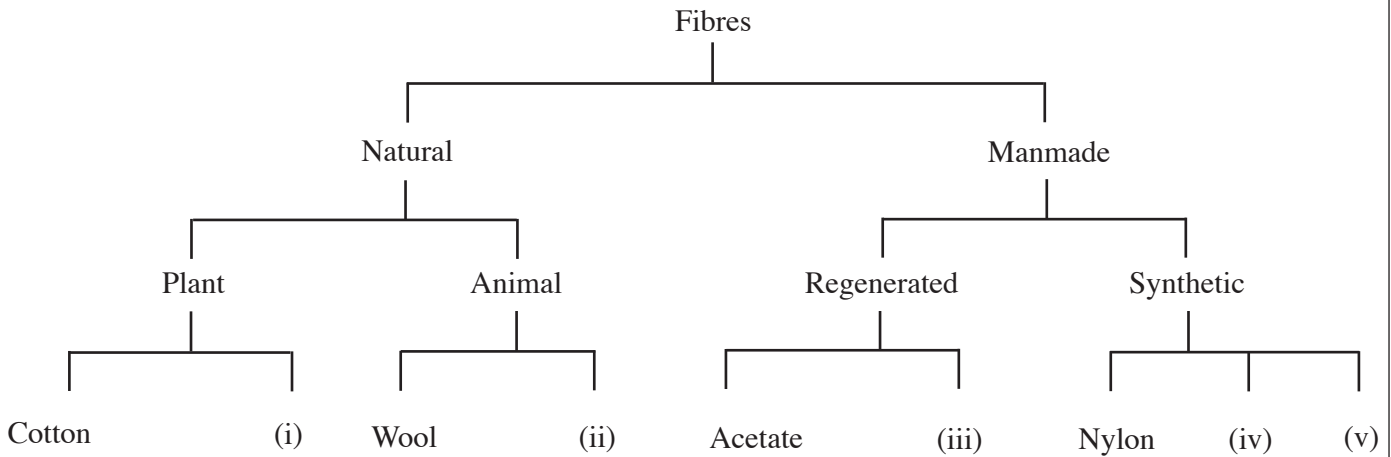

- (a) In the spaces, write the names of the missing fibres to complete the diagram. [5]

- (i)
- (ii)
- (iii)
- (iv)
- (v)

- (b) Which materials carry the following symbols? [3]



- (i) Name

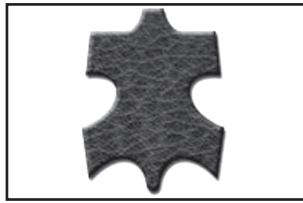

(ii) Name



(iii) Name

(c) Natural and Synthetic fibres are sometimes blended together to make fabrics. Suggest **one** advantage of fabric made from **each** of the following blends. [3]
(A different answer should be given for each.)

(i) Polyester and Cotton

Advantage:
.....
.....

(ii) Wool and Nylon

Advantage:
.....
.....

(iii) Nylon and Lycra

Advantage:
.....
.....

4. Study the diagram and answer the questions.

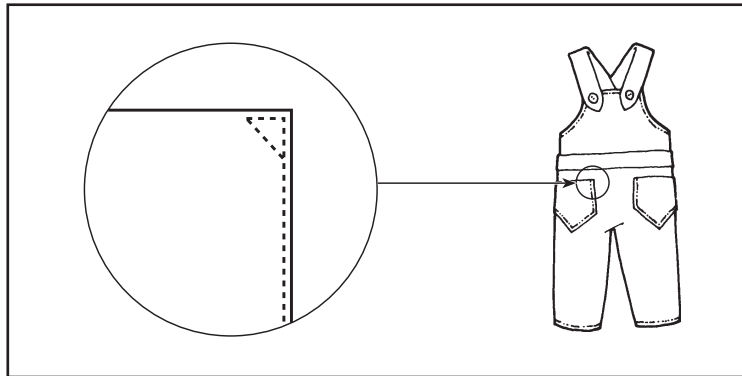

(a) Name the type of pocket illustrated. [1]

.....

(b) Suggest **one** other garment and **one** textile item for the home where this pocket might be used. [2]

Garment

Item for the home

(c) Give **one** reason why the corners of the pocket have been stitched diagonally. [1]

.....

.....

(d) Pockets are often decorated.
Name **two** decorative techniques that could be used on the front pocket of the child's dungarees. [2]

(i)

.....

(ii)

.....

- (e) Explain, with the aid of diagrams, how you would carry out one of your chosen decorative techniques. [4]

Dotted lines for writing and diagrams.

5. You have bought a new pair of jeans. The first time you wear them a tear develops along the inside seam.



- (a) (i) Name the Act that protects the consumer in this situation. [1]

.....

- (ii) Identify the **three** main points of the Act. [3]

.....
.....
.....
.....
.....
.....

- (b) Describe the action you would take after the tear occurred. [3]

.....
.....
.....
.....
.....

- (c) Name **one** other Act that protects the customer. [1]

.....

(d) Jeans are a popular fashion item, worn by all ages.
They can be purchased from:

- (i) High Street Stores;
- (ii) Market Stalls;
- (iii) Mail Order Catalogues.

Discuss these sources.

[6]

(i)

.....

.....

.....

.....

.....

(ii)

.....

.....

.....

.....

.....

(iii)

.....

.....

.....

.....

.....

6. Quilted body warmers (gilets) are currently in style.



(a) What do you understand by the term quilting? [2]

.....

.....

.....

(b) Explain why woven nylon is suitable for the outer layer of this garment. [2]

.....

.....

.....

(c) Explain why woven cotton is suitable for the inner layer of a body warmer. [2]

.....

.....

.....

(d) Explain why polyester wadding is used in the construction of the gilet. [2]

.....

.....

.....

(e) Gilets and body warmers feature in much of today's fashion.
Discuss this statement in relation to current teenage fashion trends.

[6]

.....

.....

.....

.....

.....

.....

.....

.....

.....

.....

.....

.....

.....

.....

.....

.....

.....

.....

.....

.....

A series of horizontal dotted lines for writing, spanning the width of the page.

