



General Certificate of Secondary Education
June 2015

General Studies

47602/1

Unit 2

Monday 15 June 2015 1.30 pm to 3.30 pm

For this paper you must have:

- an objective test answer sheet for Section A
 - a question paper/answer book for Sections B and C (enclosed).
- You may use a calculator.

Time allowed

- 2 hours (for Sections A, B and C)

Instructions

- Use black ink or black ball-point pen.

Section A

- Answer **all** questions.
- For each question there are four responses. When you have selected the response which you think is the best answer to a question, mark this response on your answer sheet.
- Mark all responses as instructed on your answer sheet. If you wish to change your answer to a question, follow the instructions on your answer sheet.
- Do all rough work in this book, **not** on your answer sheet.

Section B and Section C

- Answer **all** questions in Section B and **one** question in Section C.
- You must answer the questions in Section B and Section C in the spaces provided in the enclosed question paper/answer book. Do not write outside the box around each page or on blank pages.
- At the end of the examination make sure you hand in **both** your Section A answer sheet **and** your Section B and C question paper/answer book.

Information

- The maximum mark for this unit is 85.
(There are 30 marks for Section A, 25 marks for Section B and 30 marks for Section C.)
- In Sections B and C you will be assessed for Quality of Written Communication.

Advice

- You are advised to spend up to 40 minutes on Section A and up to 1 hour 20 minutes on Sections B and C.

Section A

Each of Questions **A1** to **A30** is followed by four responses, **A**, **B**, **C** and **D**. For each question, select the best response and mark its letter on the answer sheet.

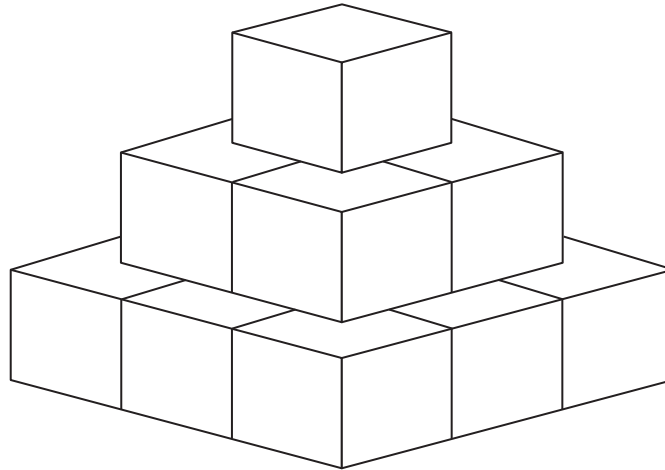
Questions A1 and A2

A1 The diagram shows a climbing area in a children's playground. It is a solid pyramid of white cubes. It is cemented to the ground. If the outer surface of the pyramid is painted red, how many cubes will stay completely white?

- A** 1
- B** 2
- C** 3
- D** 4

A2 How many will have some red paint on 3 sides only?

- A** 4
- B** 8
- C** 9
- D** 12

Questions A3 and A4

A3 In the following sentence the speech marks are missing.

Have you anything to say to me? he asked. Go away! shouted the girl, trying to shut the door.

The correct punctuation for this sentence is:

- A** "Have you anything to say to me?" he asked. "Go away!" shouted the girl, trying to shut the door.
- B** "Have you anything to say to me"? he asked. "Go away!" shouted the girl, trying to shut the door.
- C** "Have you anything to say to me?" he asked. "Go away"! shouted the girl, trying to shut the door.
- D** "Have you anything to say to me"? he asked. "Go away"! shouted the girl, trying to shut the door.

A4 Homophones are words that sound the same but have different spellings and meanings.

Jacob, Isaac and _____ grandfather went for a walk. As they walked slowly up the street Jacob shouted "Look over _____! It's Mrs Jones with Alice and _____ dog." "_____ walking towards us," exclaimed Isaac worriedly.

The correct order for the homophones **there**, **their** and **they're** needed to complete this passage is

- A** there, their, there and they're.
- B** their, there, they're and their.
- C** their, there, their and they're.
- D** they're, their, they're and there.

Turn over for the next question

Turn over ►

Questions A5 and A6

'Your life must now run the course that's been set for it.'

Kazuo Ishiguro

A5 The above quotation reflects a belief in

- A** the supernatural.
- B** personal freedom.
- C** God.
- D** fate.

'I have noticed even people who claim everything is predestined, and that we can do nothing to change it, look before they cross the road.'

Stephen Hawking

A6 Hawking is suggesting that some people

- A** say they have one view and always follow it.
- B** tend to be negative about everything.
- C** believe one thing and then do another.
- D** believe they can change the future for everyone.

Questions A7 and A8**TV company accused of peddling “propaganda” for the monarchy**

A producer for a TV documentary called ‘The Queen’s Diamond Jubilee Song’ told a journalist in Australia that the country’s former Prime Minister, Julia Gillard, would not be suitable for interview because “she is pro-republican” and would not fit the film’s “positive angle”.

The producer added “We are not interested in hearing a personal bad word against The Queen.”

The exchanges were contained in two emails leaked to the anti-monarchy group Republic, which accused the TV company of “censorship”.

A7 According to the article, the TV company has been criticised for

- A** emailing an Australian journalist.
- B** producing a biased documentary about The Queen.
- C** being positive about The Queen.
- D** being an anti-monarchy group.

A8 All of the following are correct definitions of ‘propaganda’ **except**

- A** a controlled system that gives balanced viewpoints.
- B** tries to influence people’s emotions and opinions.
- C** promotion of a particular set of political beliefs.
- D** very persuasive messages that can be seen as positive or negative.

Turn over for the next question

Turn over ►

Questions A9 and A10

The United Nations recognises the family as the basic unit of society. Over the past 50 years the following changes to family structures have taken place:

- Smaller-sized households
- Delayed marriage and childbearing
- Increased divorce rates and single parenthood
- The phenomenon of demographic ageing
- The impact of globalisation.

All these social changes have had an impact on the capacities of families to perform such functions as the socialisation of children and caring for their younger and older members.

A9 The United Nations suggests that

- A** the need for a family has disappeared.
- B** families have changed the way they operate.
- C** ageing leads to globalisation.
- D** parents are now younger when they marry.

A10 The information given at the top of the page about changes to the family structure suggests that it is now

- A** easier to care for children but more difficult to care for older people.
- B** harder to care for children but easier to care for older people.
- C** more difficult to care for children and more difficult to care for older people.
- D** easier to care for children and easier to care for older people.

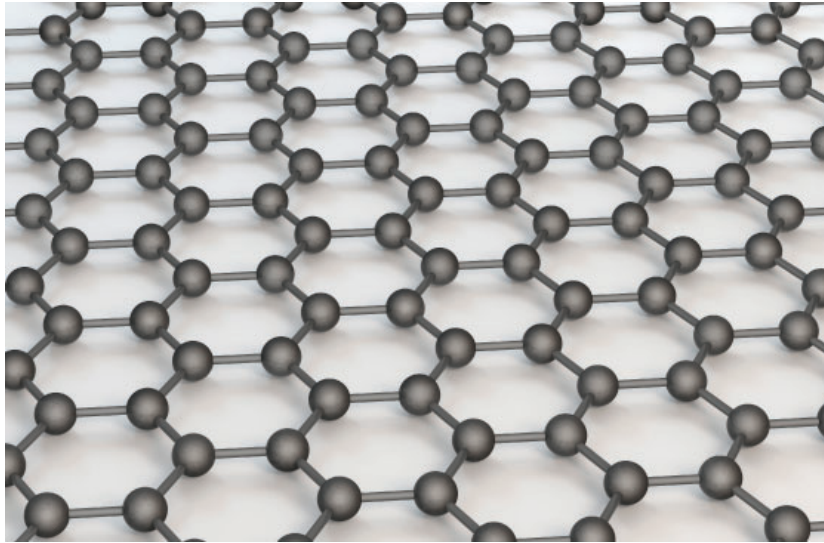
Questions A11 and A12

A11 The above image shows carbon atoms arranged to form the unique structure of graphene. From the image it is possible to conclude that

- A** graphene is only one atom thick.
- B** many things can be made from graphene.
- C** graphene is a very dense material.
- D** each carbon atom is bonded to four others.

A12 Here are some facts about graphene:

- It is the best electrical conductor ever discovered.
- It is the best conductor of heat that we know of.
- It is transparent.
- It can absorb light from the full spectrum and convert it into electricity.

Which of these products could benefit from the use of graphene?

- 1** television screens
- 2** electrical circuits
- 3** fire retardants
- 4** photo-voltaic cells for solar panels

Answer

- A** 1 and 3 only.
- B** 2 and 4 only.
- C** 1, 2 and 4 only.
- D** all of the above.

Turn over ►

Questions A13 and A14

The Principle of Moments states that 'if an object is balanced, the sum of the clockwise moments about a pivot is equal to the sum of the anti-clockwise moments about the same point'.

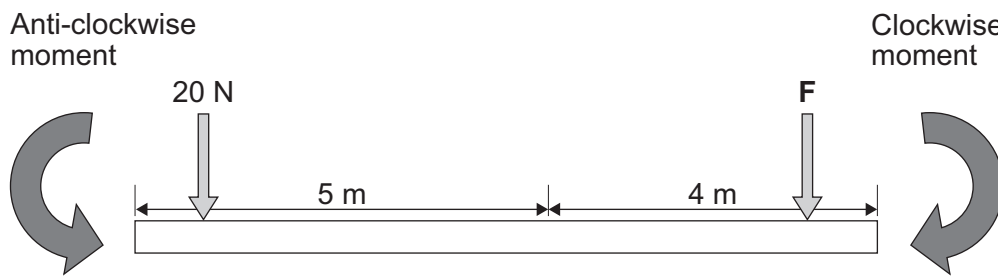

Anti-clockwise moment = $20\text{N} \times 5\text{m} = 100\text{Nm}$

A13 The value for force **F** is:

- A** 15N
- B** 25N
- C** 35N
- D** 50N

Forces are used when we turn something round, eg when we turn on a tap or open a door.

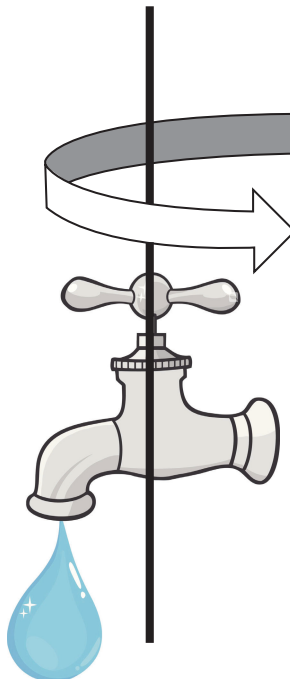

A14 What term is used to describe the central turning point around which the force acts?

- A** Yoke
- B** Clamp
- C** Bracket
- D** Pivot

Questions A15 and A16

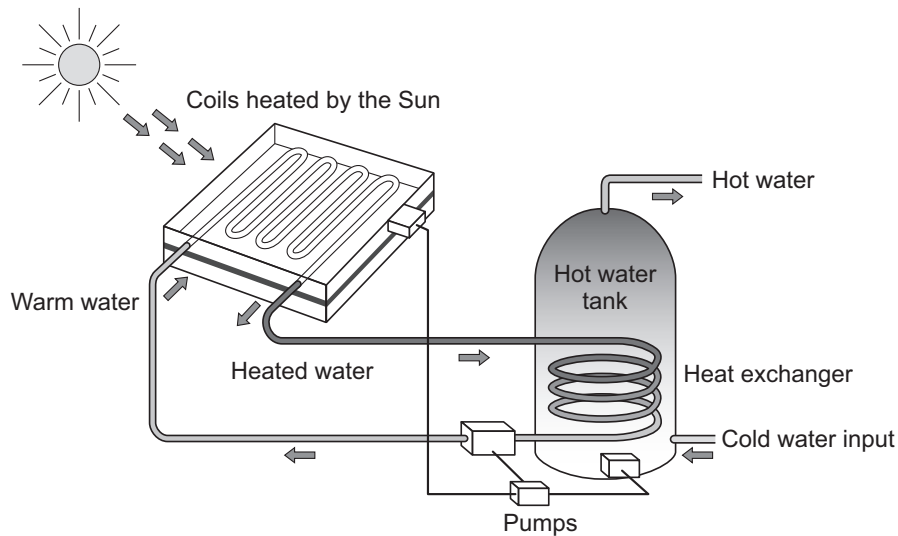

- A15** This is a diagram of a simple solar heating system. The job of the heat exchanger is to
- A** replace the hot with cold water.
 - B** move the water around the system.
 - C** use cold water to cool the water in the tank.
 - D** use the heated water to heat the cold water in the tank.

In low income countries, aid agencies want to encourage people to use solar power. An important development is the solar oven.

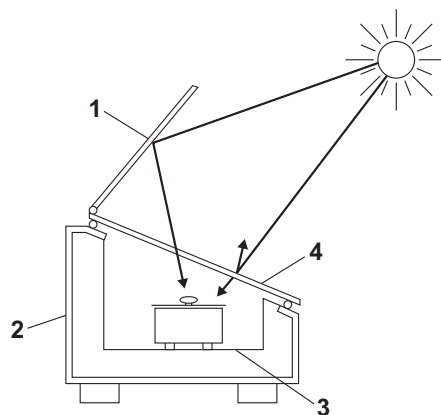

- A16** In order for the solar oven to work most efficiently, the parts labelled are most likely to be
- A** 1. Foil-lined lid 2. Foil-lined box 3. Black inner base 4. Glass cover
 - B** 1. Lid made from glass 2. Cotton-lined box 3. Black inner base 4. Glass cover
 - C** 1. Empty frame 2. Brick-lined box 3. Brick inner base 4. Plastic cover
 - D** 1. Wooden lid 2. Plastic box 3. White base 4. Wire mesh cover.

Turn over ►

Questions A17 and A18



- A17** In the 16th century a traveller set out from Lincoln to London, a journey of 140 miles. He left at 8 am on Monday. If he travelled at an average speed of 4 miles an hour between 8 am and 6 pm each day he would arrive in London at
- A** 4 pm on Wednesday.
 - B** 1 pm on Thursday.
 - C** 4 pm on Thursday.
 - D** 10 am on Friday.



- A18** In the 21st century, a person can leave Lincoln on a train at 8 am and arrive in London at 10.45 am. The journey is 140 miles. What is the average speed of the journey in miles per hour to the nearest whole number?
- A** 46 mph
 - B** 51 mph
 - C** 57 mph
 - D** 68 mph

Questions A19 and A20

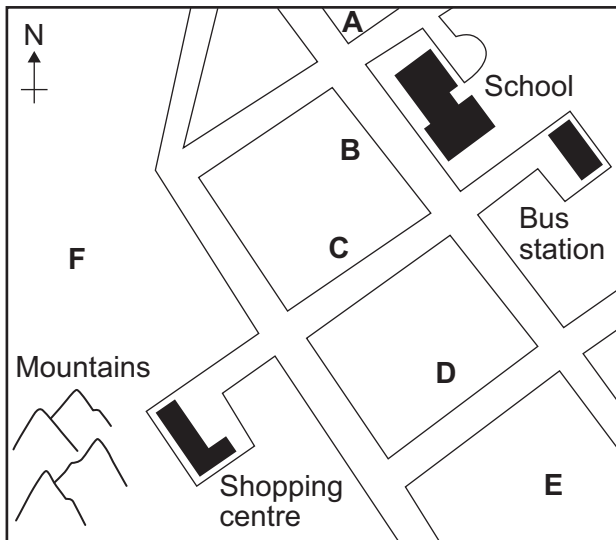

There is a restaurant opposite the school to the west.

There is a factory to the South-East.

There is a train station in the centre, near both the bus station and the shopping centre.

There is a river to the West, flowing from the mountains towards the North.

There is a park to the South-East, between the factory and the train station.

There is a farm to the North, near the school.

A19 Letter **D** on the map indicates

- A** the factory.
- B** the park.
- C** the restaurant.
- D** the river.

A20 If you wanted to go directly from the bus station to the shopping centre, in which direction would you be walking?

- A** North-East
- B** North-West
- C** South-West
- D** South-East

Turn over for the next question

Turn over ►

Questions A21 and A22



A21 The above map is designed for use in

- A telecommunications.
- B energy planning.
- C recreation and tourism.
- D studying voting patterns.

A22 It can be deduced from the map that Ebor is an abbreviation of the Roman name for

- A Brecon.
- B Oxford.
- C Staffordshire.
- D York.

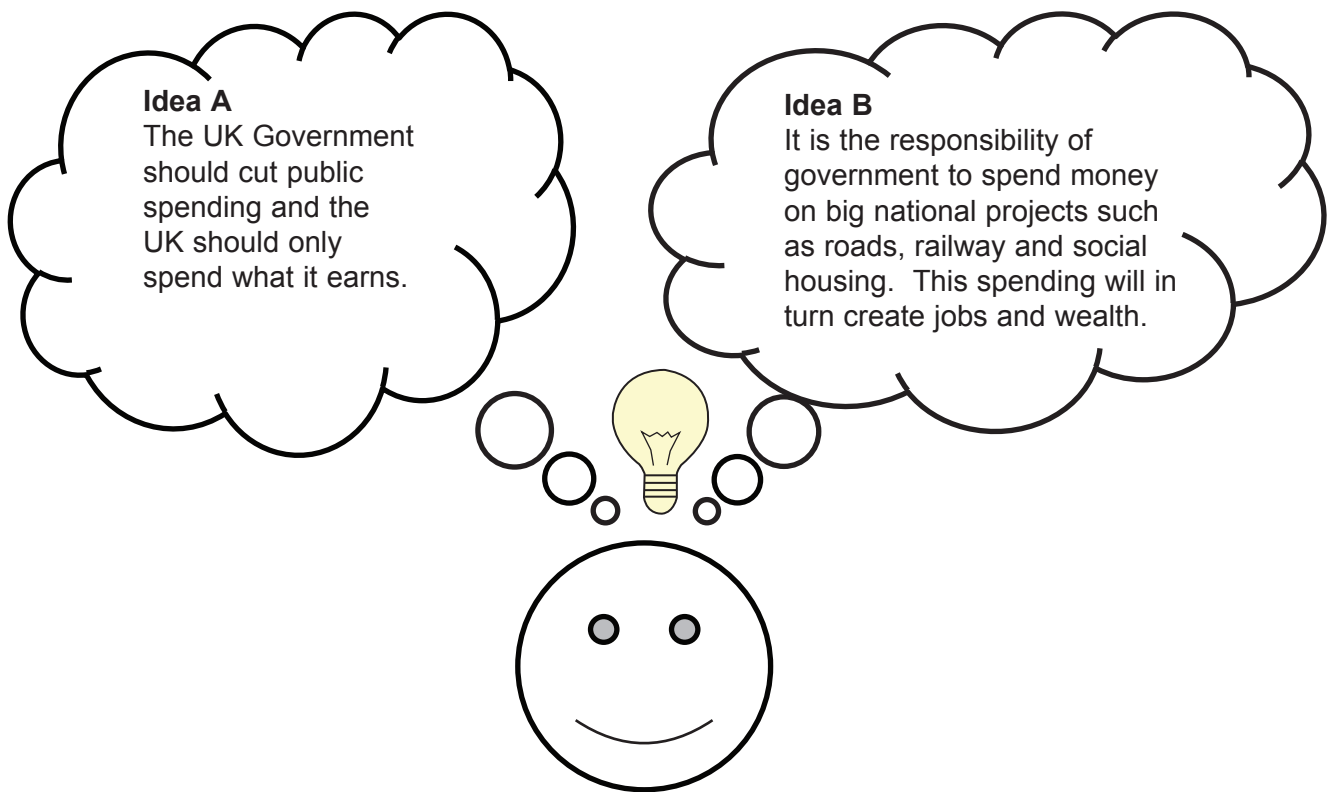
Questions A23 and A24

A23 A clear benefit to the UK of **Idea A** would be

- A** public spending would be cut and many people would have to find new jobs.
- B** public services would be more powerful and employ more people.
- C** the UK would not need to trade with other countries.
- D** the government would have to borrow less money.

A24 Possible effects of **Idea B** include

- 1** increased government spending.
- 2** reduced government spending.
- 3** an increase in tax receipts.
- 4** a reduction in benefit payments.

Answer

- A** if only **1** and **2** are correct.
- B** if only **1**, **3** and **4** are correct.
- C** if only **2** and **3** are correct.
- D** if only **3** and **4** are correct.

Turn over ►

Questions A25 and A26

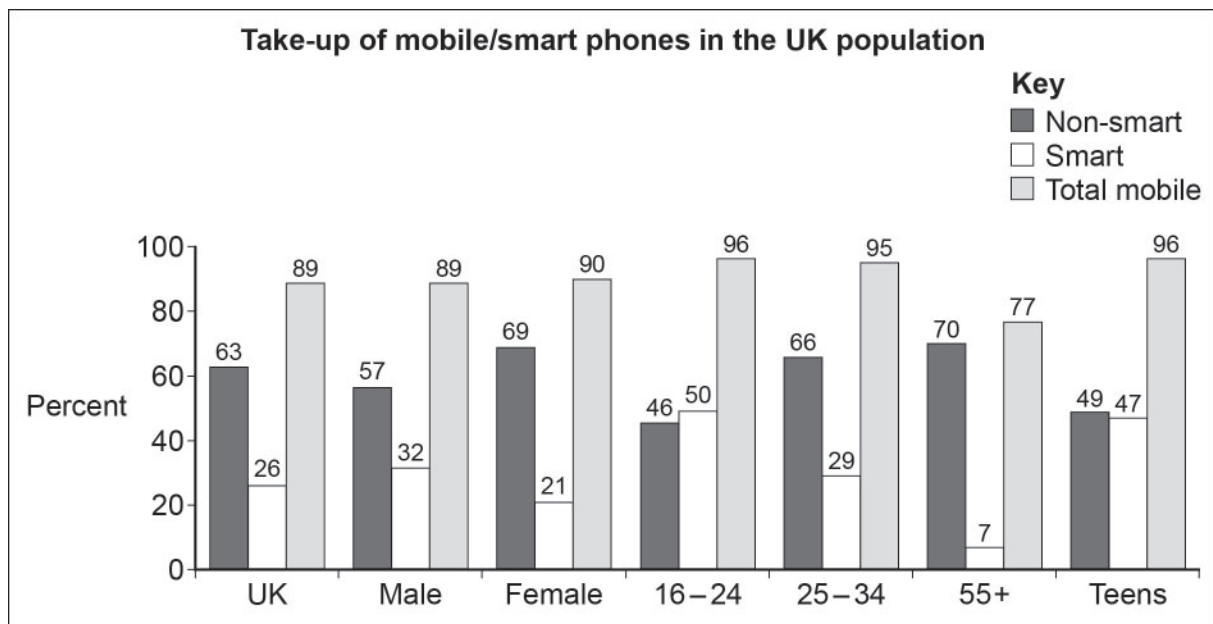

Source: Ofcom Omnibus Research, March 2011

A25 The sector with the biggest percentage of smartphone users is

- A females.
- B males.
- C teens.
- D 16-24 year olds.

A26 It is likely that more and more people will use smart phones to browse the internet and send and receive data. The problems this creates for the UK infrastructure include

- 1 larger capacity data cables will have to be installed across the UK.
- 2 the airwaves could become congested.
- 3 older telephone networks could overheat.
- 4 mobile phones will not be able to cope with the technological changes.

Answer

- A 1 and 2 only.
- B 3 and 4 only.
- C 1, 2 and 3 only.
- D all of the above.

Questions A27 and A28

A27 A ship sailed 30 miles south from its home port and then turned west for 40 miles.

Its final turn took it directly back home.

The total distance it travelled was

- A** 100 miles.
- B** 110 miles.
- C** 120 miles.
- D** 125 miles.

A28 Speed at sea is measured in knots (nautical miles per hour). A knot = 1.15 miles per hour.

The first two legs of the above journey were covered at an average speed of 23 knots.

How long did the first two legs of the journey take?

- A** 2 hours 38 minutes
- B** 3 hours
- C** 3 hours 48 minutes
- D** 4 hours

Turn over for the next question

Turn over ►

Questions A29 and A30

A29 The passage describes a dance move called a 'backfill'.

- 1 The dancer steps forward onto one foot raising the arms forward and overhead while lifting the other foot to the passé position.
- 2 Contracting the torso the dancer swings the arms backward while bending the supporting leg and reaching for the floor.
- 3 The dancer places the elevated foot at the back to provide a strong base support.
- 4 The dancer gradually lowers the body to the floor and uncurls to the supine position with arms extended behind.

The correct position of the dancer in step **4** of the choreographed move is

A



B



C



D



A30 The dancer below is performing a move called a 'grand jeté'.



Each of the following is involved in this move **except**

- A** extension.
- B** rotation.
- C** travelling.
- D** spring.

END OF SECTION A

Turn over for Section B

Turn over ▶

Section B

Stimulus Material

Study the following information and answer **all** the questions in Section B which are printed in the enclosed question paper/answer book.

Item A

Starbucks and Amazon characterise the death of the British high street



It's time for retailers large and small to do more to protect the high street as a community asset.

Starbucks and Amazon stand at opposite ends of the great high street debate – one a multinational chain, the other a cloud-based internet retailer – but together they are squeezing out the independent businesses local communities need.

The planners of the new type of high street situated within an out of town retail park, or even a single large scale supermarket, are now using

their financial muscle to drive out independent high street shops. Council business rents are rising beyond the reach of all but the most tenacious retailers. Meanwhile faceless online stores drive down prices, destroy the concept of service and turn shopping from a social activity into a mechanical transaction.

Big businesses need to recognise the negative impact they are having on communities and ask themselves if that is a sensible way to work. They need to take action themselves. We could ask government for action, but that is a long term strategy and without rapid change our high streets will be dead and buried.

Local consumers need to wake up to what they are losing when they are shopping online: product choice, quality service, local knowledge – and the ability to surprise a loved one with a gift at Christmas because it has a personal touch. In a rapidly homogenising world, shoppers should look to independents for a point of difference.

It must be made easier for independent retailers and consumers to meet. They should also look to use the tools of big business and the internet, to create ways to reach customers better and thus survive or even expand. High streets are great places, often full of character but their shops need to compete in a more positive way to exist in today's ever changing society. The website, MyHigh.St, helps that process, reminding smaller retailers that together they are strong.

Source: Text: adapted from an article by Tim Lewis © Guardian News and Media Ltd. 2012

Item B

UK total shop vacancies:	14.6 %
Number of empty shops:	40 000
Online sales:	10 % of retail sales
Predicted annual internet growth rate in 2013:	15 %
Predicted total retail sales growth in 2013:	1.5 %

Source: © Local Data Company 2013

Item C

‘The focus is too much on rescuing or recreating High Streets of old,’ says Bill Grimsey, former boss of Iceland stores. ‘It’s a waste of time. They can’t be saved. The reason town centres are dying is consumers don’t want them. We don’t shop like we used to. We have to stop harking back to the past and get on with the important task of working out what we need in the town centres of the future. While most people pay lip service to the notion of quaint town centres with a diverse range of independent shops, fewer and fewer people have supported them. They voted with their feet.’

If Grimsey’s views are accurate and consumers continue to change their habits towards using shopping malls and the internet, the number of shops that may become vacant over the next five years could well reach a third of all outlets.

Source: © Bill Grimsey, “Sold Out”: Filament Publishing 2012

END OF SECTION B

Turn over for Section C

Turn over ►

Section C

Answer **one** question, **either** Question 5 **or** Question 6.
Write your answers in the spaces provided on pages 8 to 19 of the other booklet.
There are a total of 30 marks for either question.

Either

- 5 Look at the items below and then answer the following questions.

Item D**Item E****Item F****Item G**

5 (a) Identify **four** illnesses against which vaccinations are regularly given to protect children. **[4 marks]**

5 (b) Explain **four** different ways technology may be used to treat a sick child whilst in hospital. **[8 marks]**

5 (c) Hospital treatments often use drugs that have been tested on animals.

The 'Statistics of Scientific Procedures on Living Animals 2012' show that 4.11 million procedures were started in the UK in 2012 – an increase of 8% from the year before.

Discuss the extent to which you agree with the continued expansion of drug testing on animals within the UK.

In your answer you may wish to consider animal rights, public reaction, alternative testing, other countries' views, as well as ideas of your own.

[18 marks]

Turn over for the next question

Turn over ►

or

6 Look at the items below and then answer the following questions.

Item H



Item I



Item J



Item K

India's mission to Mars

Mars orbiter mission 'Mangalyaan'

- ▶ India's first mission to the Red Planet
- ▶ 300-day cruise to Mars to explore the planet's surface features, mineralogy and atmosphere
- ▶ Cost: \$73 million (4.5 billion rupees)

Launch vehicle

New Delhi

Sriharikota Spaceport

Launched: November 5 2013

6 (a) Identify **four** charity organisations that seek to raise funds to help people in need. **[4 marks]**

6 (b) Explain **four** ways charities use celebrities to raise funds. **[8 marks]**

6 (c) Many tax campaigners were upset because the Chancellor promised to raise the overseas aid budget from £10.3 billion in 2014 to £11.1 billion in 2015.

Discuss the positive and negative aspects of the Government increasing levels of aid to overseas countries.

In your answer you may wish to consider: development, disasters, security and trade, as well as ideas of your own.

[18 marks]

END OF QUESTIONS

There are no questions printed on this page

Acknowledgement of copyright-holders and publishers

Permission to reproduce all copyright material has been applied for. In some cases efforts to contact copyright-holders have been unsuccessful and AQA will be happy to rectify any omissions of acknowledgements in future papers if notified.

Section A

- A5: Quote from "Never let me go" by Kazuo Ishiguro © Faber and Faber (2010)
 A6: "Black Holes and Baby Universes and Other Essays" by Stephen Hawking
 Published by Transworld
 Reprinted by permission of The Random House Group Ltd and Al Zuckerman.
 A7 & A8: Article text adapted from The Telegraph © Telegraph Media Group 2012
 Image: © John Robertson/Alamy 2014
 A9 & A10: © United Nations/Martine Perret
 A11 & A12: Image of the Carbon structure of Graphene © Thinkstock 2014
 A14: Tap Image © Thinkstock 2014
 A17: Image of William Byrd © The Life Collection/Getty Images
 A18: Image of fast-moving train © www.all-free-download.com
 A25: © Ofcom: The Communications Market Report 2011
 A29: Images © Franck Camhi/Alamy

Sections B & C:

- Item A: Text: © Guardian News & Media Ltd. 2012
 High Street Image: © Peter Titmuss/Alamy
 Item B: © Local Data Company 2013
 Item C: Extract from "Sold Out" by Bill Grimsey © Filament Publishing 2013
 Item D: Child getting measles vaccine © ChinaFotoPress/Getty Images
 Item E: Female patient MRI scan © MCT/Getty Images
 Item F: Baby in Intensive Care © Barcroft Media/Getty Images
 Item G: Mouse/Rat Experiment © Patrice Latron/Look at Sciences/Science Photo Library
 Item H: © WaterAid/Layton Thompson
 Item I: Children in Need backstage portrait © Dave J Hogan/Getty Images Entertainment
 Item J: © Claudia Dewald/Vetta/Getty
 Q4: Electrical Store Images: © Brooks Electrical 2014

Copyright © 2015 AQA and its licensors. All rights reserved.