

Candidate Name	Centre Number	Candidate Number

WELSH JOINT EDUCATION COMMITTEE
General Certificate of Secondary Education



CYD-BWYLLGOR ADDYSG CYMRU
Tystysgrif Gyffredinol Addysg Uwchradd

157/02

FRENCH

Listening and Responding

Foundation Tier

A.M. FRIDAY, 8 June 2007

(35 minutes approximately)

Examiner's Use Only

Total Marks	
------------------------	--

INSTRUCTIONS TO CANDIDATES

Write your name, centre number and candidate number in the spaces at the top of this page.

Answer **all** the questions. Where numbers are required, figures may be used.

You will hear a tape which contains a number of items in French and you will answer questions on each of these **in French** unless otherwise instructed.

Write your answers in the spaces provided in this question paper.

INFORMATION FOR CANDIDATES

Dictionaries are not allowed.

Before you hear the tape, you will be allowed **five minutes** to read the questions.

The tape will be played. After hearing the voices of the French speakers used on the tape, you will hear question 1 as it appears in your answer book. The French item will then follow. At the end of this there will be a pause and the item will then be repeated.

All the other questions will be heard in the same way.

There will be a pause of approximately 2 minutes at the end of the test before answer books are collected.

You may make notes or write your answers at any time.

The number of marks is given in brackets at the end of each question or part-question.

No certificate will be awarded to a candidate detected in any unfair practice during the examination.

1. Au snack

Il y a **deux** sections.

SECTION 1

Qu'est-ce que l'homme et la femme prennent?

Coche (✓) les bonnes cases.

	café	chocolat	sandwich	coca
L'homme				

[2]

	thé	eau	frites	chips
La femme				

[2]

SECTION 2

Qu'est-ce que l'homme et la femme prennent?

Coche (✓) les bonnes cases.

	limonade	coca	lait	gâteau
L'homme				

[2]

	eau	café	limonade	glace
La femme				

[2]

ROUGH NOTES

2. Delphine et Benoît parlent des vêtements. Coche (✓) les bonnes cases.

(a) Benoît aime:

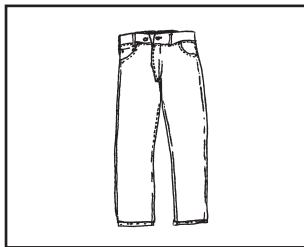

[2]

(b) Delphine aime:

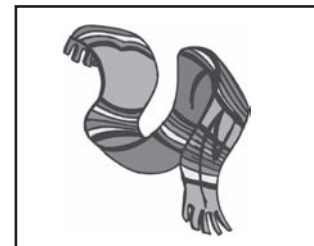
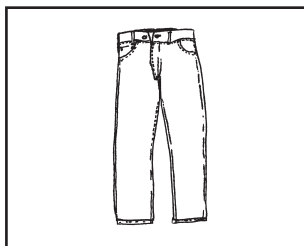

[2]

(c) Qui aime les chapeaux?

(i) Benoît

(ii) Delphine

(iii) Benoît et Delphine

[1]

ROUGH NOTES

3. Sophie cherche le musée. Elle demande des renseignements. Coche (✓) les bonnes cases.

(a) Sophie va au musée:







[1]

(b) Elle doit:

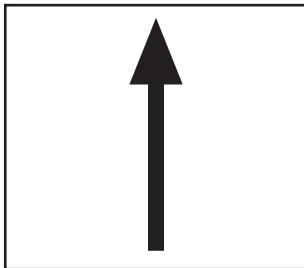

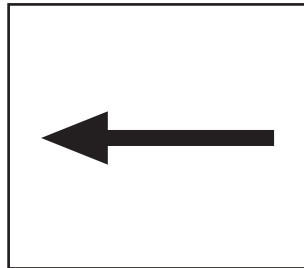

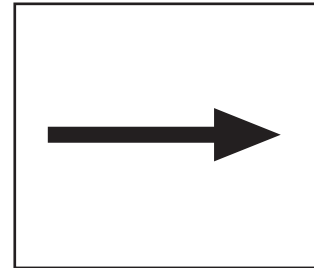

[1]

(c) Après le pont, elle doit:

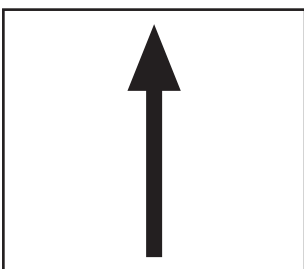

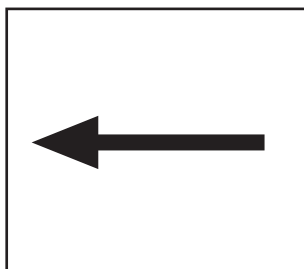

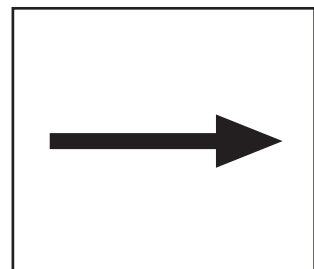

[1]

(d) Il faut combien de minutes:



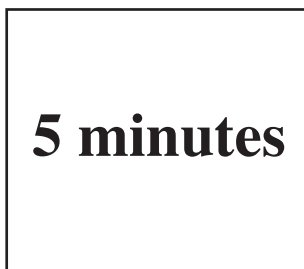



[1]

ROUGH NOTES

(e) Le musée est en face de:

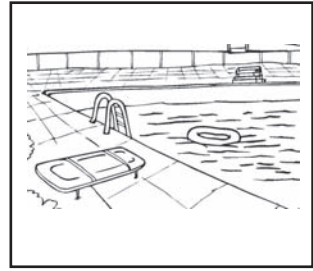
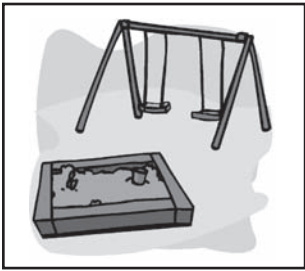

[1]

ROUGH NOTES

4. Que fait-il?

A quelle heure?

Coche (✓) les bonnes cases.

(a) Que fait-il:



[1]

A quelle heure:



[1]

(b) Que fait-il:

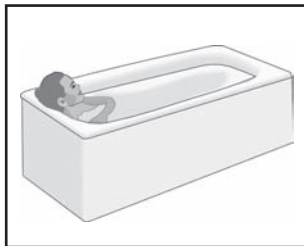

[1]

A quelle heure:

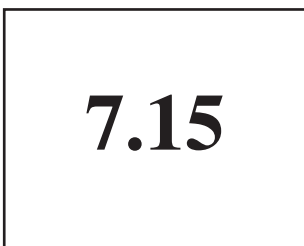

[1]

ROUGH NOTES

(c) Que fait-il:



[1]

A quelle heure:



[1]

ROUGH NOTES

5. Julie, la correspondante française de Siân, arrive chez elle.

Coche (✓) les bonnes cases.

SECTION 1

(a) La chambre de Julie est en face de:







[1]

(b) Dans sa chambre, il y a:







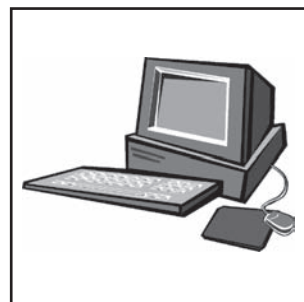



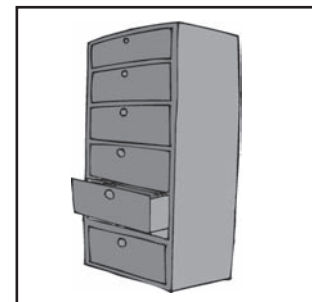

[3]

ROUGH NOTES

SECTION 2

(c) Julie aime beaucoup les films:

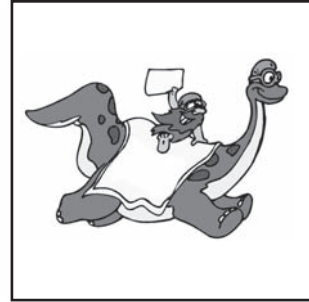

[2]

ROUGH NOTES

6. Le train arrivera à quel quai et à quelle heure? Coche (✓) les bonnes cases.

(a)

Platform 1	<input type="checkbox"/>	Platform 2	<input type="checkbox"/>	Platform 3	<input type="checkbox"/>	[1]
-----------------------	--------------------------	-----------------------	--------------------------	-----------------------	--------------------------	-----

19.20	<input type="checkbox"/>	19.30	<input type="checkbox"/>	19.40	<input type="checkbox"/>	[1]
--------------	--------------------------	--------------	--------------------------	--------------	--------------------------	-----

(b)

Platform 13	<input type="checkbox"/>	Platform 12	<input type="checkbox"/>	Platform 11	<input type="checkbox"/>	[1]
------------------------	--------------------------	------------------------	--------------------------	------------------------	--------------------------	-----

10.40	<input type="checkbox"/>	14.10	<input type="checkbox"/>	14.40	<input type="checkbox"/>	[1]
--------------	--------------------------	--------------	--------------------------	--------------	--------------------------	-----

ROUGH NOTES

7. English Question

Karine is talking about her family.

Answer the questions **in English**.

There are **two** sections.

SECTION 1

- (a) How old is her little brother? [1]
- (b) Why does she get annoyed with him? [1]
- (c) Who is Boris? [1]

SECTION 2

- (d) In what **two** ways do her parents allow her freedom? [2]
-
- (e) What does she plan to do next year? [1]

ROUGH NOTES