

Candidate Name	Centre Number	Candidate Number
		0



General Certificate of Secondary Education

294/02

**ELECTRONICS
MODULE TEST E2
HIGHER TIER**

P.M. FRIDAY, 11 January 2008
(45 minutes)

For Examiner's use only

Total Mark	
-----------------------	--

ADDITIONAL MATERIALS

In addition to this examination paper you may need a calculator.

INSTRUCTIONS TO CANDIDATES

Write your name, centre number and candidate number in the spaces at the top of this page.

Answer **all** the questions in the spaces provided in this booklet.

INFORMATION FOR CANDIDATES

The number of marks is given in brackets at the end of each question or part-question.

No certificate will be awarded to a candidate detected in any unfair practice during the examination.

BLANK PAGE

2. (a) Here is the signal produced by an **astable** circuit.

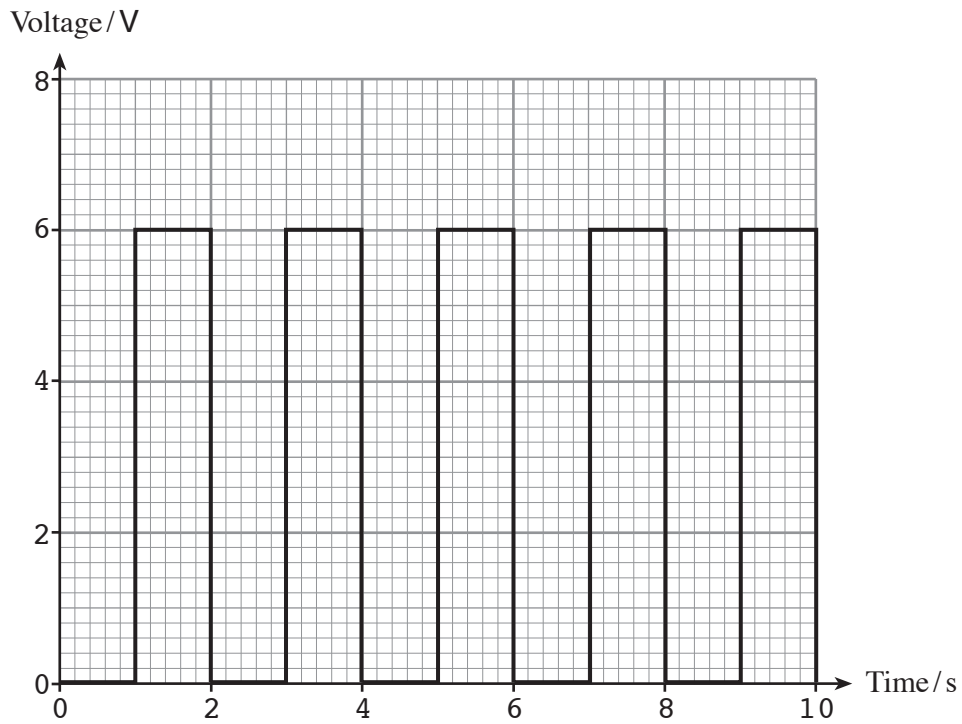

- (i) What is the amplitude of the signal? [1]
- (ii) What is the period of the signal? [1]
- (iii) Calculate the frequency of the signal. [1]

.....

.....

(b) The circuit diagram shows a **monostable** circuit using a 555 timer.

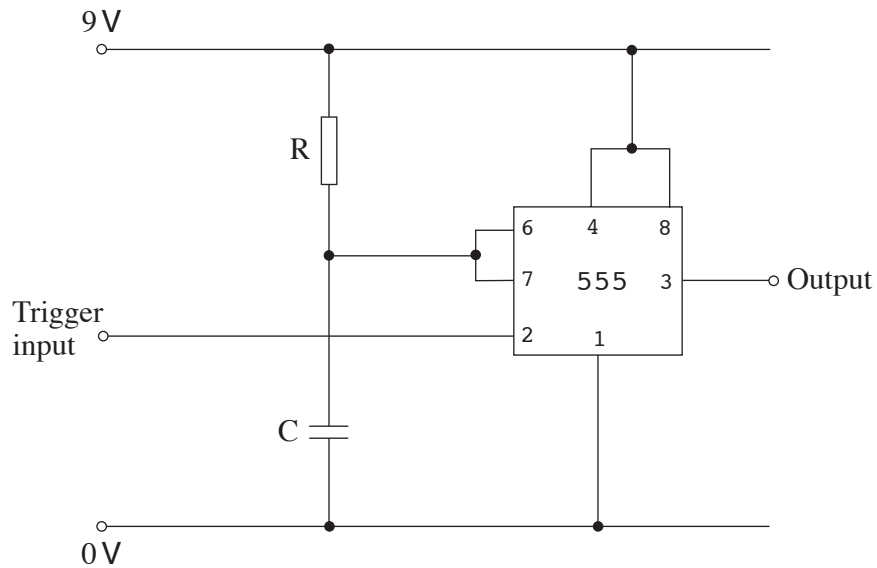

- (i) Using the axes provided to sketch the output signal produced by a 10 second monostable circuit, which is triggered at the time shown. [2]

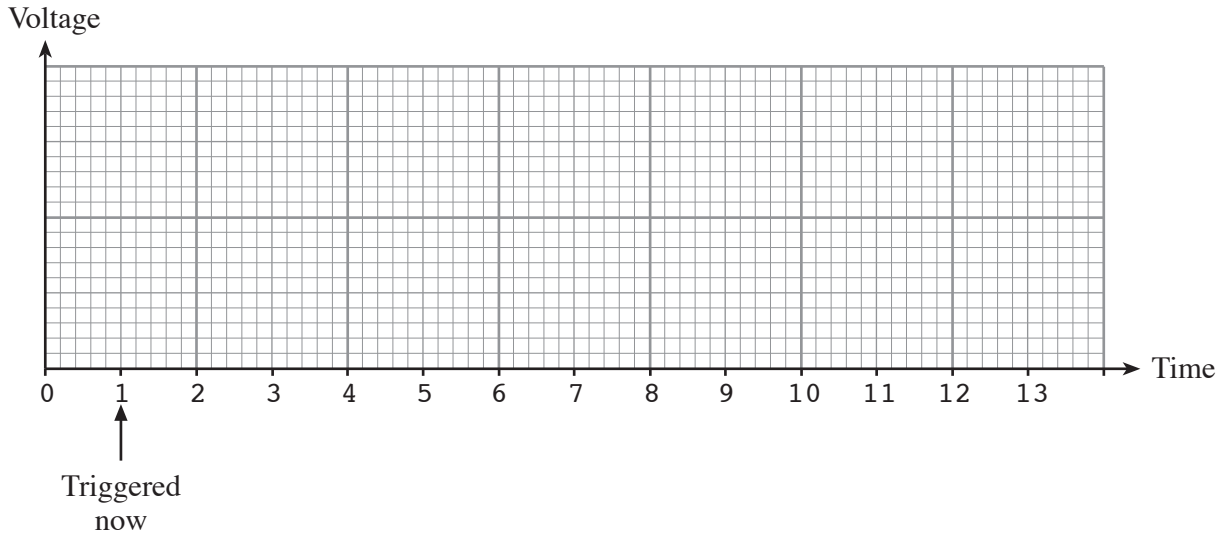

- (ii) The monostable *time delay* can be found from the formula:

$$T = 1.1 \times RC \text{ (where } T \text{ is in seconds, } R \text{ is in } M\Omega \text{ and } C \text{ is in } \mu F.)$$

Here are four resistor/capacitor sets.

Set	Resistor	Capacitor
A	47 kΩ	100 μF
B	82 kΩ	100 μF
C	47 kΩ	220 μF
D	82 kΩ	220 μF

Which one will produce a time delay nearest to 10 seconds?

Show how you obtained your answer.

[2]

.....

.....

.....

.....

The answer is set

3. (a) Complete the truth table for the following logic system:

[3]

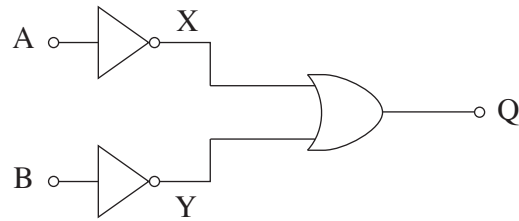

A	B	X	Y	Q
0	0			
0	1			
1	0			
1	1			

- (b) Redraw the system replacing **each** of the three gates with its equivalent NAND gate arrangement. [3]

- (c) Draw a line through **each** redundant gate. [1]

4. A freezer has an electronic system to warn the user if the temperature inside rises above freezing point.

The system uses a temperature sensor, a latch and a buzzer.

- A D-type flip-flop is set up as a latch and outputs a logic 1 to make the buzzer sound.
- A switch connected to the latch is used to reset it.

Here is part of the circuit diagram for the latch.

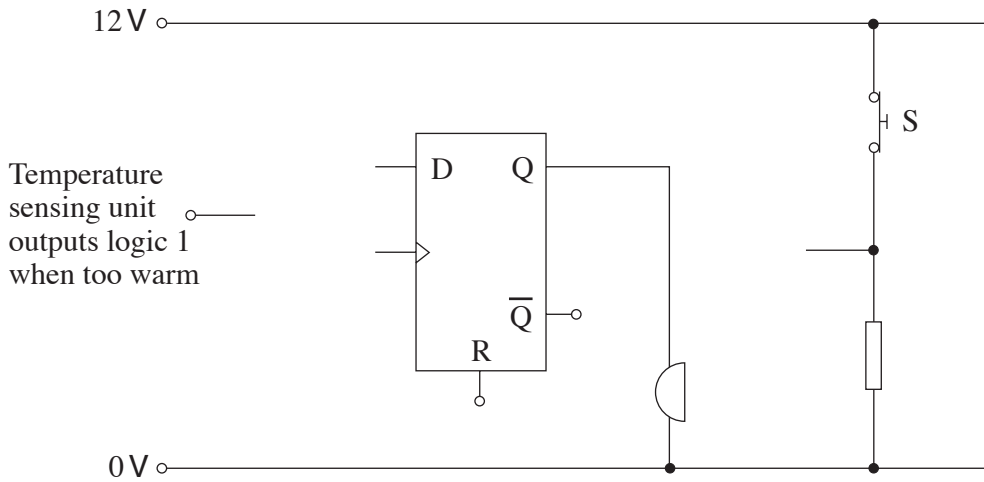

(a) Complete the circuit diagram.

[3]

(b) The signal from the temperature-sensing unit is shown in the following graph. Use the axes provided to draw the signals produced by the Q and \bar{Q} outputs of the latch. The Q output is at logic 0 initially.

[3]

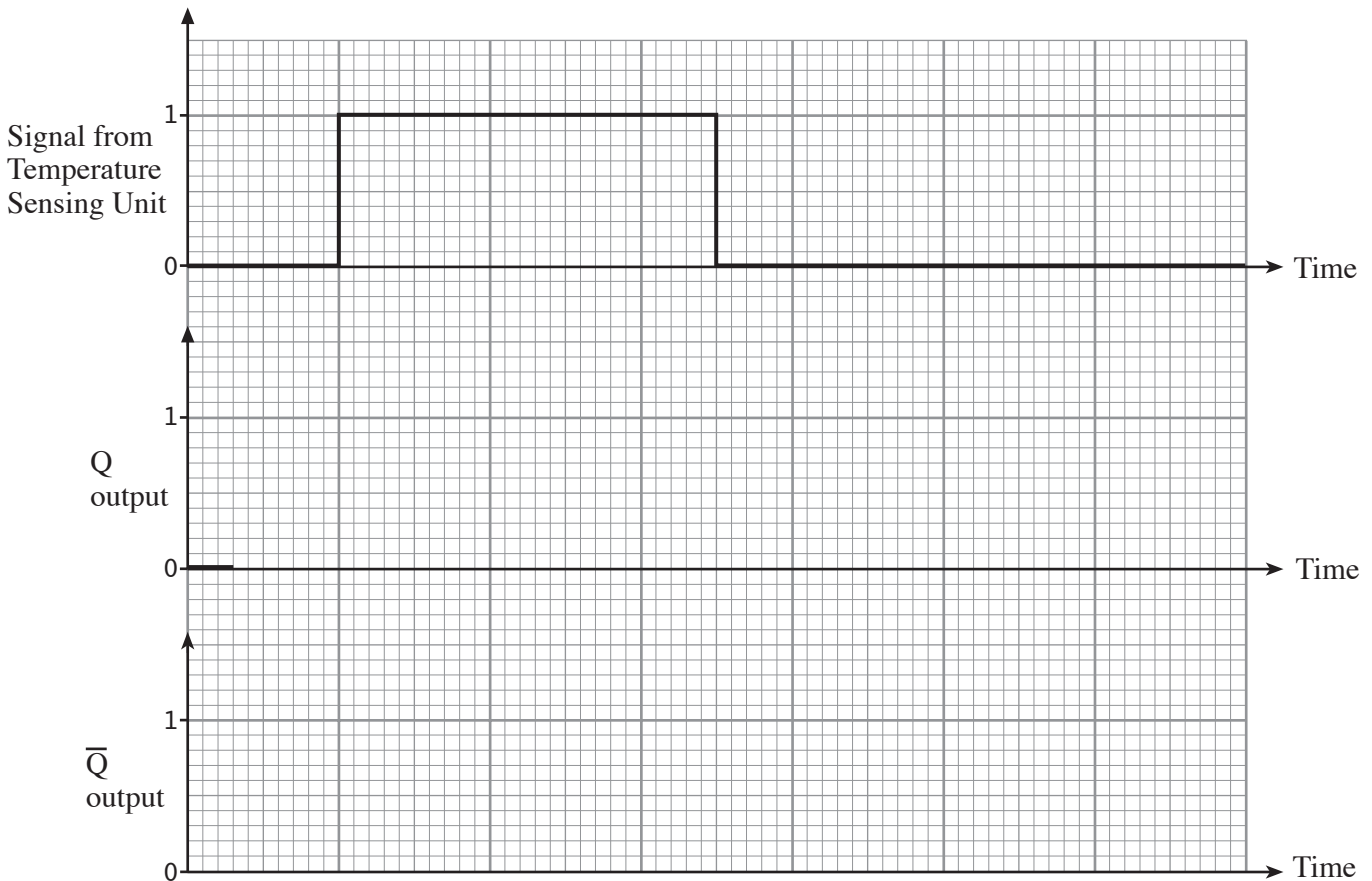

5. Two D-type flip-flops can be used to make a 2-bit binary up-counter.

(a) Complete the circuit diagram for this counter by adding the four connections needed. [3]

(b) Label the outputs A and B, where B is the most significant bit (msb). [1]

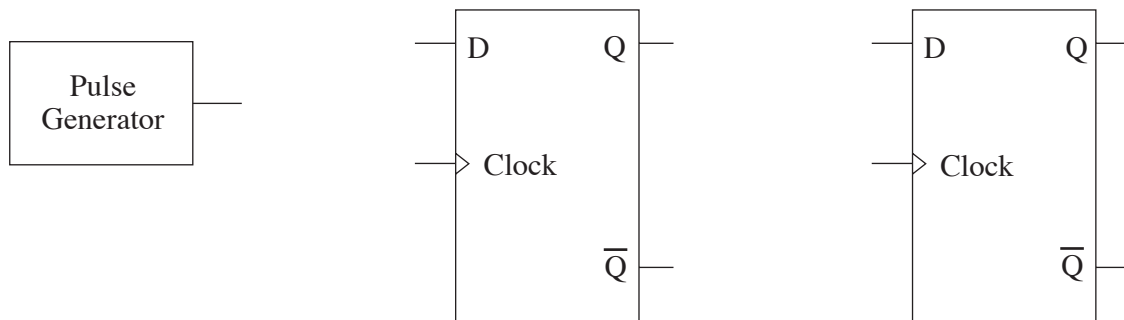

BLANK PAGE

6. (a) This is the block diagram for a set of traffic lights for a model village.

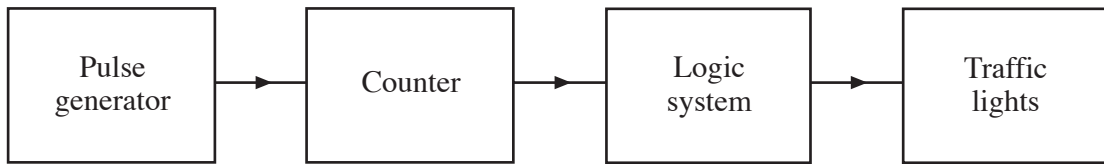

The circuit diagram for the counter and logic system is shown below.

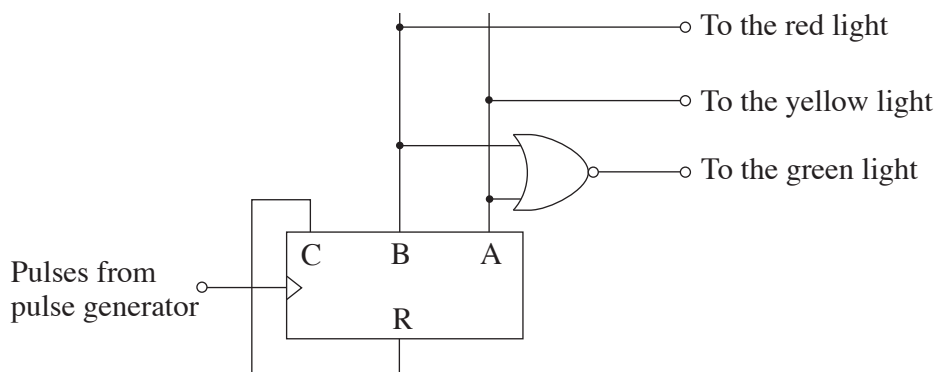

The table shows the possible output states for the counter.

Pulse number	Counter outputs			Traffic lights		
	C	B	A	Red light	Yellow light	Green light
0	0	0	0			
1	0	0	1			
2	0	1	0			
3	0	1	1			
4	1	0	0	Reset		

Use the counter outputs to decide what signals are sent to the traffic lights.

Complete the table to show whether logic 0 or logic 1 signals are sent to the red, yellow and green lights. [4]

(b) The pulse generator circuit is shown below.

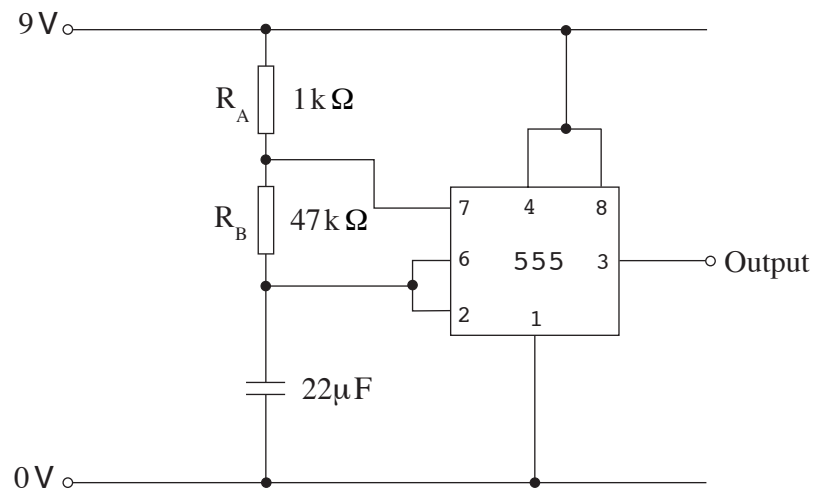

The approximate value of the frequency f , in Hz, of the pulse generator is given by the formula:

$$f = \frac{0.7}{R_B C}$$

where R_B is in Ω (ohms) and C is in F (farads).

Use this formula to calculate the frequency of the pulse generator.

[3]

.....

.....

.....

7. Here is the block diagram for a burglar alarm.

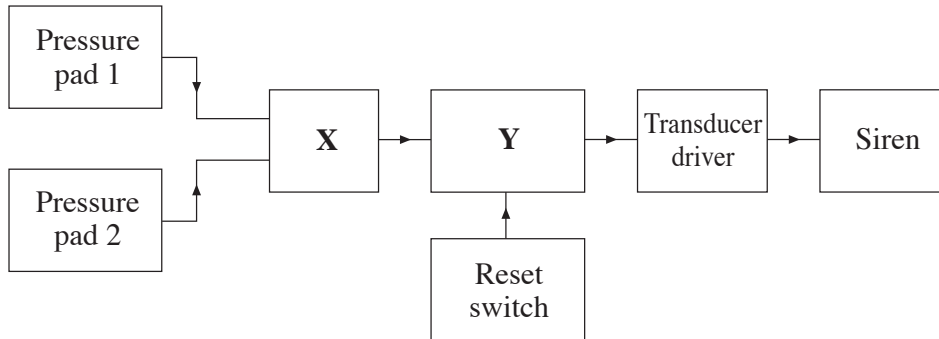

The siren sounds if someone stands on either pressure pad. It then stays on until the reset switch is pressed.

(a) What type of logic gate is required in block X? [1]

Answer

(b) Which one of the following subsystems is used for block Y? [1]

latch monostable counter AND gate

Answer

(c) A simple version of this system uses a thyristor. Complete the circuit diagram by adding a thyristor, reset switch and necessary connections. [4]

