

Centre Number						Candidate Number				
Surname										
Other Names										
Candidate Signature										



General Certificate of Secondary Education
Specimen Paper

Electronics

Unit 1: Written Paper

Date: Time

<p>For this paper you must have:</p> <ul style="list-style-type: none"> • a pencil and a ruler • a calculator.

Time allowed: 2 hours

Instructions

- Use black ink or black ball-point pen.
- Fill in the boxes at the top of this page.
- Answer **all** questions.
- Answer the questions in the space provided. Answers written on blank pages or in margins will not be marked.
- Show the working of your calculations.

Information

- The maximum mark for this paper is 150.
- The marks for the questions are shown in brackets.
- A list of formulae and other information, which you may wish to use in your answers, is provided on page 2.
- You are expected to use a calculator where appropriate.
- Any correct electronics solution will gain credit.
- You are reminded of the need for good English and clear presentation in your answers.

For Examiner's Use	
Examiner's Initials	
Question	Mark
1	
2	
3	
4	
5	
6	
7	
8	
TOTAL	

Information Sheet

The following information may be useful when answering some questions in this examination.

Power

Power = Voltage \times Current; $P = VI$

Amplifiers

Voltage gain $G_V = \frac{V_{out}}{V_{in}}$

Resistor colour code

The colours in the resistor colour code correspond to the following values.

BLACK	0	YELLOW	4	GREY	8
BROWN	1	GREEN	5	WHITE	9
RED	2	BLUE	6		
ORANGE	3	VIOLET	7		

The fourth band colour gives the tolerance

GOLD $\pm 5\%$ SILVER $\pm 10\%$ No fourth band $\pm 20\%$

Resistor printed code (BS 1852)

R means $\times 1$ K means $\times 1000$ M means $\times 1\,000\,000$

Position of the letter gives the decimal point.

Tolerances are indicated by adding a letter at the end.

J $\pm 5\%$ K $\pm 10\%$ M $\pm 20\%$

e.g. 5K6J = $5.6\text{ k}\Omega \pm 5\%$

Preferred values for resistors (E24 SERIES)

1.0, 1.1, 1.2, 1.3, 1.5, 1.6, 1.8, 2.0, 2.2, 2.4, 2.7, 3.0, 3.3, 3.6, 3.9, 4.3, 4.7, 5.1, 5.6, 6.2, 6.8, 7.5, 8.2, 9.1 and multiples of ten.

Resistance

Resistance = $\frac{\text{Voltage}}{\text{Current}}$ $R = \frac{V}{I}$

Effective resistance, R, of up to four resistors in series is given by $R = R_1 + R_2 + R_3 + R_4$

Effective resistance, R, of two resistors in parallel is given by $\frac{1}{R} = \frac{1}{R_1} + \frac{1}{R_2}$

A.C. waveforms

(a) Frequency of waveform = $\frac{1}{\text{Time period}}$; $f = \frac{1}{T}$

(b) peak value = $1.4 \times$ rms value

Astable and monostable generators using 555 timers

(a) Monostable mode, time period $T = 1.1 R_1 \times C_1$

(b) Astable mode, time period $T = \frac{(R_1 + 2R_2)C_1}{1.44}$

Turn over for the first question

Turn over ►

Answer **all** questions in the spaces provided.

- 1 A technician, working alone in an electronics workshop, is repairing an electronic circuit. The workbench and the circuit are shown below.

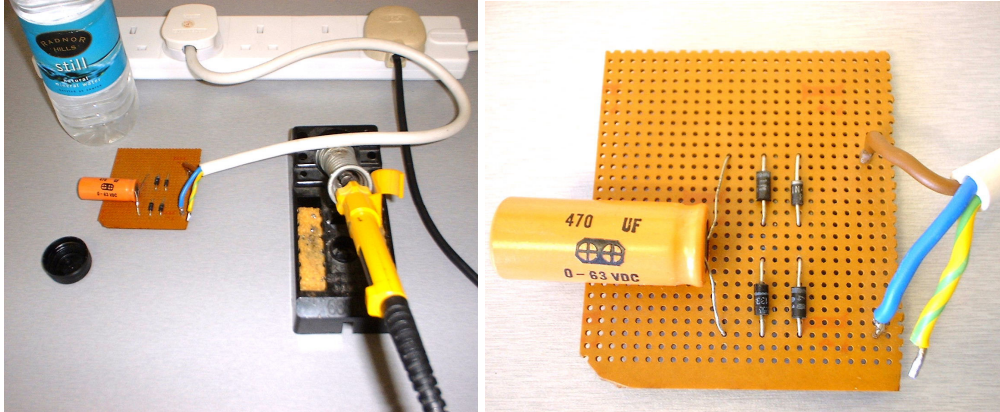

- 1 (a) State **five** hazards that could occur in this situation.

- 1
- 2
- 3
- 4
- 5

(5 marks)

- 1 (b) The technician touches the mains supply.
State **two** different effects this will have on him.

- 1
- 2

(2 marks)

- 1** (c) You discover the technician after he has touched the mains supply.
Give **three** actions you would take to help him.

1

2

3

(3 marks)

10

Turn over for the next question

Turn over ►

- 2 An electronics engineer working for a heating company is designing an electronic temperature control system for a new central heating boiler. The first stage of the design will be for the electronics engineer to produce a system diagram. This is shown below.

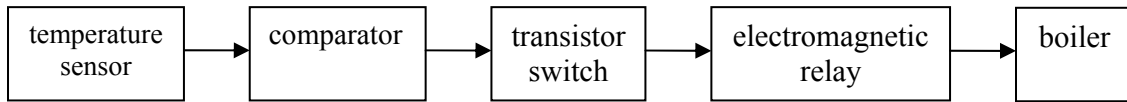

In her system diagram, which block represents

- 2 (a) (i) an input (1 mark)
- 2 (a) (ii) an output (1 mark)
- 2 (a) (iii) an analogue to digital converter? (1 mark)

In her final design the engineer will use a variety of components. In which block could she use

- 2 (b) (i) an op-amp (1 mark)
- 2 (b) (ii) a thermistor? (1 mark)
- 2 (c) Which **two** blocks use a small current to control a larger current?
- 1 (2 marks)
- 2

- 2 (d) In testing the final system, the engineer sets the temperature sensor to 22°C. Describe **three** actions of the system when the temperature drops below the set level.
- 1
- 2
- 3 (3 marks)

- 3 A safety system for a lorry park is designed using light beam sensors and logic gates.
- 3 (a) Label the **three** different types of logic gate in the diagram of the alarm processor below.

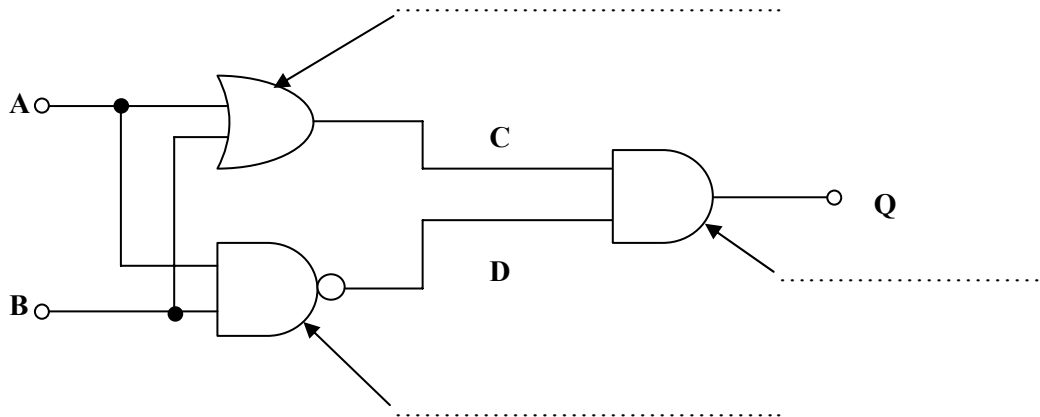

(3 marks)

- 3 (b) Complete the truth table below to describe the operation of the logic circuit in part (a).

A	B	C	D	Q
0	0			
0	1			
1	0			
1	1			

(6 marks)

- 3 (c) The inputs **A** and **B** are connected to two beam sensors across the access road to the lorry park as shown below.
The sensors give a logic 1 when the beam is broken.
A lorry is shown travelling towards the sensors.

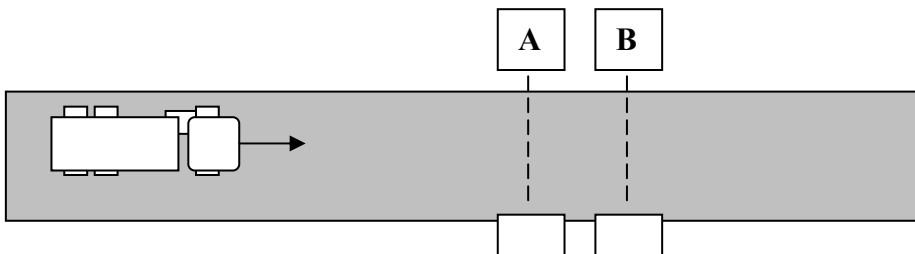

On the diagram above draw the position of the lorry when the output of the system, **Q**, first gives a logic 1.

(1 mark)

4 A technician is asked to sort and identify some electronic components as shown below. State the name and the parameters for each of the components.

4 (a)

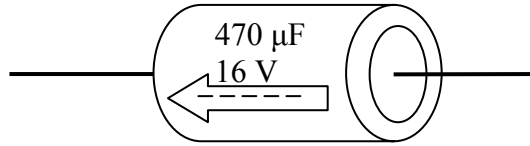

Component name

Value

Maximum working voltage

What else is indicated on the component casing?

.....

(4 marks)

4 (b)

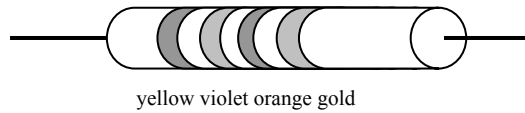

Component name

Value

What is a function of this component in a circuit?

.....

(6 marks)

- 5 A garden centre occasionally uses a pump to circulate the water in a fish pond. When the pump is under water it is difficult to know if it is working or not. You want to design a circuit in which an LED will come on to indicate when the pump is working. You decide to use the circuit shown below.

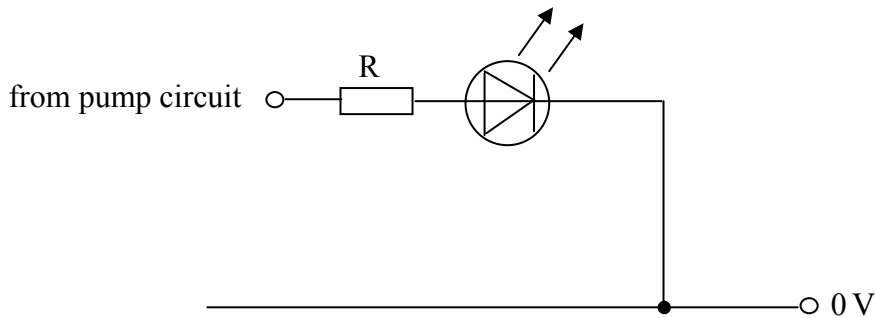

- 5 (a) The LED has a resistor, R, in series with it. The LED has 2 V across it when it is conducting. Calculate the voltage across the resistor if the pump circuit output is 9 V.

.....
(1 mark)

- 5 (b) The LED must **not** carry more than 20 mA of current. What is the value of the series resistor required?

.....
.....
(2 marks)

- 5 (c) (i) What preferred value of resistor should be used?

.....
(1 mark)

- 5 (c) (ii) Label the coloured bands on this resistor assuming it has a tolerance of 5%.

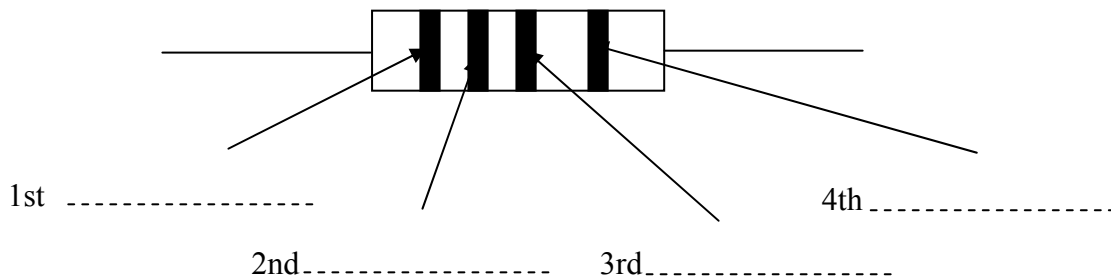

(4 marks)

8

Turn over ►

- 6 (a) The block diagram shows the subsystems of an audio entertainment system. The subsystems are a tuner, an amplifier, loudspeakers and a CD player. On the dotted lines label the names of the subsystems.

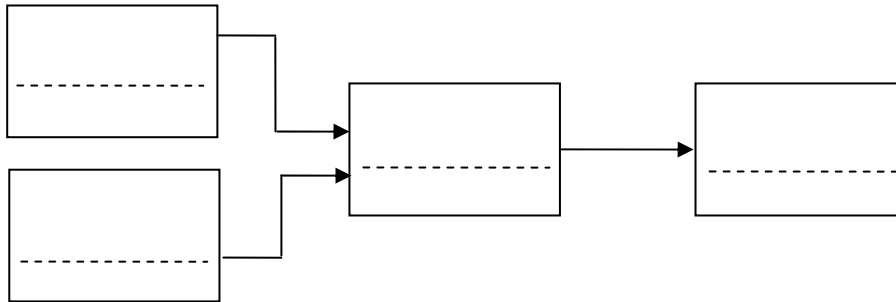

(4 marks)

- 6 (b) A simple radio receiver is made by connecting together the subsystems shown below.

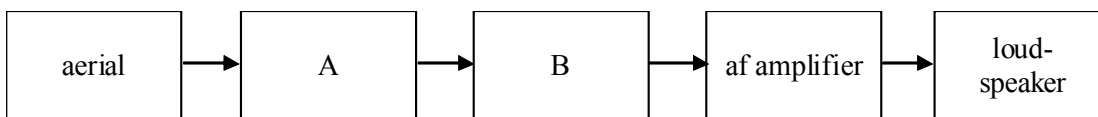

- 6 (b) (i) State the name and function of A.

Name.....

Function.....

.....

(3 marks)

- 6 (b) (ii) State the name and function of subsystem B.

Name.....

Function.....

.....

(3 marks)

- 6 (c) Explain what is meant by selectivity in a radio system.

.....

.....

(2 marks)

- 6 (d) Radio signals can be FM or AM.

- 6 (d) (i) What do the letters FM stand for?

.....

(1 mark)

6 (d) (ii) What do the letters AM stand for?

.....
 (1 mark)

6 (e) On the axes below draw diagrams to show how the unmodulated radio frequency carrier wave and the audio frequency wave are combined to produce an AM and an FM modulated radio wave.

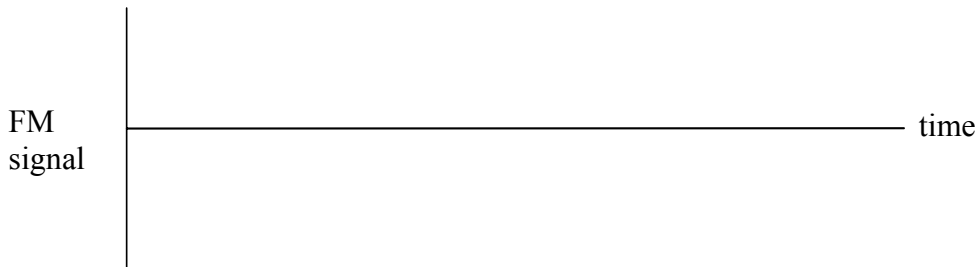
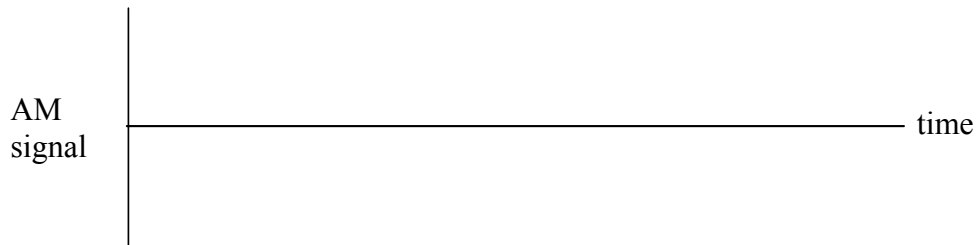
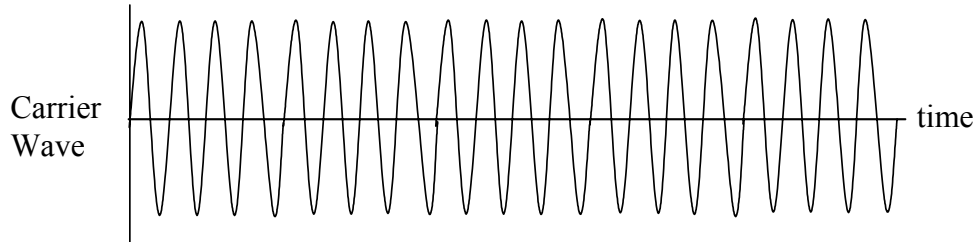
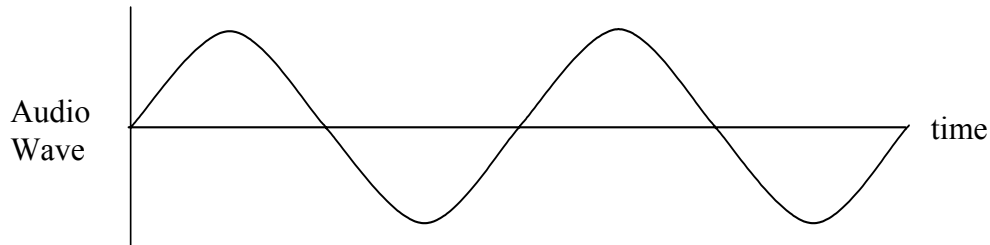

(4 marks)

Turn over ►

- 7 A traffic engineer designs a flowchart that describes the action of a traffic light system that is capable of reacting to the length of the queue of traffic waiting at a red light.

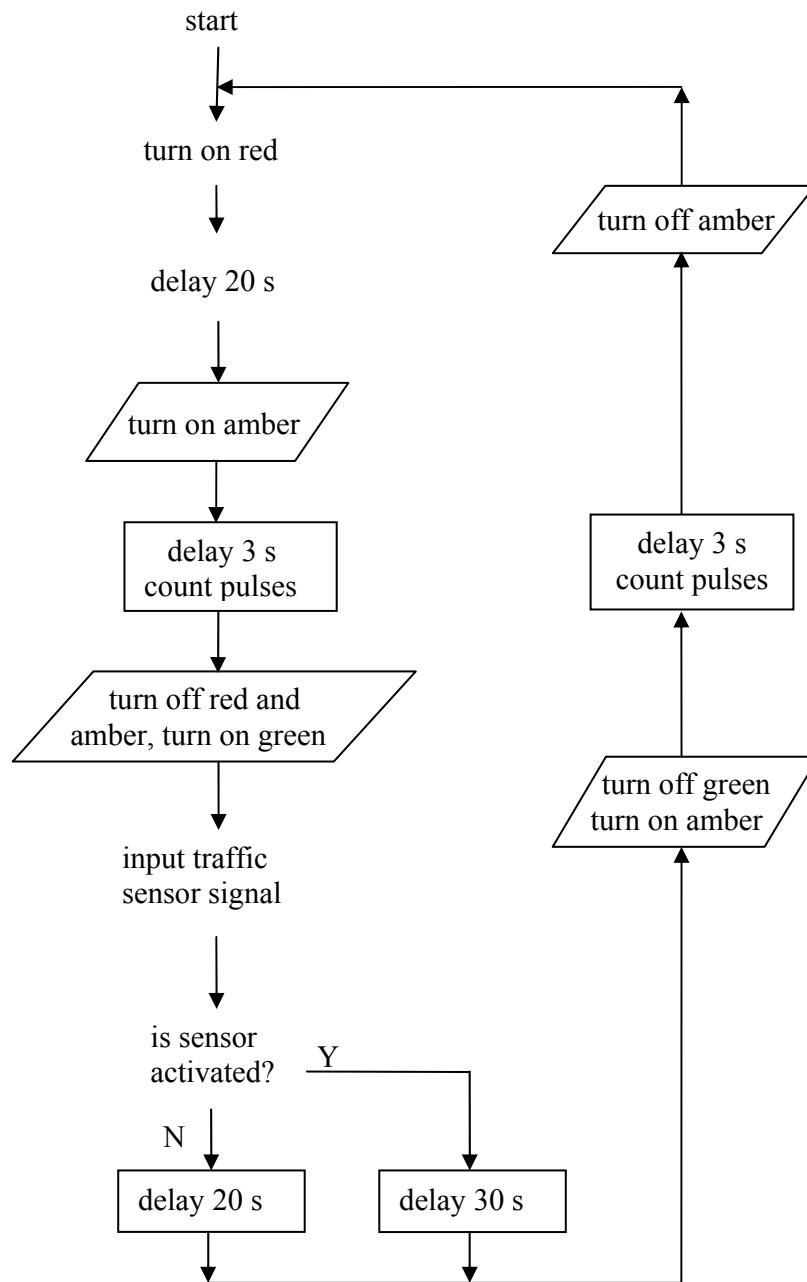

- 7 (a) On the flowchart draw the correct flowchart symbols at **five** places where they are missing. (5 marks)
- 7 (b) Label on the flowchart:
a decision box, an input box, a loop, an output box and a process box. (5 marks)

- 7 (c) (i) What length of time elapses from start before the green light turns on?
.....
(1 mark)
- 7 (c) (ii) The traffic sensor indicates a long queue of traffic. How does this alter the behaviour of the traffic light system compared to a short queue of traffic?
.....
(1 mark)
- 7 (c) (iii) How many times in one cycle of events is the amber light switched on?
.....
(1 mark)
- 7 (c) (iv) For how long is the amber light switched on in one cycle of events?
.....
(1 mark)
- 7 (c) (v) What length of time elapses from when the red light switches on, to the next time it switches on if there is a long queue?
.....
(1 mark)

Question 7 continues on the next page

Turn over ►

- 7 (d) Describe in your own words the operation of this traffic light system commencing from the switching on of the green light and there is only a short queue of traffic.

Answer this question in continuous prose, the quality of written communication will be assessed in your answer.

.....

.....

.....

.....

.....

.....

.....

.....

.....

.....

.....

.....

.....

.....

.....

.....

(5 marks)

<hr/> 20

- 8 An engineer working for a food canning company has designed a new packaging unit for different sized cans of food.

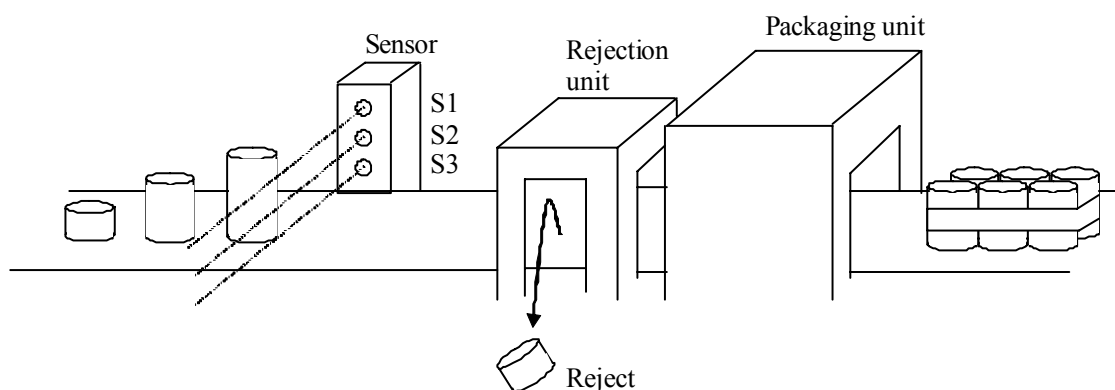

Three light beams and sensors S1, S2 and S3 are arranged as shown. The sensors are used to detect the size of the cans (small, medium or large) on the conveyor belt. Signals from the sensors are used to operate the rejection unit which will only allow the correct size of can to pass through to the packaging unit. Each sensor gives a high output when light is shining on it and a low output when a can passes.

- 8 (a) When a medium sized can passes the sensors, it breaks the beams to S2 and S3 and the outputs from the sensors are shown below

S1	S2	S3
1	0	0

- 8 (a) (i) Explain why the sensor outputs shown in the table below can never occur.

S1	S2	S3
0	1	1

.....

(1 mark)

- 8 (a) (ii) The sensors provide an input to a system of logic gates, which provide a high signal to the rejection unit when a large or small can is detected. Complete the truth table below for the system of gates which does this.

	S1	S2	S3	Output to rejection unit
No can	1	1	1	0
Small can				1
Medium can				
Large can				1

(4 marks)

Question 8 continues on the next page

Turn over ►

- 8 (a) (iii) The engineer wants to use a system which provides the high signal to the rejection unit when a small can is detected. In preparing a test for his final design he decides to use only AND and NOT gates. Draw a subsystem of gates which could be used.



(4 marks)

- 8 (b) (i) Complete the truth table for this system of gates.

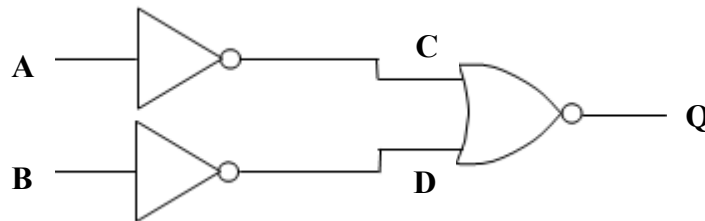

A	B	C	D	Q
0	0			
0	1			
1	0			
1	1			

(3 marks)

- 8 (b) (ii) The canning company needs to be able to accurately record the number of cans packed. The engineer produces another system for setting and counting cans. This subsystem is to be made only from NOR gates. The subsystem is shown below.

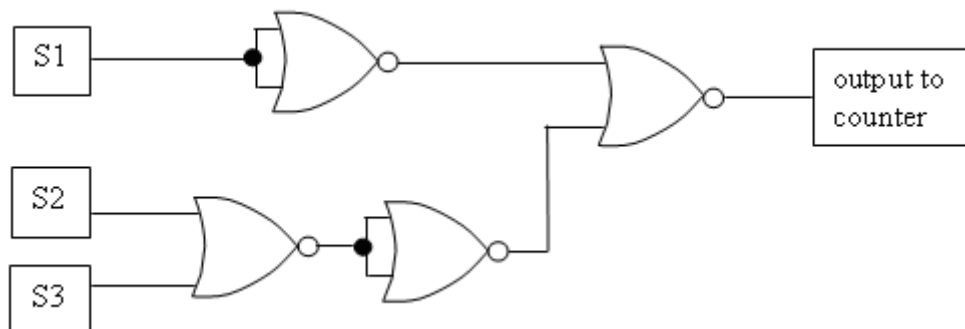

On the diagram above mark with an X, a gate which is being used as a NOT gate and draw a ring around three gates which are connected in a way that makes them equivalent to an AND gate.

(2 marks)

- 8 (b) (iii) The engineer now builds the circuit on a breadboard as shown below. Complete the connections on the circuit board below by adding **four** wires and labelling the output.

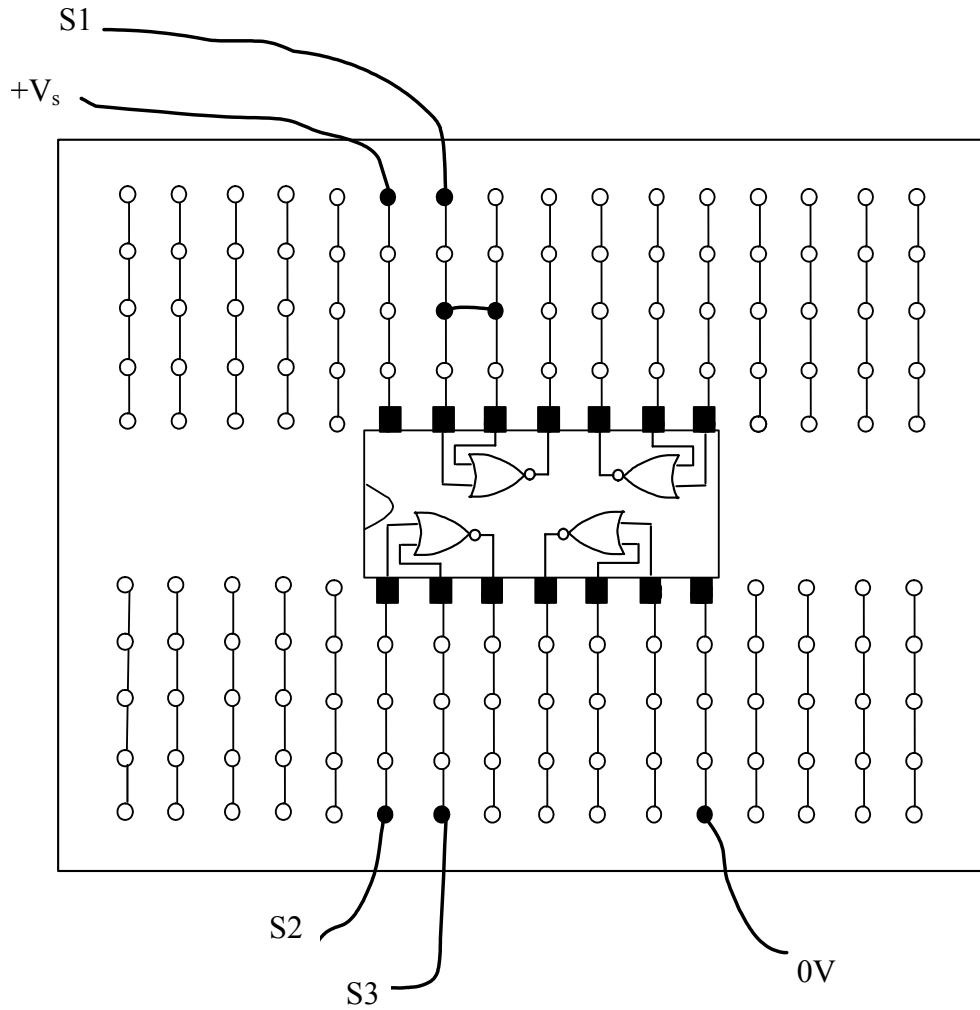

(5 marks)

19

Turn over ►

- 9 In a factory producing chocolate bars, the equipment used to melt, stir and pump chocolate into moulds is shown below.

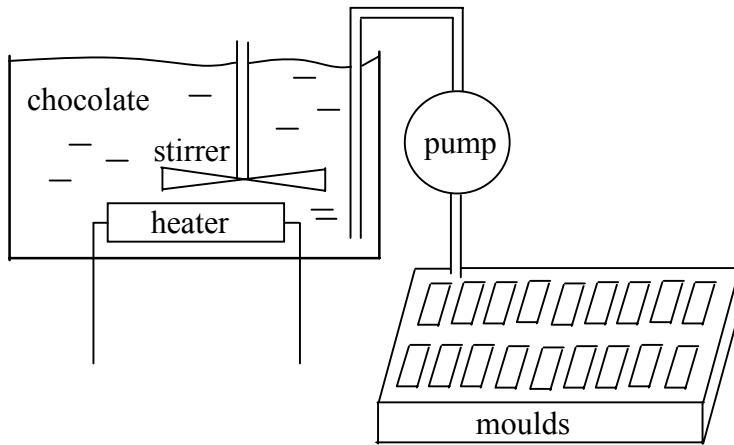

The heater, stirrer and pump are controlled electronically by the system shown below.

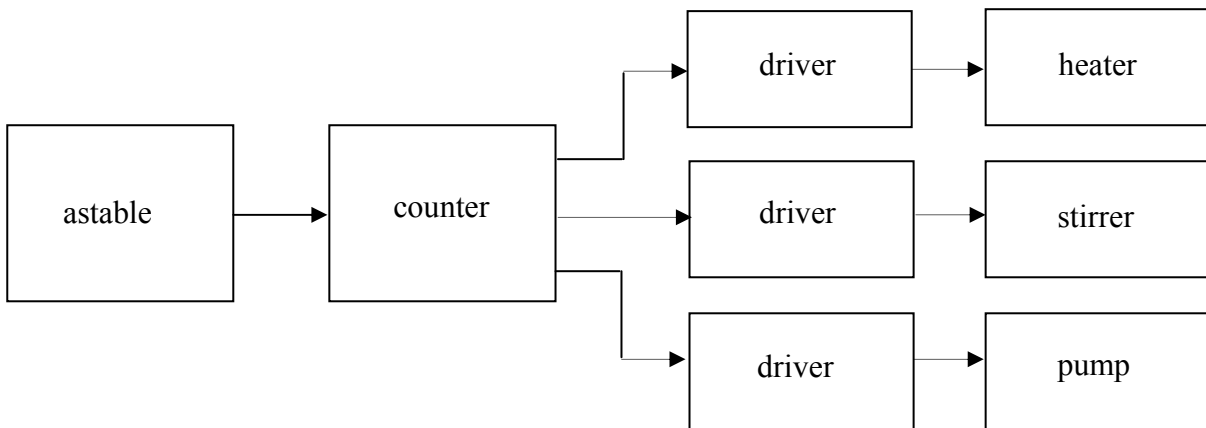

- 9 (a) The astable uses a 555 timer IC to produce pulses. Complete the circuit diagram below to show how the 555 timer should be connected. Add a resistor (R_2), a capacitor and the wire links needed.

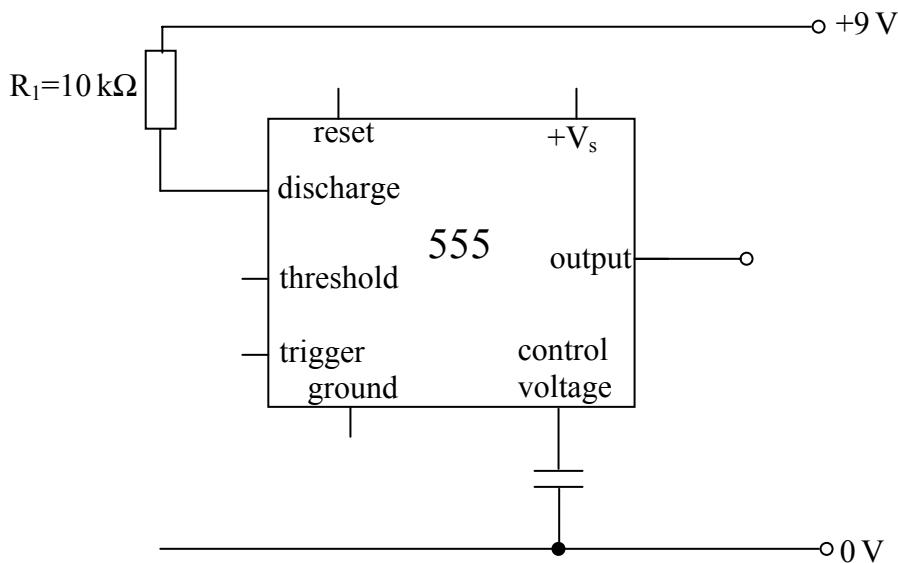

(6 marks)

- 9 (b) Show that the period of the pulses produced by the astable will be approximately 30 s if the value of the timing capacitor is $47\mu\text{F}$ and the value of R_2 is $470\text{ k}\Omega$.

.....

.....

.....

(3 marks)

- 9 (c) A 4017 IC below is used as the counter.

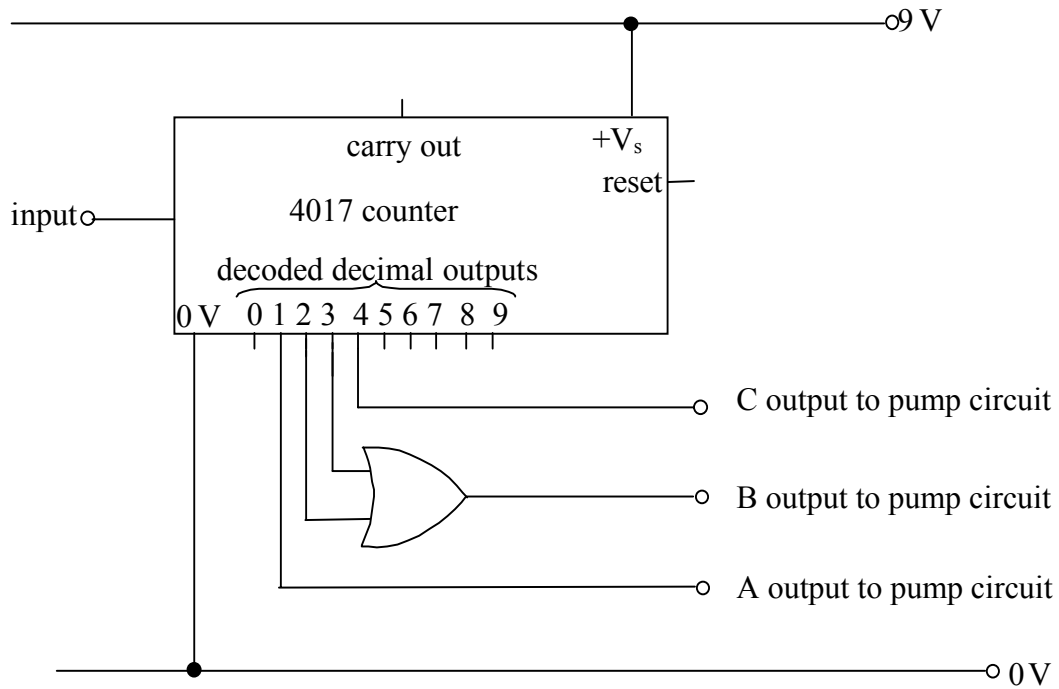

- 9 (c) (i) Add a resistor and push switch which could be used to provide a high voltage to reset the 4017 type counter when the switch is pressed.

(2 marks)

- 9 (c) (ii) Explain why the resistor is needed as well as the switch.

.....

.....

(2 marks)

Question 9 continues on the next page

Turn over ►

- 9 (d) (i) The 4017 type counter is reset and the 555 timer is switched on and produces the pulses below.
Complete the timing diagrams for the points A, B and C.

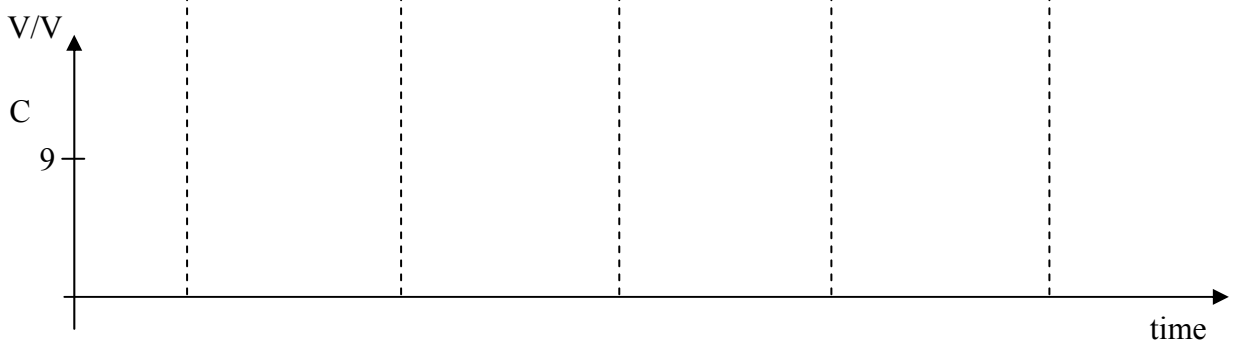
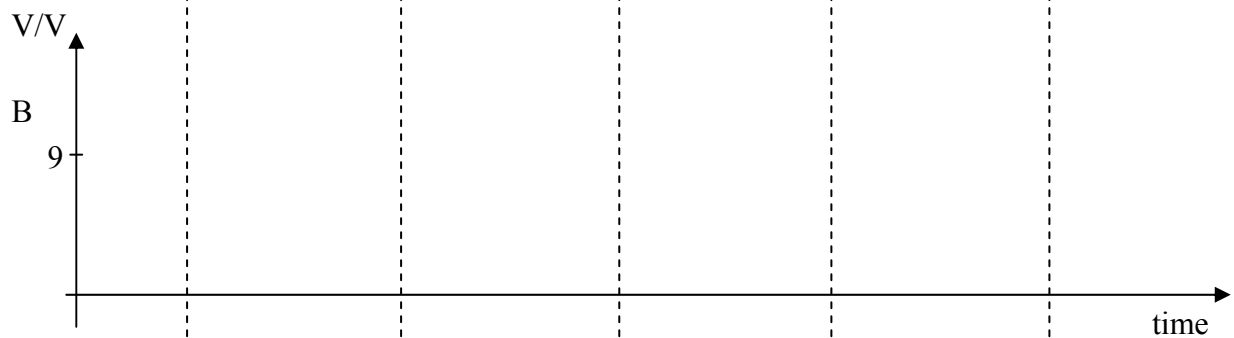
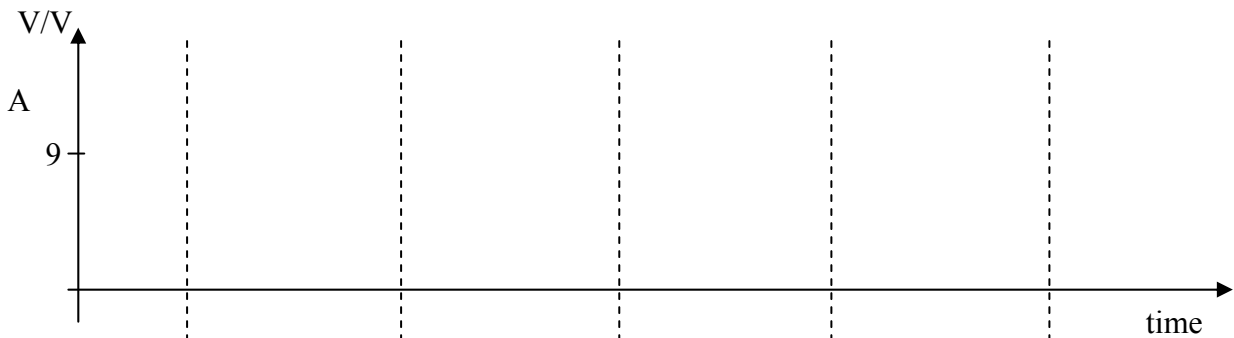
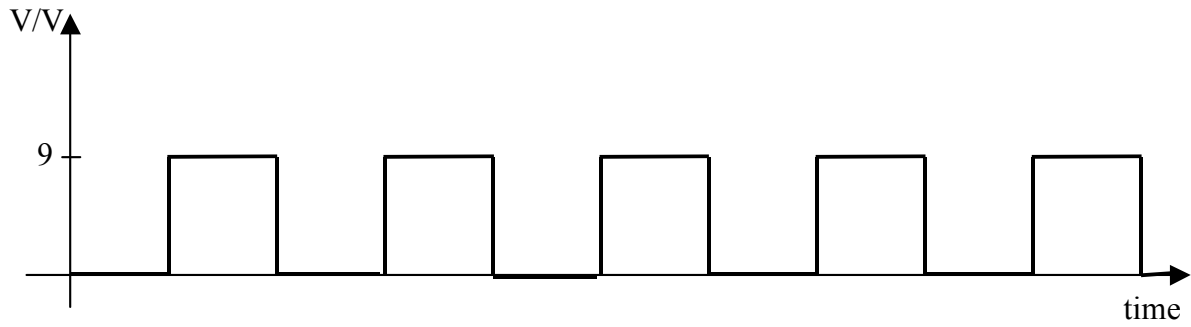

(6 marks)

- 9 (d) (ii) The heater, stirrer and pump are each switched on when a high voltage from the counter is supplied to their driver circuits. State the sequence of events which happen as the 555 produces the pulses shown above.

.....

.....

(3 marks)

- 10** Many drinks bottling plants run continuously. A controlled supply of water to the bottling unit is essential to maintain production. The water storage tank in a bottling plant has two sensors, S_1 and S_2 .

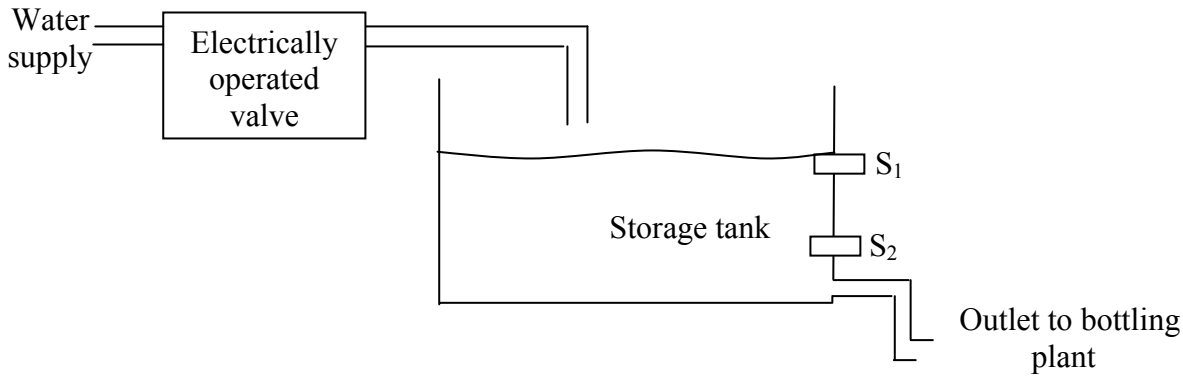

The sensors are different. S_1 gives a high output when in water and a low output when it is dry. S_2 is the opposite; it gives a high output when it is dry and a low output when in water. The sensors are connected to a D-type flip-flop which is used to open and close the valve to maintain the correct level in the storage tank.

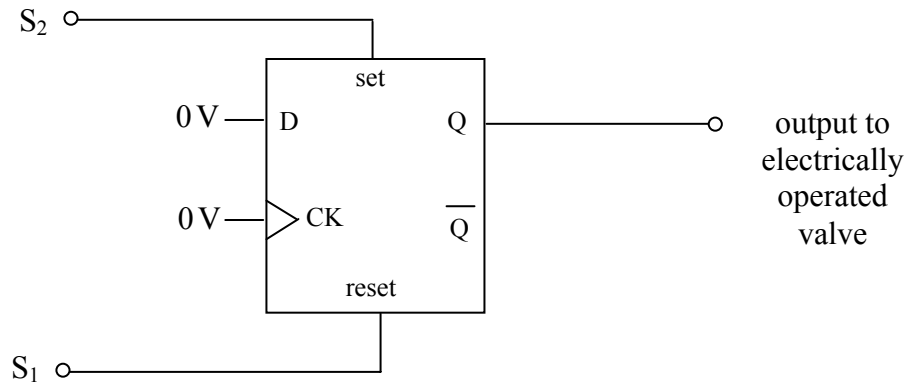

The valve opens when the Q output of the flip-flop is high.

- 10** (a) The valve is closed and then water is run from the storage tank until the level falls below S_2 . Explain the sequence of events starting with S_2 being uncovered.

Answer this question in continuous prose, the quality of written communication will be assessed in your answer.

.....

.....

.....

.....

.....

.....

.....

(5 marks)

Question 10 continues on the next page

Turn over ►

- 10** (b) (i) Complete this circuit diagram to show how a MOSFET can be connected as a driver to operate the valve. Label the connections to the MOSFET.

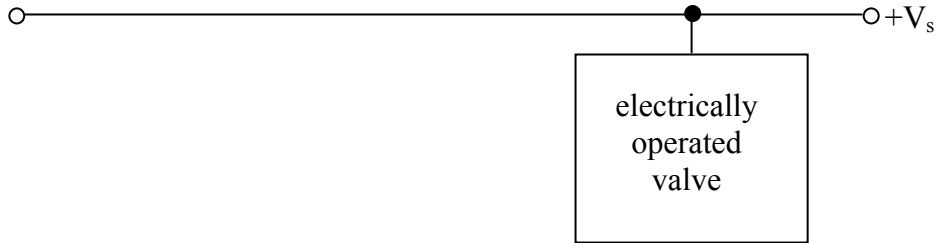

Q output of flip-flop

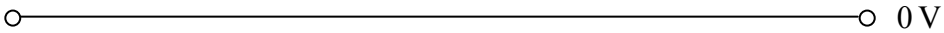
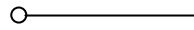

(3 marks)

- 10** (b) (ii) The electrically operated valve contains a motor so a diode must be connected in parallel with it. Show this diode on the circuit diagram above.

(2 marks)

- 10** (b) (iii) Explain why the diode is needed.

.....

.....

.....

.....

(2 marks)

- 10 (c) An engineer wants to add an alarm to the water system to warn if it is freezing. He decides to use a thermistor as a temperature sensor.

He firstly needs to measure the resistance of the thermistor at 0 °C.

Complete the circuit diagram to show how the engineer should connect a voltmeter and an ammeter to calculate the resistance of the thermistor.

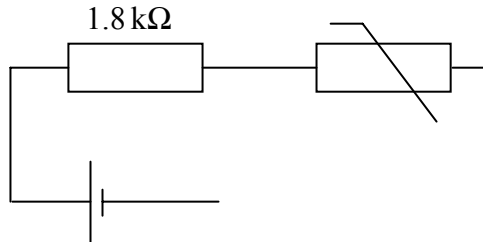

(4 marks)

- 10 (d) The ammeter reads 0.5 mA. What is this current in amps?

.....
(1 mark)

- 10 (e) If the voltmeter reads 0.40 V, calculate the resistance of the thermistor.

.....
.....
(2 marks)

- 10 (f) Complete the circuit diagram below drawing the thermistor and another fixed resistor connected so that the output will be high when cold and low when hot.

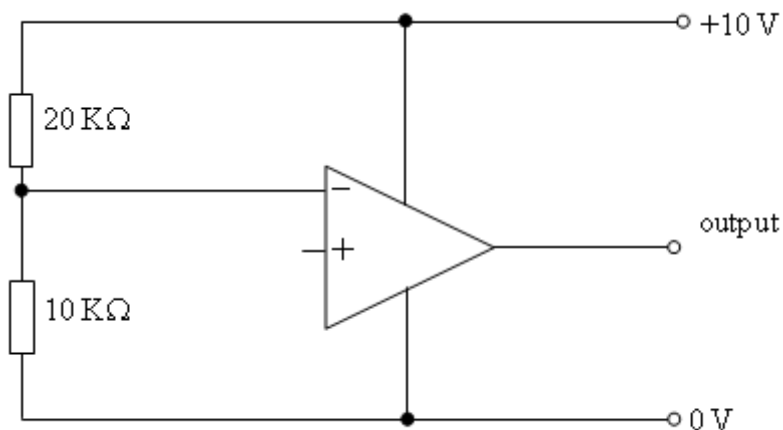

(2 marks)

Question 10 continues on the next page

Turn over ►

- 10** (g) Calculate a suitable value for the fixed resistor if the output is to go from low voltage to high voltage when the temperature falls below 0°C .
Use the value for the thermistor's resistance from part (e).

.....
.....

(2 marks)

23

END OF QUESTIONS

Mark Scheme**Question 1**

- 1 (a) Any five dangers from:
 working alone
 working on mains powered circuit
 circuit live/plugged in
 no earth
 capacitor charged across mains incorrectly polarised
 water near mains supply
 soldering iron danger ✓✓✓✓✓ (5 max)
 (5 marks)
- 1 (b) shock related effect✓
 burn related effect✓
 (2 marks)
- 1 (c) remove victim from mains✓ put in recovery position✓ resuscitation✓
 get help✓ (max 3)
 (3 marks)

Total Mark: 10**Question 2**

- 2 (a) (i) temperature sensor✓
 (1 mark)
- 2 (a) (ii) heater✓
 (1 mark)
- 2 (a) (iii) comparator✓
 (1 mark)
- 2 (b) (i) comparator✓
 (1 mark)
- 2 (b) (ii) temperature sensor✓
 (1 mark)
- 2 (c) transistor switch✓ electromagnetic relay✓ (any order)
 (2 marks)
- 2 (d) comparator output goes high (or changes) ✓
 transistor switches relay ✓
 relay switches on✓
 heater switches on✓
 (max 3)
 (3 marks)

Total Mark: 10

Question 3

- 3 (a) OR✓
AND✓
NAND✓

(3 marks)

- 3 (b)

A	B	C	D	Q
0	0	0	1	0
0	1	1	1	1
1	0	1	1	1
1	1	1	0	0
		✓	✓	✓

(6 marks)

- 3 (c)

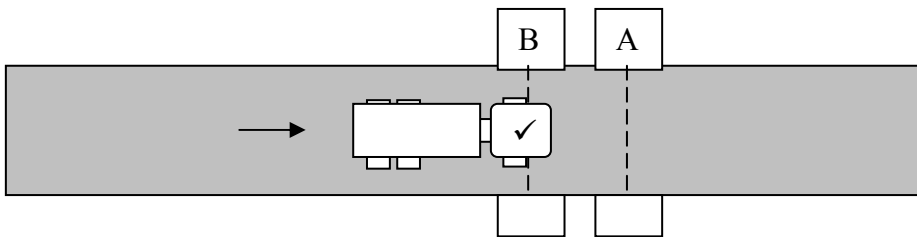

(1 mark)

Total Mark: 10

Question 4

- 4 (a) capacitor✓
470 microfarads✓
16V✓
polarity✓

(4 marks)

- 4 (b) resistor✓
47✓000✓Ω✓
5%✓
to limit current✓

(6 marks)

Total Mark: 10

Question 5

- 5 (a) 7 V ✓ (1 mark)
- 5 (b) $R = V/I = 7/0.2 = 350 \Omega$ ✓ (2 max) (2 marks)
- 5 (c) (i) 360 Ω ✓ (1 mark)
- 5 (c) (ii) orange ✓ blue ✓ brown ✓ gold ✓ (4 marks)

Total Mark: 8**Question 6**

- 6 (a) CD player in correct position ✓, tuner in correct position ✓, amplifier in correct position ✓, speakers in correct position ✓ (4 marks)
- 6 (b) (i) tuned circuit ✓ selects ✓ (one) frequency ✓ (3 marks)
- 6 (b) (ii) demodulator ✓ separates ✓ the signal from the carrier wave ✓ (3 marks)
- 6 (c) can distinguish signals ✓ which have frequencies close to each other ✓ (2 marks)
- 6 (d) (i) frequency modulation ✓ (1 mark)
- 6 (d) (ii) amplitude modulation ✓ (1 mark)
- 6 (e)

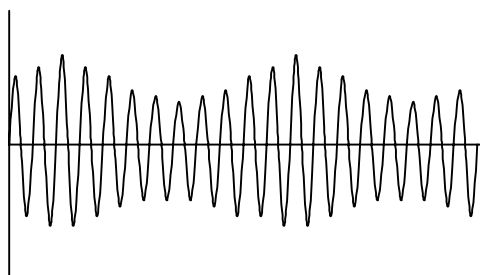

correct shape ✓ approx. in phase with audio ✓

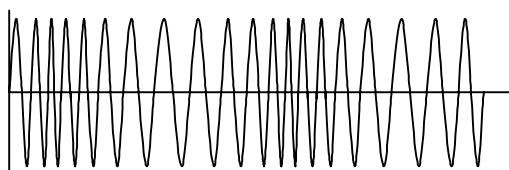

correct shape ✓ approx. in phase with audio ✓

(4 marks)

Total Mark: 18

Question 7

7 (a)

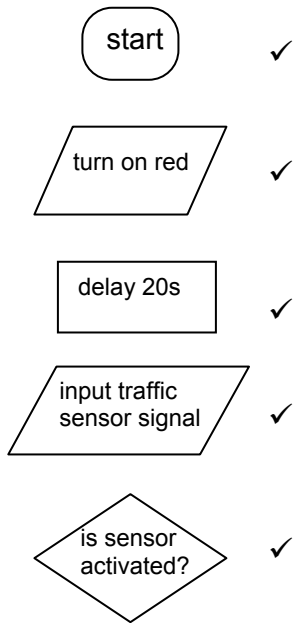

(5 marks)

7 (b)

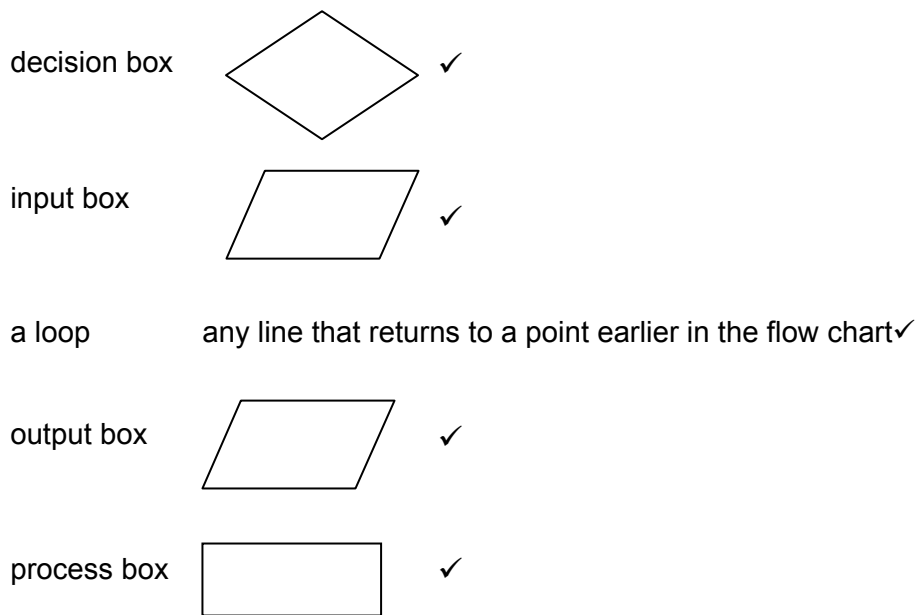

(5 marks)

7 (c)

(i) 23s ✓

(1 mark)

7 (c)

(ii) green on for 10s longer ✓

(1 mark)

7 (c)

(iii) 2 ✓

(1 mark)

7 (c)

(iv) 6s ✓

(1 mark)

7 (c)

(v) 56s ✓

(1 mark)

7 (d)

The marking scheme for this part of the question includes an assessment of the Quality of Written Communication (QWC). There are no discrete marks for the assessment of written communication but QWC will be one of the criteria used to assign the answer to an appropriate level below.		
Level	Marks	Descriptor an answer will be expected to meet most of the criteria in the level descriptor
3	4-5	<ul style="list-style-type: none"> - answer is full and detailed and is supported by an appropriate range of relevant points such as those given below - argument is well structured with minimal repetition or irrelevant points - accurate and clear expression of ideas with only minor errors in the use of technical terms, spelling, punctuation and grammar
2	2-3	<ul style="list-style-type: none"> - answer has some omissions but is generally supported by some of the relevant points below - the argument shows some attempt at structure - the ideas are expressed with reasonable clarity but with a few errors in the use of technical terms spelling, punctuation and grammar
1	0-1	<ul style="list-style-type: none"> - answer is largely incomplete, it may contain some valid points which are not clearly linked to an argument structure - unstructured answer - errors in the use of technical terms, spelling, punctuation and grammar or lack of fluency
		<p>An example of the type of answer that may be produced would be:</p> <p>The traffic sensor signal is read and not activated leading to the short delay of 20s before the green light is switched off and the amber light is switched on.</p> <p>There is then a delay of 3s before the amber light is switched off and the red light is switched on.</p> <p>After a further 20s delay the amber light is switched on again for 3s before both amber and red lights are switched off when the green light is switched on again and cycle is repeated.</p>

*(5 marks)***Total Mark: 20**

Question 8

8 (a) (i) A cannot break the beam to S1 without also breaking beam to S2 and S3 ✓

(1 mark)

8 (a) (ii)

	1	1	1	0
	1	1	0	1
	1	0	0	0
	0	0	0	1
	✓	✓	✓	✓

(4 marks)

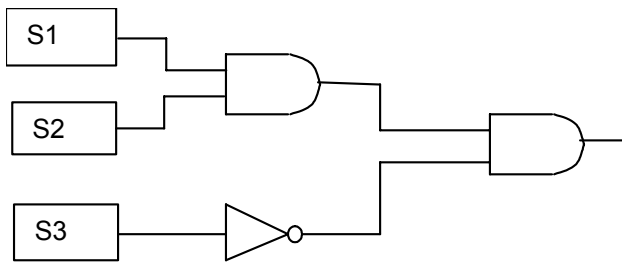

8 (a) (iii) S1 to AND gate ✓
 S2 to same AND gate ✓
 S3 to NOT gate ✓
 Both outputs to another AND gate ✓

(4 marks)

8 (b) (i)

		1	1	0
		1	0	0
		0	1	0
		0	0	1
		✓	✓	✓

(3 marks)

8 (b) (ii)

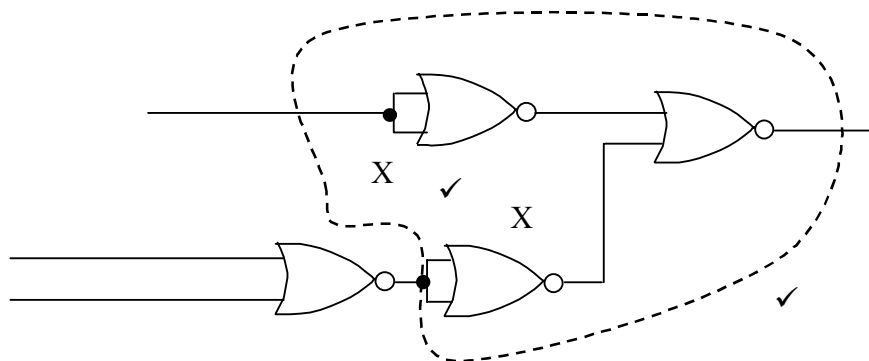

(2 marks)

8 (b) (iii)

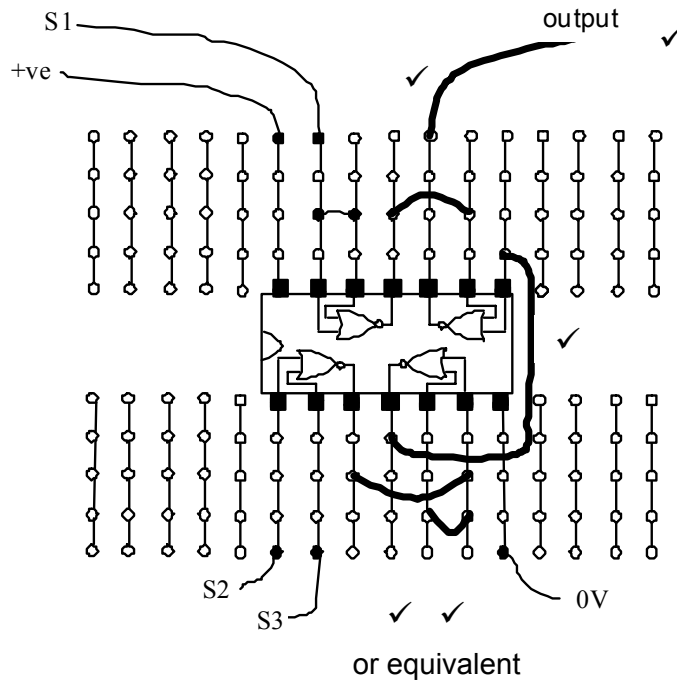

(5 marks)

Total Mark: 19

Question 9

9 (a)

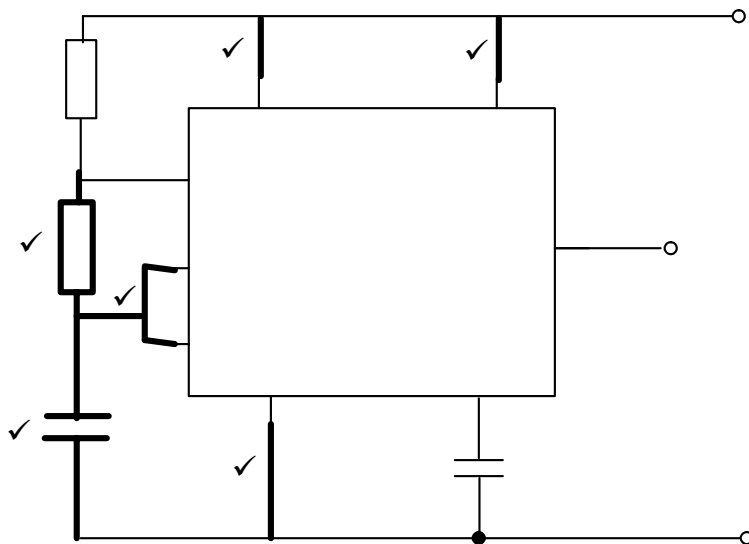

(6 marks)

9 (b) $T = (R_1 + 2R_2)C / 1.44 = 31 \text{ s}$

(3 marks)

9 (c) (i)

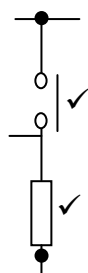

(2 marks)

- 9 (c) (ii) pull down resistor✓, to hold the voltage low✓ when the switch is not pressed✓ (2 max)

(2 marks)

- 9 (d) (i)

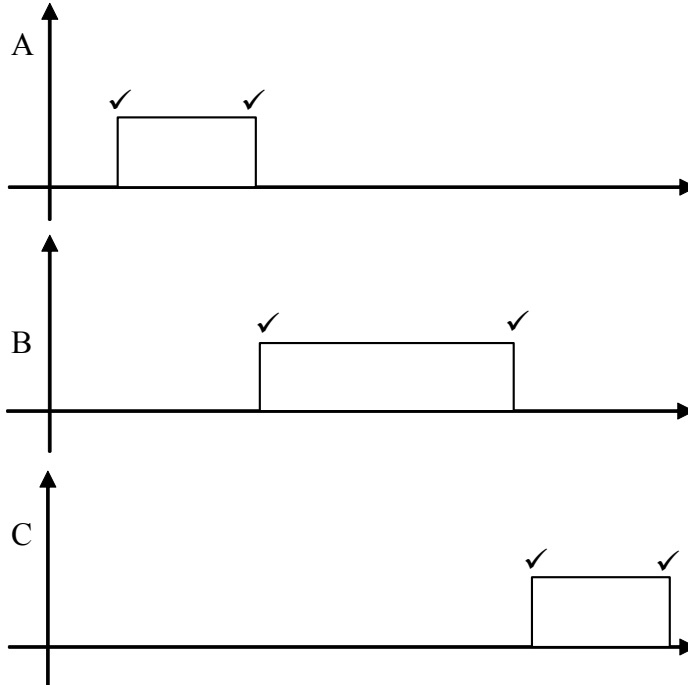

(6 marks)

- 9 (d) (ii) heater comes on (for half minute)✓
 then stirrer comes on (for one minute)✓
 pump comes on (for half minute)✓

(3 marks)

Total Mark: 22

Question 10

10 a)

The marking scheme for this part of the question includes an assessment of the Quality of Written Communication (QWC). There are no discrete marks for the assessment of written communication but QWC will be one of the criteria used to assign the answer to an appropriate level below.		
Level	Marks	Descriptor
		an answer will be expected to meet most of the criteria in the level descriptor
3	4-5	<ul style="list-style-type: none"> - answer is full and detailed and is supported by an appropriate range of relevant points such as those given below - argument is well structured with minimal repetition or irrelevant points - accurate and clear expression of ideas with only minor errors in the use of technical terms, spelling, punctuation and grammar
2	2-3	<ul style="list-style-type: none"> - answer has some omissions but is generally supported by some of the relevant points below - the argument shows some attempt at structure - the ideas are expressed with reasonable clarity but with a few errors in the use of technical terms spelling, punctuation and grammar
1	0-1	<ul style="list-style-type: none"> - answer is largely incomplete, it may contain some valid points which are not clearly linked to an argument structure - unstructured answer - errors in the use of technical terms, spelling, punctuation and grammar or lack of fluency
		<p>An example of the type of answer that may be produced would be:</p> <p>The sensor S_2 gives a high output which causes output Q from the flip-flop to go high.</p> <p>The electrically operated valve opens and water flows into the tank until the sensor S_1 is covered. (The output of sensor S_2 becomes low but this does not affect the output of the flip-flop.)</p> <p>The sensor S_1 gives a high output which resets the flip-flop, meaning that its output Q is low, so the electrically operated valve stops the flow of water.</p>

(5 marks)

10 (b) (i) & (ii)

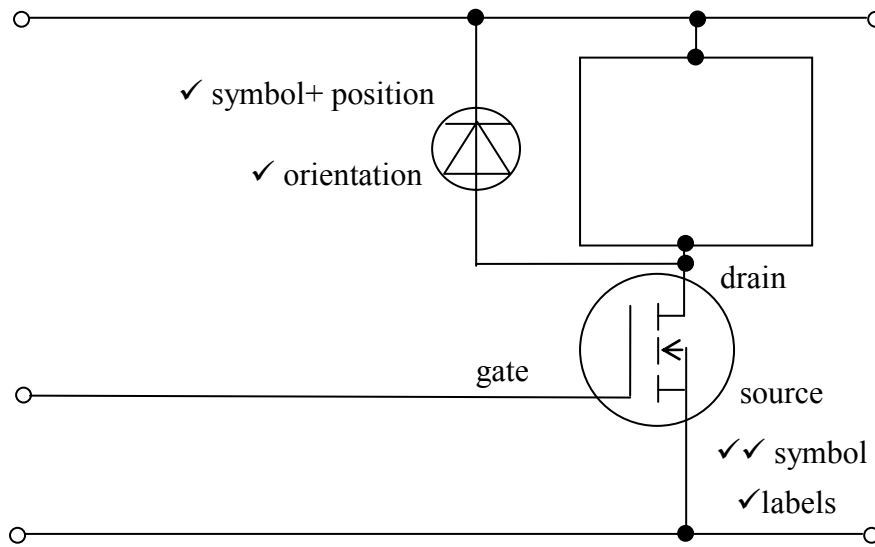

(5 marks)

10 (b) (iii) to protect the MOSFET ✓
 from high voltages ✓
 (induced) when the motor is switched off ✓ (Max 2)

(2 marks)

10 (c)

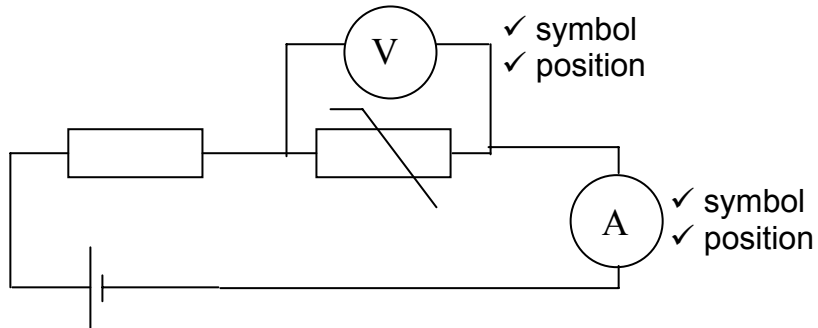

(4 marks)

10 (d) 0.0005 A ✓

(1 mark)

10 (e) $R = V/I = 0.4/0.0005 \checkmark = 800 \checkmark \Omega \checkmark$ (2 max)

(2 marks)

10 (f)

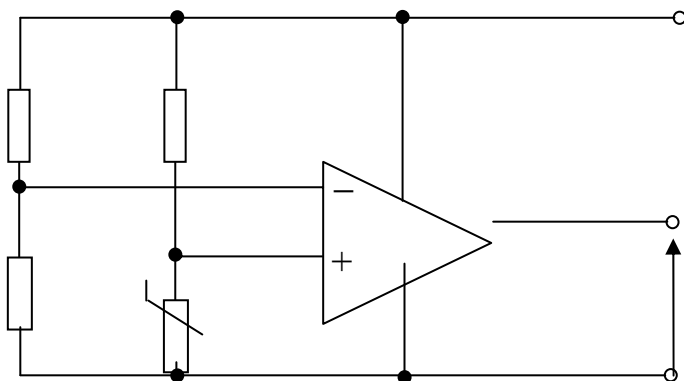

potential divider to non-inverting input ✓
 thermistor in correct position ✓

(2 marks)

10 (g) 1600Ω ✓✓

(2 marks)

Total Mark: 23

Paper Total: 150

This page is intentionally blank