

Surname	Centre Number	Candidate Number
Other Names		0



GCSE

4101/01



S15-4101-01

DESIGN AND TECHNOLOGY

UNIT 1

FOCUS AREA: Graphic Products

A.M. TUESDAY, 19 May 2015

2 hours

For Examiner's use only		
Question	Maximum Mark	Mark Awarded
Section A	1.	15
	2.	10
	3.	10
	4.	25
Section B	5.	10
	6.	15
	7.	20
	8.	15
Total	120	

ADDITIONAL MATERIALS

You will need basic drawing equipment, coloured pencils and a calculator for this examination.

INSTRUCTIONS TO CANDIDATES

Use black ink or black ball-point pen.

Write your name, centre number and candidate number in the spaces at the top of this page.

Answer **all** questions.

Write your answers in the spaces provided in this booklet. Where the space is not sufficient for your answer, continue at the back of the book, taking care to number the continuation correctly.

You are reminded of the necessity for good English and orderly presentation in your answers.

INFORMATION FOR CANDIDATES

The number of marks is given in brackets at the end of each question or part-question.

Section A

Marked out of 60 60 minutes

1. This question is about Product Analysis. It is worth a total of 15 marks.

The photographs below show details of a box for a mail order healthy eating company. The questions that follow are about the box.



Closed box



Open box, with internal colour images



Card inlay



Box net

- The box is available in one size.
- The box contains four healthy snacks that are held in place by the card inlay.
- The box is printed on both sides, a full colour image on the inside.
- The structure is completely glueless.

(a) (i) Complete the table below to give the reasons for the specification point. [2]

The first specification point has been done for you.

Specification point	Reasons
The box size must be 245mm x 165mm x 25mm.	The box size allows enough space for the contents to be packaged comfortably without being squashed, whilst not wasting too much excess material.
The box material must be 280 gsm.	<p>.....</p> <p>.....</p> <p>.....</p> <p>.....</p>

(ii) Give **two** reasons why the card inlay is made from a smaller gsm material than the box. [2]

Reason 1:

Reason 2:

(b) Study the information in the table below and state what is the best material to use for the box.

<i>Material</i>	<i>Glassine Paper</i>	<i>Non-Recycled Bleached Duplex Paperboard.</i>
<i>Properties</i>	<ul style="list-style-type: none"> • Strong and durable yet light. • Can be printed on one side. • Easy to fold and glue. • Greaseproof and resistant to water at first. • Loses resistance to water easily and quickly. 	<ul style="list-style-type: none"> • Strong and durable. • Available in a variety of different weights. • Can be printed on both sides. • One side is duller than the other. • It is safe to come into contact with food.

(i) Name of the material: [1]

(ii) Explain why the boxes are **not** made from recycled material. [2]

.....

.....

.....

(iii) Explain why the company use glueless nets for their boxes. [2]

.....

.....

.....

4101
010003

- (c) The mail order company includes paper based advertising with nutritional information and some accessories in their snack box.



Personalised welcome booklet including nutritional information and vouchers.



Paper napkin which is part of an accessories pack.

Explain why it is important for the company to include such items in their boxes. [3]

.....

.....

.....

.....

(d) The advert below shows the company's special offer that attempts to attract potential customers into purchasing their product. The questions that follow are about the advert.

SPECIAL OFFER!

- Your first box **half** of the original price
- Your next 2 boxes for $\frac{3}{4}$ of the full price
- Your other boxes Cost **£3.80** (full price)

over 100 snacks, each with a healthy benefit

every box made especially for you

delivered to your work or home

(i) State how much the first box would cost. [1]

.....

(ii) Calculate the total cost of 7 boxes. [2]

(Show all your workings.)

.....

.....

.....

.....

2. This question is about the general issues of Design & Technology. It is worth a total of 10 marks.

(a) Before designing a product, designers will assess the environmental impact of a product.

(i) State the name of that process illustrated below. [3]



L C A

(ii) The Committee for European Standardisation (CEN) sets standards and technical specifications for products made and sold in Europe.



Name **two** organisations that the CEN works closely alongside. [2]

Name 1: Name 2:

(b) The following symbols are often used on graphic products.



Explain how these symbols have encouraged consumers to think about sustainable and environmental issues. [2]

.....
.....
.....

(c) The Packaging (Essential Requirements) Regulations 2003, are a set of criteria that affect how designers think about packaging and packaging design.

List **three** areas of packaging design that are affected by the regulations. [3]

- 1.
- 2.
- 3.

4. This question is about the Design Process and how it is used. It is worth a total of 25 marks.

(a) (i) Using words from the list below, complete the table to match the stages of the design process with their description. [4]

Specification Evaluation Design Brief Planning Development

<i>Process</i>	<i>Description</i>
.....	A list of criteria for the product.
.....	Testing and comparing your product to the design specification.
.....	A statement outlining the aims of your project.
.....	Refining and improving your ideas.

(ii) State the name of the activity that involves a designer finding out what customers require in a product. [1]

.....

(b) Explain why it is important to plan the manufacture of products carefully. [3]

.....

(c) A greeting card company is releasing a range of pop-up cards. They have asked you to design a prototype card for their consideration.

The company states that:

- your card must be a pop-up birthday card for a child aged 4-6;
- your design should suit the stated target audience.

Design your **front** cover in the space provided.

Marks will be awarded for:

- (i) an interesting, full colour design for the front of the pop-up card; [4]
- (ii) using an innovative finishing process to the front of the pop-up card. [1]

State the innovative finishing process that is to be used on the front of your pop-up card.

.....

Draw your design for the **inside** of the pop-up card in the space provided below.

Marks will be awarded for:

- (iii) an innovative solution for the **inside** of your pop-up card; [3]
- (iv) a fully detailed annotated sketch of the pop-up mechanism; [5]
- (v) the quality of the drawing and presentation. [4]

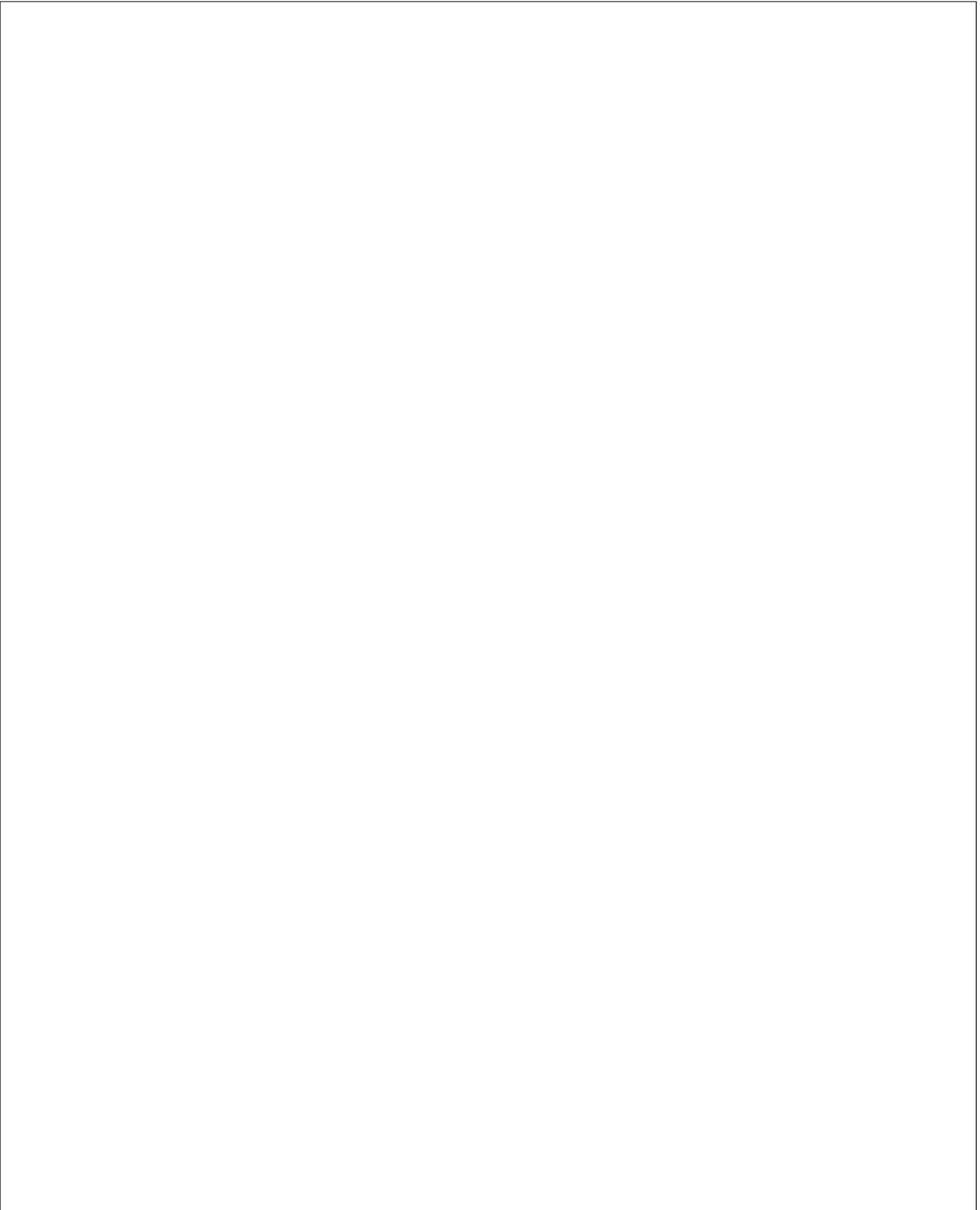

Section B

Marked out of 60 60 minutes

5. This question is about Commercial Manufacturing Processes. It is worth a total of 10 marks.



(a) (i) Name the **three** stages in commercial printing. [3]

Stage 1:

Stage 2:

Stage 3:

(ii) Complete the table below by stating the correct name for **each** process 3 × [1]

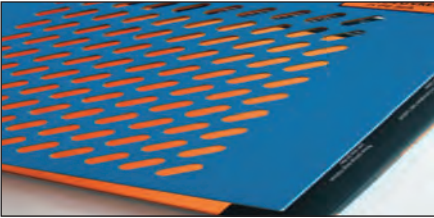
Process	Name
 <p>The process that allows for parts of the design to be sunken into the surface of the material.</p>	<p>.....</p> <p>.....</p>
 <p>The process that allows part of the design to have a gloss finish whilst leaving the remainder matt.</p>	<p>.....</p> <p>.....</p>
 <p>The process that allows part of the material to be removed.</p>	<p>.....</p> <p>.....</p>

(b) Explain how the following symbols and marks are used on printed graphics.



Registration Marks

(i)
.....
..... [2]

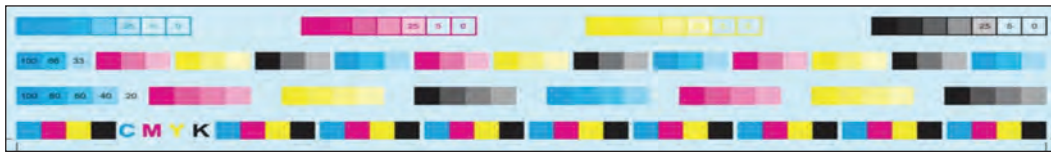

Colour Bars showing CMYK %

(ii)
.....
..... [2]

6. This question is about Materials and Components. It is worth a total of 15 marks.

(a) List the following paper sizes in order from smallest to largest. [3]

A6 **A0** **A2**

Smallest:

.....

Largest:

(b) (i) State the name of the colour scheme illustrated by the colour wheels below. [1]



Colour scheme:

(ii) Place a tick (✓) in the box under the illustration that best represents a colour gamut. [1]

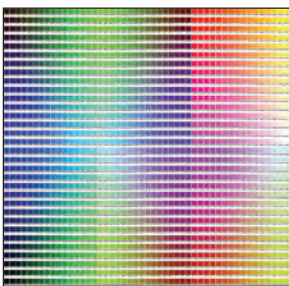

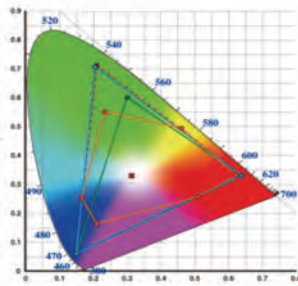

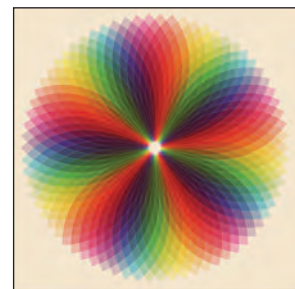

(iii) Colour systems can be either additive or subtractive. Describe the difference between an additive colour system and a subtractive colour system. [3]

.....

.....

.....

.....

(c) (i) Using the list below, match the correct material to **each** description. 2 × [1]

Olfactory Packaging Slow Release Patch Tamper-Indicating Wrapper

<i>Material</i>	<i>Description</i>
<p>.....</p> <p>.....</p>	<p>Scented and aromatic oils are embedded into labels, plastic or printing ink that release scent. Some technologies require touch for the scent to be released.</p>
<p>.....</p> <p>.....</p>	<p>A laminated material that allows the consumer to identify if the material has been damaged. A visible change to the layers will indicate if the package or the contents have been interfered with.</p>

(ii) Explain what you understand by the term ‘composite materials’. [2]

.....

.....

.....

(d) Typography is either legible or readable.

This is an example of legible text. There are many differences between the legibility and readability of words. This is an example of legible text. There are many differences between the legibility and readability of words.

LEGIBLE TEXT

This is an example of readable text. There are many differences between the legibility and readability of words. This is an example of readable text. There are many differences between the legibility and readability of words.

READABLE TEXT

Describe the difference between legible and readable text. [3]

.....

.....

.....

.....



7. This question is about Tools, Equipment and Making. It is worth a total of 20 marks.

(a) Name the shape that the tool illustrated helps designers make. [1]

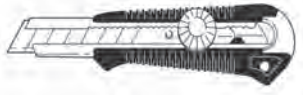

Shape:

(b) (i) Complete the table below by describing the safety feature of **each** of the tools/equipment shown.

<i>Tool/Equipment</i>	<i>Safety Feature</i>
 <p>Craft knife with retractable snap-off blades.</p>	<p>.....</p> <p>.....</p> <p>..... [2]</p>
 <p>Metal safety rule.</p>	<p>.....</p> <p>.....</p> <p>..... [2]</p>
 <p>Cutting mat.</p>	<p>.....</p> <p>.....</p> <p>..... [2]</p>

- (ii) The statements listed show the different stages in the production of the leaflet shown below. Complete the flowchart by placing the stages into the correct order. [6]

FLOWCHART

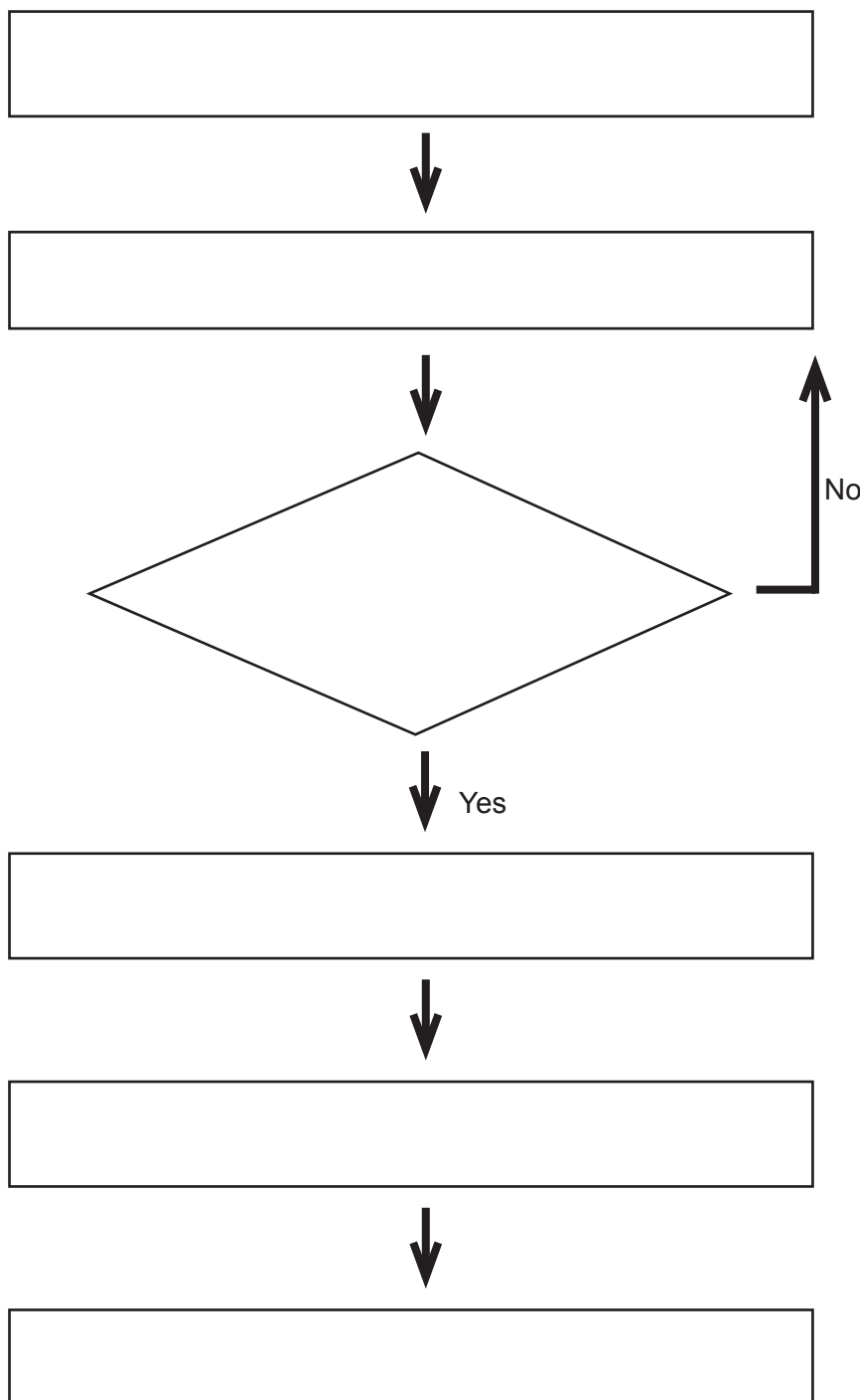

STAGES

- Does the document look as expected?
- Load printer with correct paper and click print.
- Create the document with correct fold lines and imposition.
- Score document and fold.
- Save document as a PDF (make any alterations).
- Cut out document safely.

(c) (i) State the function of the following tools when used in CAD packages. 3 × [1]



.....



.....



.....

(ii) Explain how adjusting the shutter speed on a digital SLR camera can help designers create different images. [2]

.....
.....
.....

(iii) Explain the meaning of the term duplex when related to graphic products. [2]

.....
.....
.....

8. This question is about ICT, CAD, CAM, Systems and Processes. It is worth a total of 15 marks.

(a) (i) State the correct name of **each** of the types of drawings below. [2]

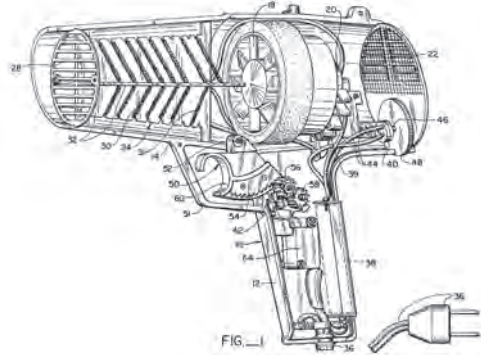
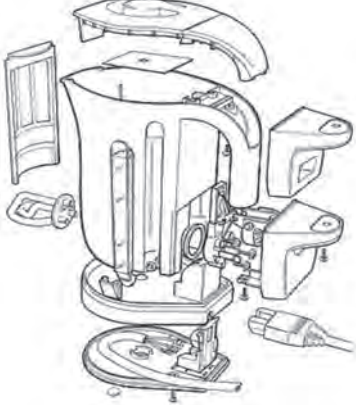

Name:

Name:

(ii) From the list below, state the correct name for **each** fold pictured. 3 × [1]

Barrel fold

Accordion fold

Gate fold

Parallel fold



Name:



Name:



Name:

- (b) Use drawing instruments to complete an isometric drawing of the shape below, in the space provided. Examiner only
 [4]
 Sizes are approximate and should be estimated.

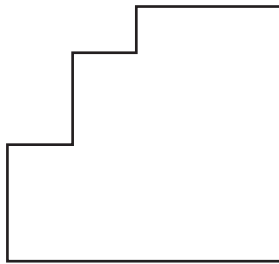
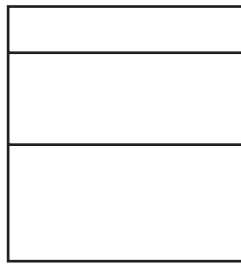
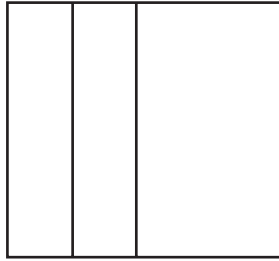
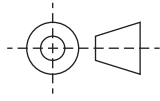

- (c) Complete the drawing below to construct an ellipse.
Marks will be awarded for showing all construction lines. The construction has been started for you.

Examiner
only

[6]

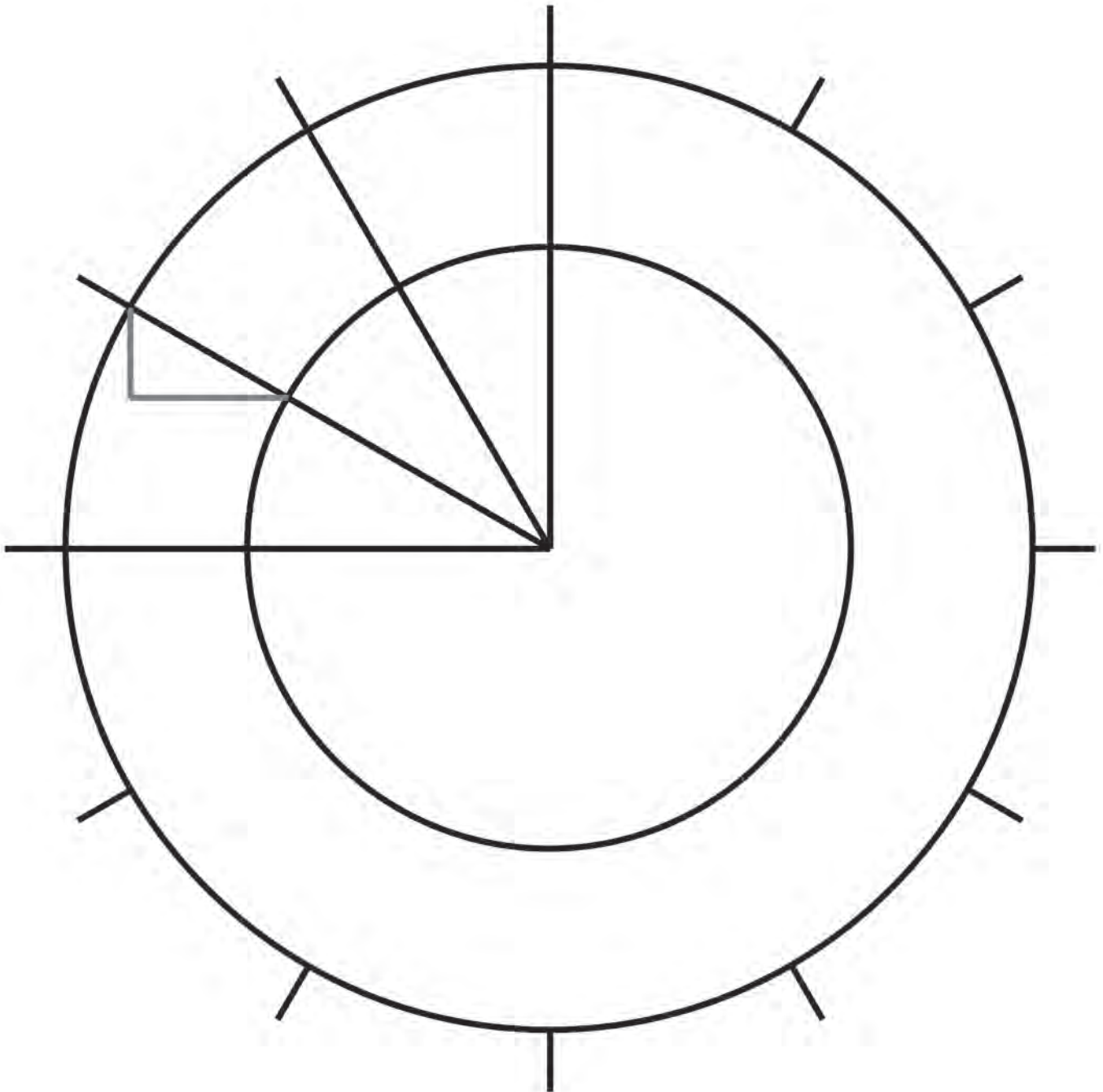
**END OF PAPER**

