

Surname
Other Names

Centre Number

Candidate Number
0



GCSE

4101/01

DESIGN & TECHNOLOGY

UNIT 1

FOCUS AREA: Graphic Products

A.M. WEDNESDAY, 15 May 2013

2 hours

	Leave Blank
Question 1	
Question 2	
Question 3	
Question 4	
Question 5	
Question 6	
Question 7	
Question 8	
TOTAL MARK	

ADDITIONAL MATERIALS

You will need basic drawing equipment, coloured pencils and a calculator for this examination.

INSTRUCTIONS TO CANDIDATES

Use black ink or black ball-point pen.

Write your name, centre number and candidate number in the spaces at the top of this page.

Answer **all** questions.

Write your answers in the spaces provided in this booklet. Where the space is not sufficient for your answer, continue at the back of the book, taking care to number the continuation correctly.

You are reminded of the necessity for good English and orderly presentation in your answers.

INFORMATION FOR CANDIDATES

The number of marks is given in brackets at the end of each question or part-question.

4101
010001

Section A

Marked out of 60 60 minutes

1. This question is about Product Analysis. It is worth a total of 15 marks.

The photograph below shows a collection box for a charity.
The questions that follow are about the collection box.



- The collection box is 300mm wide and 450mm long.
- The collection box is made from 500 micron folding boxboard.
- There is a secure section at the front of the collection box.

(a) State **one** reason why the charity has decided to manufacture the collection box to the sizes stated. [2]

.....

.....

.....

(b) Look at the photograph of the collection box and state, with as much detail as possible, why you think the following aspects of the design are important.

(i) The function of the collection box. [2]

.....
.....
.....

(ii) The security of the collection box. [2]

.....
.....
.....

(iii) The aesthetics of the collection box. [2]

.....
.....
.....

(c) State the most suitable scale of production for the manufacture of the collection box and give a reason why. [2]

Scale of production:

Reason:

.....

(d) Outline **one** important safety consideration of the product in terms of the person donating money. [2]

.....
.....
.....

4101
010003

- (e) The graph below shows the costs involved in producing the collection boxes. Study the graph and answer the questions that follow.

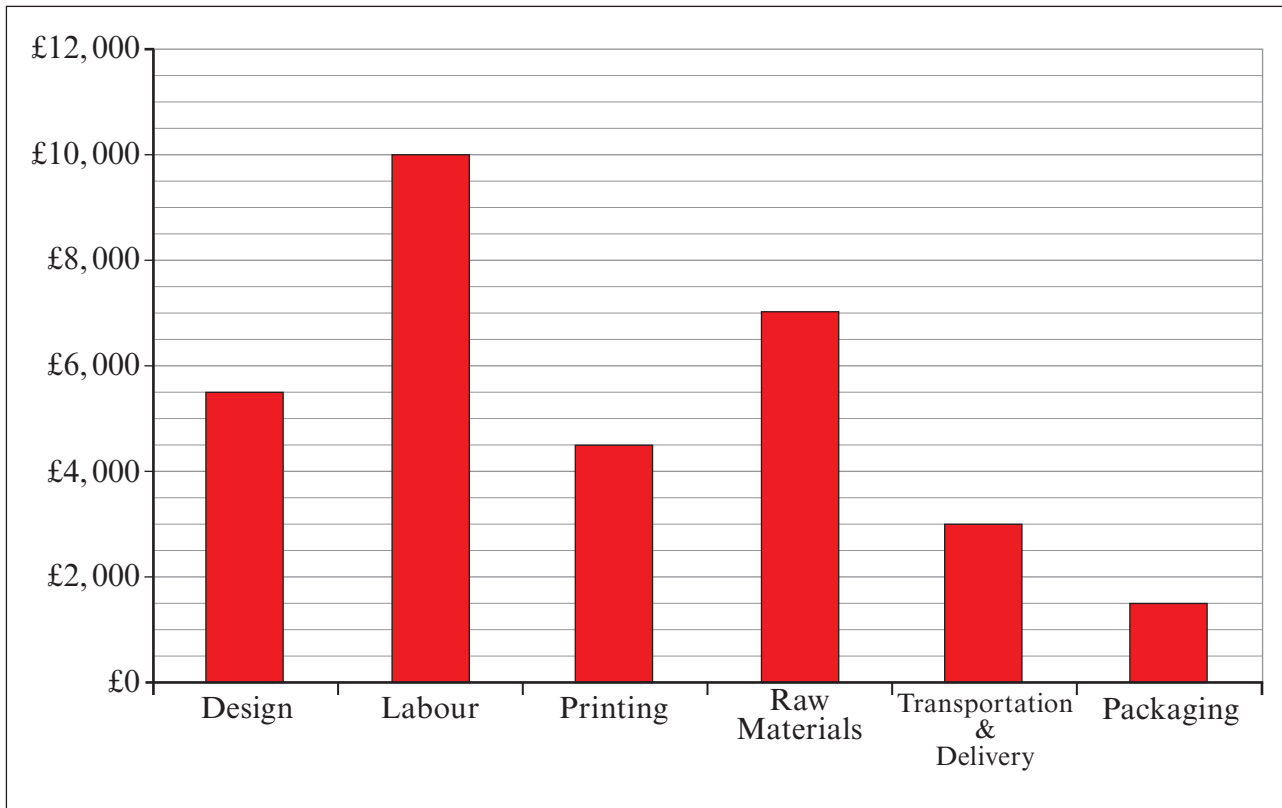

- (i) State the difference between the lowest cost and the highest cost. [1]

- (ii) Calculate the percentage (%) of the overall cost that transportation and delivery accounts for. [2]

Show all workings to **one** decimal place.

.....

.....

.....

.....

2. This question is about the general issues of Design and Technology. It is worth a total of 10 marks.

(a) Designers of sustainable products always use the principles of the six Rs.

(i) Use the words below to complete the list of the six Rs. [3]

RECYCLE RENOVATE REFUSE REPAIR RECONSTRUCT

- 1. RETHINK
- 2.
- 3. REUSE
- 4.
- 5.
- 6. REDUCE

(ii) Explain why a designer would undertake a life cycle analysis. [2]

.....

.....

.....

(b) (i) State which organisations use the following logos: [2]



.....



.....

(ii) Explain what the organisation CEN is responsible for. [3]

.....

.....

.....

.....

.....

.....

.....

.....

4. This question is about the Design Process and how it is used. It is worth a total of 25 marks.

(a) State the design stage that follows the two stages shown below. [1]

Design specification. Initial design ideas.

(b) (i) Explain why a designer writes a design specification before attempting to design a product. [2]

.....
.....
.....

(ii) Describe how a design specification helps a designer complete an evaluation of a product. [2]

.....
.....
.....

- (c) TiddlyWinks Nursery wishes to improve the information they send home to parents. A new report card system has been introduced to inform the parents of their child's progress at the nursery. The reports will be sent home in a new A5 card wallet.

A design for the wallet is needed. The design for the wallet must include:

- a suitable logo for TiddlyWinks Nursery;
- a wallet system that allows the report cards to be kept safe;
- a system that allows the wallet to be securely closed;
- a net for the wallet with dimensions.

- (i) Design a logo for the nursery that:

- uses **three** colours to keep printing costs low;
- uses the initials TW's as the basis for a simple logo;
- clearly conveys the nursery theme to the customer.

Marks will be awarded for:

- I. a simple logo that represents the nursery using the initial TW's;
- II. using **three** colours;
- III. the quality of the presentation drawing.

[2]
[1]
[2]

Draw your logo in the space provided.

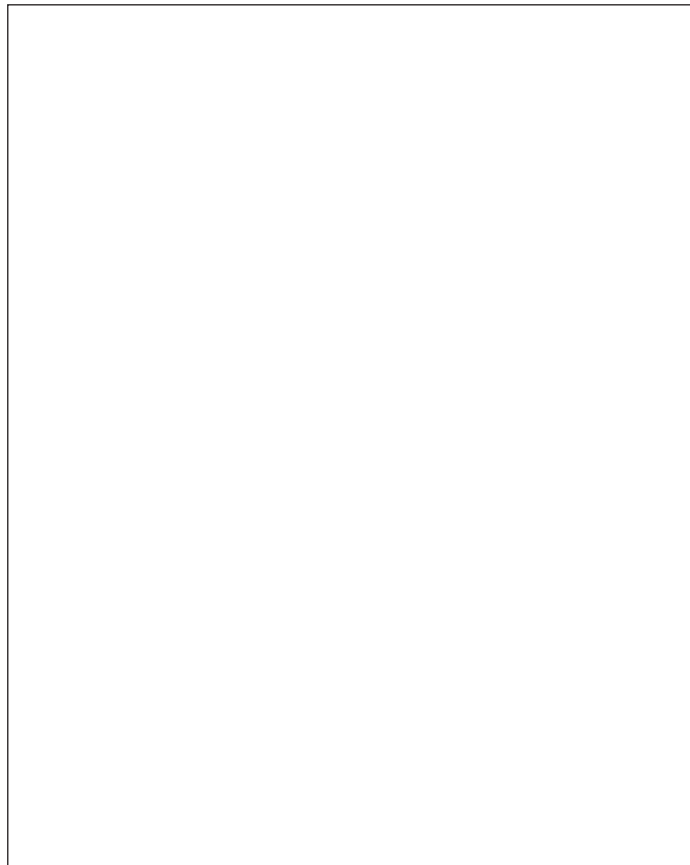

(ii) Design a cardboard wallet for the pupils to take their report cards home. The wallet must:

- hold the pupil's cards securely;
- have a locking mechanism;
- display the logo and name of the nursery.

Draw your solutions in the spaces provided.

Marks will be awarded for:

- | | |
|--|-----|
| I. showing the position of the TW's logo; | [1] |
| II. showing a method that holds the report cards in place; | [3] |
| III. showing overall sizes; | [2] |
| IV. developing an identity for the nursery; | [3] |
| V. showing the locking mechanism on the wallet; | [3] |
| VI. the quality of the communication. | [3] |

Your design for the wallet.

Your method for holding cards securely.

Your locking mechanism.

Section B

Marked out of 60 60 minutes

5. This question is about Commercial Manufacturing Processes. It is worth a total of 10 marks.

(a) (i) There are three stages in commercial printing. Fill in the missing words to complete the stages. [2]

1st Stage: Pre-Press

2nd Stage:

3rd Stage:

(ii) Explain what happens during the Pre-Press stage. [2]

.....
.....
.....

(b) Below are three processes involved in the commercial manufacturing process. Draw lines to join the processes to the correct description. [3]

Imposition	This process involves adding a liquid to a printed area, in order to highlight it.
Colour Separation	Arranging the pages of a document, so they fall in order, making printing easier and faster whilst minimising waste.
UV Varnishing	Splitting the artwork into their component hues before printing. Each is transferred to a plate; the plates become part of a process called Lithography.

(c) Below is an illustration of a commercial printing press.

(i) State the name of the process.

Name:

[1]

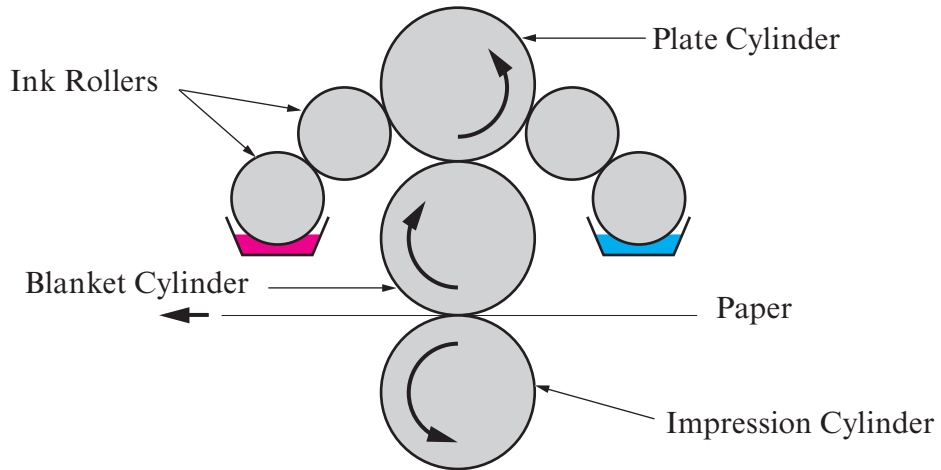

(ii) State **two** items that can be produced using this process.

Item 1:

[1]

Item 2:

[1]

6. This question is about Materials and Components. It is worth a total of 15 marks.

(a) (i) State **one** way the strength and finish of a paper can be improved. [1]

(ii) Paper is made on a Fourdrinier machine. It has four main sections. Study the image below and label the **three** remaining sections. [3]

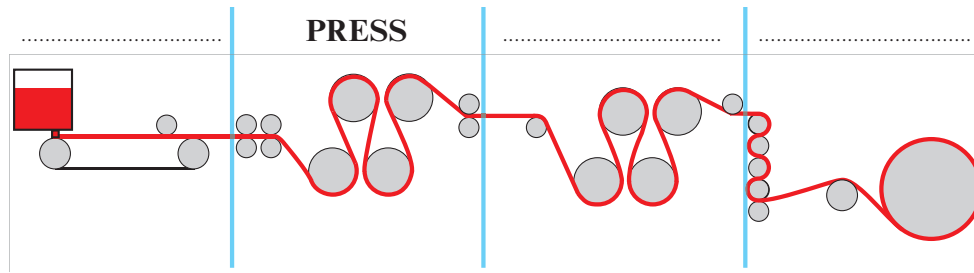

(iii) Describe what happens in the PRESS section. [3]

.....

.....

.....

.....

(b) (i) Typography is a key element of graphic design. Typefaces are made up of several component parts.



Complete the table below by naming the circled parts numbered 1, 2 & 3.

Number	Description	Name
1.	The name for the parts of letters that go above the x-height, on letters such as h. [1]
2.	The name for the parts of letters that drop below the baseline, on letters such as y and p. [1]
3.	The part of a letter added to the beginning and end of the main strokes of characters to add decoration on some typefaces. [1]

(ii) State the name given to the space between two lines of text.

[1]

.....

(c) The colour wheels below show two typical methods for creating a colour scheme.

(i) Name the methods illustrated.

[2]



Method:

Method:

(ii) Colours can be described as TINTS, TONES and SHADES.
Explain the difference between a TINT and a TONE.

[2]

.....

.....

.....

.....

.....

.....

.....

7. This question is about Tools, Equipment and Making. It is worth a total of 20 marks.

(a) Using the list, label the following fine line pens.

[4]

0.3, 0.8, 0.5, BM



.....

(b) (i) State the name of the drawing equipment shown below.

[1]



.....

(ii) Explain how templates can help a designer in their work.

[1]

.....

.....

.....

(c) Explain **two** safety considerations when finishing a prototype with spray paint.

Consideration 1: [2]

.....

.....

Consideration 2: [2]

.....

.....

(d) Explain what is meant by the following terms.

(i) Resolution: [2]

.....

(ii) Rollover Link: [2]

.....

(e) The image below shows a handmade prototype for a menu for a fast food outlet. The prototype was made out of 400 micron card.



Explain how the following steps would be done by hand.

Printing: [2]

.....

.....

Cutting out the menu: [2]

.....

.....

Scoring and folding: [2]

.....

.....

8. This question is about ICT, CAD, CAM, Systems and Processes. It is worth a total of 15 marks.

(a) (i) Data and graphics can be saved in many different formats. From the options below select the correct format for **each** task.

JPEG TIFF GIF HTML

Task	Format
Saving images, scripts or objects for publication on the web. This format allows web pages to function smoothly. [1]
Saving images and photographs, allowing for variations in colours and tones. Not suited to saving logos drawn using a vector based programme. [1]
Saving work that includes animations, for use on the web. Saving work in this bitmap image format may cause posterisation. [1]

(ii) State why it is important to use the correct format when saving work to be published on the internet. [2]

.....

.....

.....

(b) (i) Use drawing instruments to complete a 3rd Angle Orthographic Drawing of the shape drawn below. The drawing has been started for you. [6]

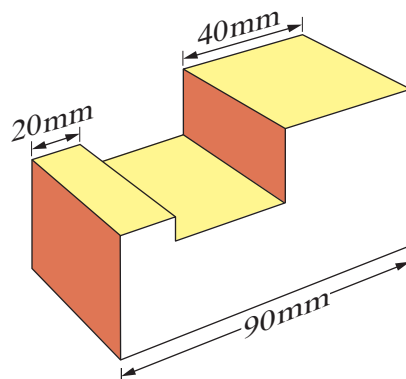

Show all construction lines.

Each grid square = 10mm

Front View

Each grid square = 10mm

- (ii) Shade your orthographic drawing to match the 3D view on the opposite page. [2]
- (iii) Add the correct symbol for the drawing. [2]



END OF PAPER

