

Candidate Name	Centre Number	Candidate Number

WELSH JOINT EDUCATION COMMITTEE  
General Certificate of Secondary Education



CYD-BWYLLGOR ADDYSG CYMRU  
Tystysgrif Gyffredinol Addysg Uwchradd

143/02

**DESIGN AND TECHNOLOGY**

**PAPER 2**

**FOCUS AREA: TEXTILES TECHNOLOGY**

(Foundation Tier – Grades G to C)

P.M. TUESDAY, 6 June 2006

(1½ hours)

	<b>Leave Blank</b>
<b>Question 1</b>	
<b>Question 2</b>	
<b>Question 3</b>	
<b>Question 4</b>	
<b>Question 5</b>	
<b>TOTAL MARK</b>	

**ADDITIONAL MATERIALS**

In addition to this examination paper you will need coloured pencils.

**INSTRUCTIONS TO CANDIDATES**

Write your name, centre number and candidate number in the spaces at the top of this page.

Answer **all** questions.

Write your answers in the spaces provided in this booklet. Where the space is not sufficient for your answer, continue the answer at the back of the book, taking care to number the continuation correctly.

**INFORMATION FOR CANDIDATES**

The number of marks is given in brackets at the end of each question or part-question.

No certificate will be awarded to a candidate detected in any unfair practice during the examination.

Answer **all** questions in the spaces provided.

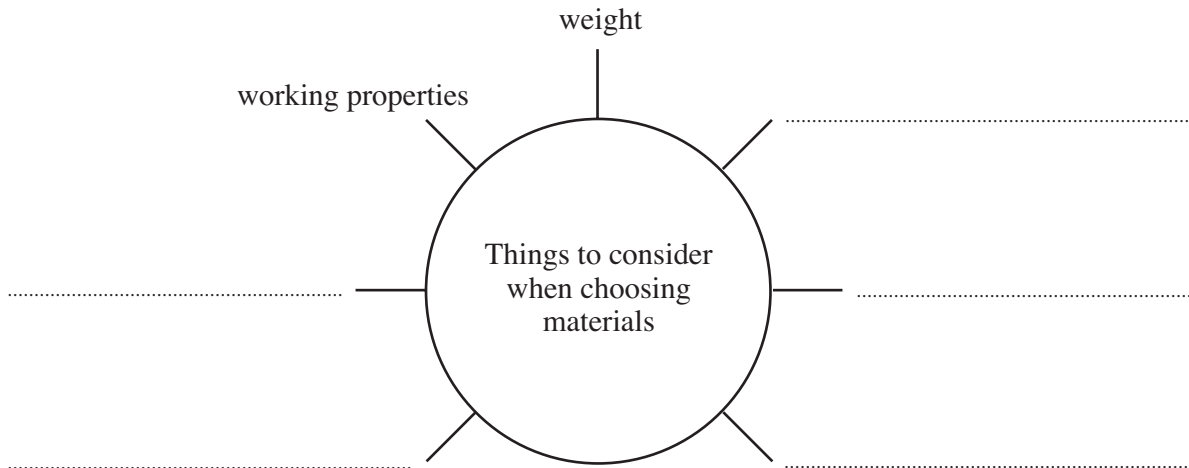

1. (a) **Complete** the diagram below by adding **five** things that you would consider when choosing the right material for a textile product. [5]

Two examples have been done for you.



- (b) For **each** textile product shown below, **state**:

- (i) the name of a suitable material to make the product; [3]
- (ii) the most important property that makes the material suitable for the product. [3]

Textile product	Name of material	Material property
 Bath towel	.....	.....
 Fleece jacket	.....	.....
 Swimwear	.....	.....

- (c) The graph below shows the strength of different textile *fibres*. **Study** the graph below and answer the questions that follow.

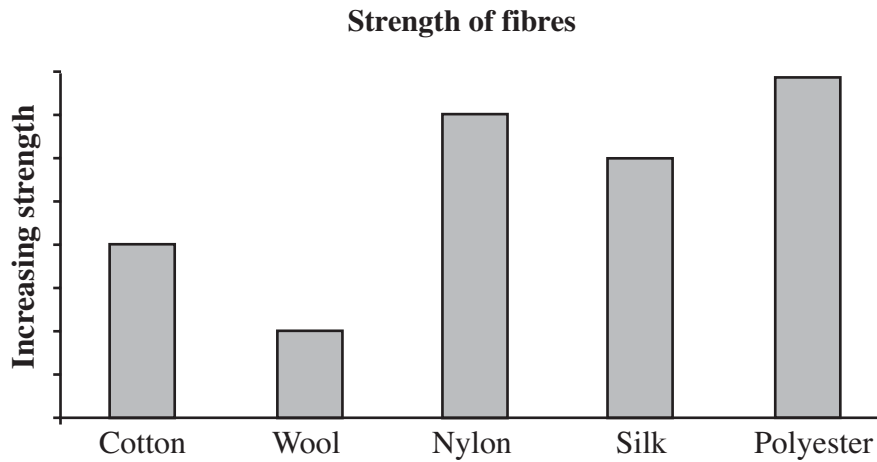

- (i) **State** the weakest fibre. [1]  
 .....
- (ii) **State** the strongest *synthetic* fibre. [1]  
 .....
- (d) **Describe one** method that can be used to make a yarn or textile material stronger and **give one** example of a yarn or textile material made stronger in this way.

Method: .....

..... [2]

Example of a yarn or material: .....

[1]

2. (a) Some *special finishes* given to textile materials are listed below.

**Anti-static**

**Proban**

**Raising**

**Mercerising**

**Complete** the table below by **matching** the special finish to its description.  
*An example has been completed for you.*

[3]

Special finish	Description
Anti-static	prevents the build up of static charge which makes synthetic clothes cling.
.....	gives a soft, fluffy texture to a material.
.....	makes cotton materials smooth and shiny.
.....	makes a material flameproof.

- (b) **Underline** the correct words to complete the sentences below:

[2]

- Cotton materials **burn easily** / **do not burn**.
- Nylon materials **do not absorb** / **do absorb** water.

(c) The picture below shows a design for a rucksack.



(i) The rucksack is made from *Cordura*. **State one** useful property of *Cordura*. [1]

.....

(ii) The layplan shown below can be used to work out the minimum length of material needed to make the rucksack. *Cordura* is 150 cm wide.

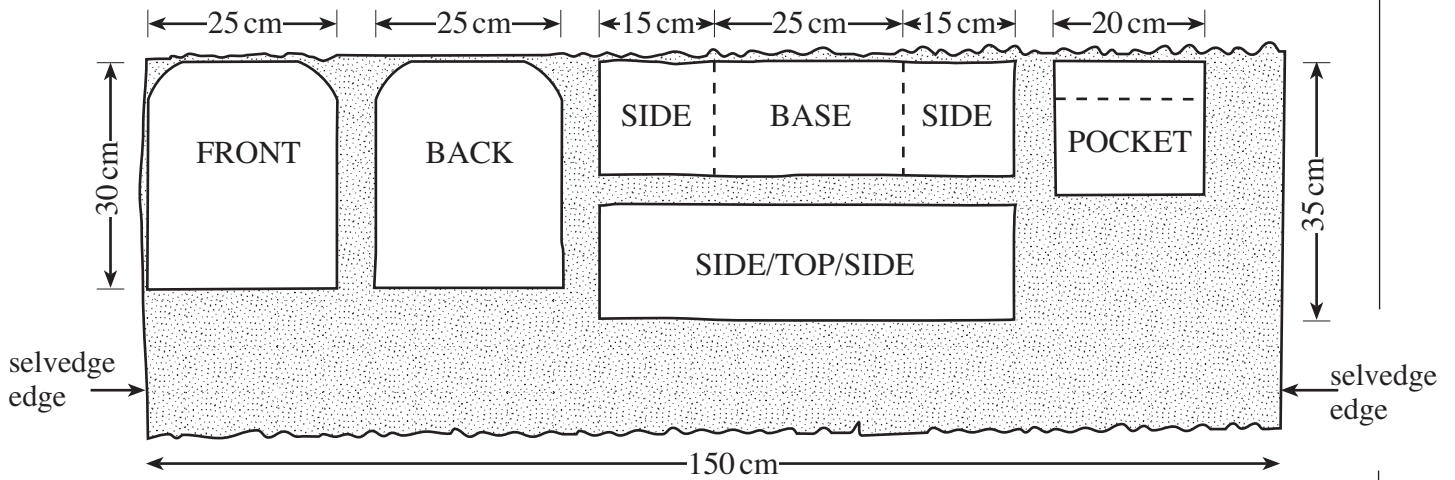

**State** the minimum length of material needed to make the rucksack. [2]

.....

(iii) *Cordura* material costs £10 per metre length. **State** how much it would cost for the amount you stated in part (ii). **Show** your calculation. [2]

.....

.....

(d) The star profile diagram below shows the strengths and weaknesses of the rucksack.

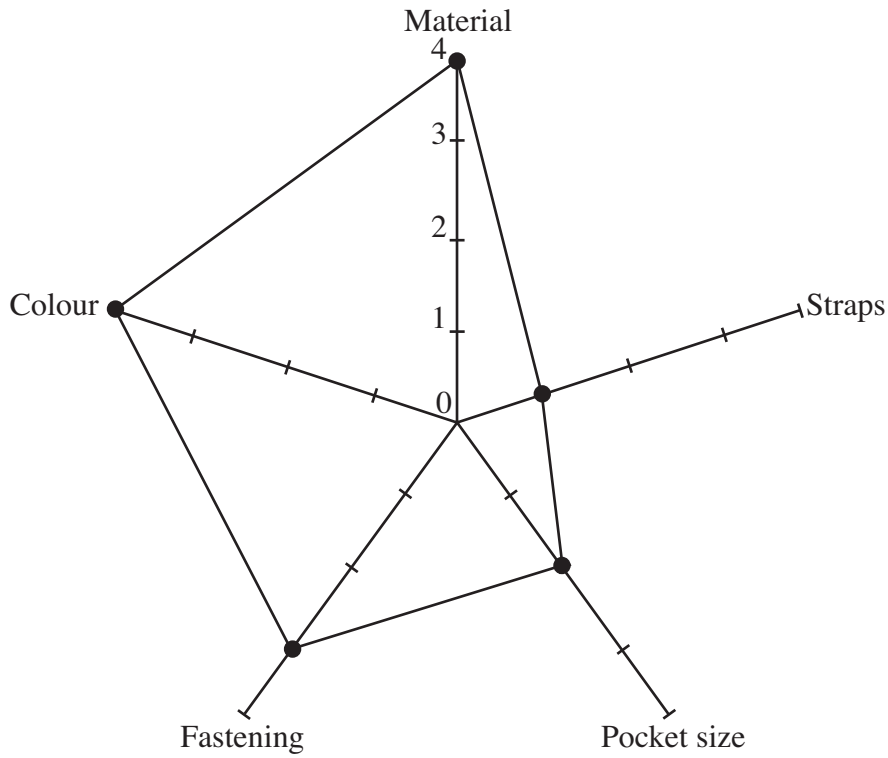

**KEY**

- 1 – Very poor
- 2 – Poor
- 3 – Good
- 4 – Excellent

(i) **Name two** of the best features of the rucksack. [2]

.....  
 .....

(ii) **Name one poor** feature of the rucksack and in the space below, use notes and sketches to **show** how this feature can be improved.

Poor feature: ..... [1]

Method of improvement: ..... [5]

**BLANK PAGE**

3. Designers use nature as a source of inspiration for new ideas. The photograph below shows a collection of items found on a beach.



- (a) Use the collection of items shown above as inspiration to produce a design which can be added to the plain white T-shirt shown below.

**Marks will be awarded for:**

- creating an imaginative and colourful design; [4]
- using the photograph for inspiration; [2]
- labelling the diagram to show how the design could be applied to the T-shirt. [3]

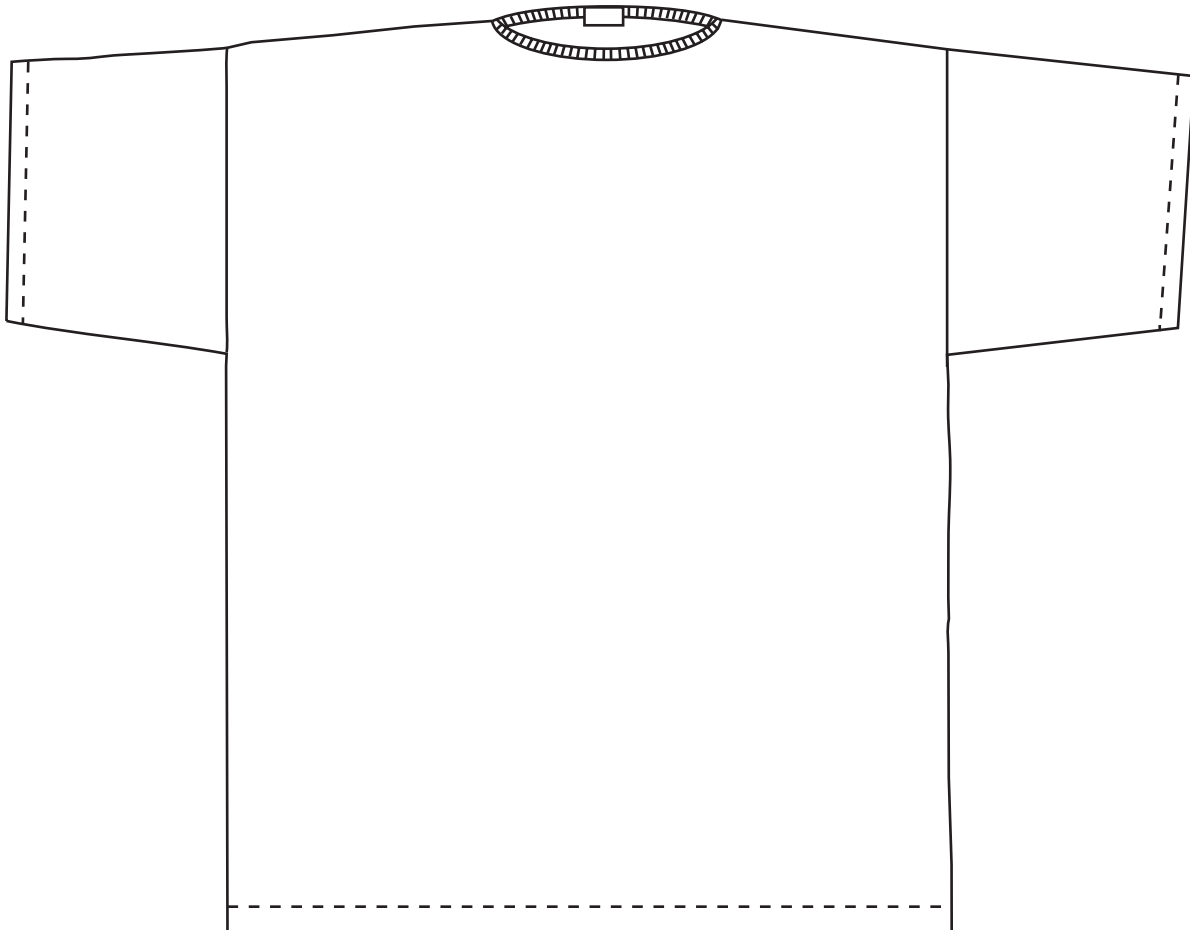



- (b) (i) **Describe two** methods that you could use to present design ideas for a new collection of winter clothing. 2 × [2]

Method 1: .....

.....

Method 2: .....

.....

- (ii) **Choose one** of the methods you have described in (i) and **explain two** advantages of using this method to show your design ideas. 2 × [2]

Method: .....

Advantage 1: .....

.....

Advantage 2: .....

.....

- (c) Supermarkets are now selling a range of clothes and accessories. **Give three** reasons why supermarket ranges of clothing and accessories are popular. [3]

Reason 1: .....

.....

Reason 2: .....

.....

Reason 3: .....

.....

4. People are encouraged to ‘*reduce, reuse and recycle*’. The picture below shows a plastic wash bag made from recycled drinks containers.



- (a) **Give two** reasons why some manufacturers are using recycled materials to make their products. 2 × [2]

Reason 1: .....

.....

Reason 2: .....

.....

- (b) The sketch below shows some of the main style details used on denim jeans.

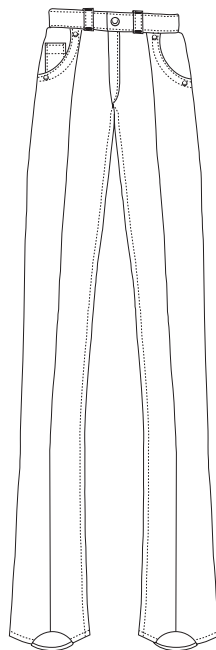

FRONT

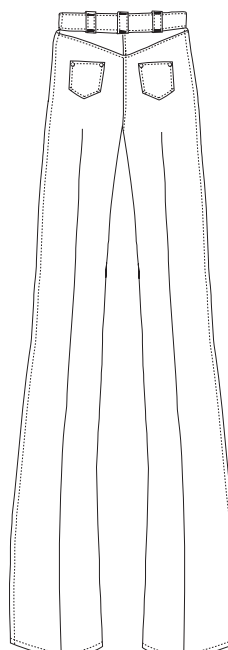

BACK

**Sketch** and **label one interesting** idea to show how an old pair of denim jeans could be used to create a fashion accessory.

**Marks will be awarded for:**

- a clearly labelled design idea; [4]
- using at least **one** feature from the original jeans. [2]

(c) In industry, batches of materials are carefully checked for faults.  
**Give two** quality checks that could be carried out on a length of material before it is used in a textile product. [2]

Check 1: .....

.....

Check 2: .....

.....

- (d) The diagrams below show a pair of shorts and one of the pattern templates that could be used to make them.

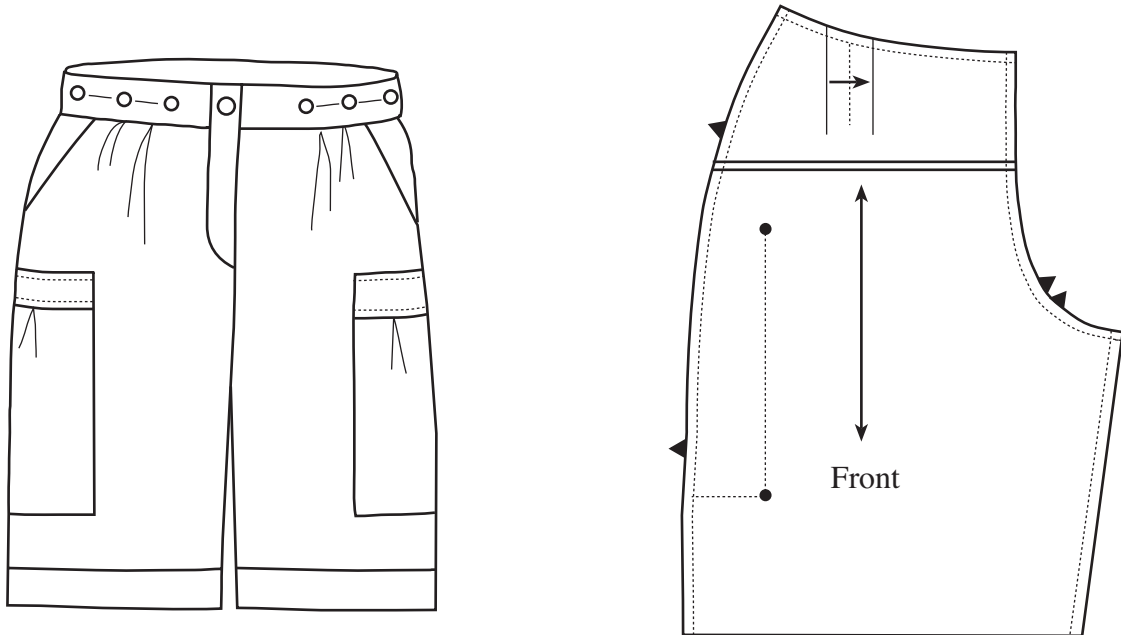

- (i) **Explain** the meaning of **each** of the following symbols shown on the pattern 2 × [2]  
template.

<p>This symbol means</p> <p>.....</p> <p>.....</p> <p>.....</p> <p>.....</p> <p>.....</p>	<p>This symbol means</p> <p>.....</p> <p>.....</p> <p>.....</p> <p>.....</p> <p>.....</p>

(ii) The diagrams below show a view of the shorts folded inside out and a close up view of the seam detail.

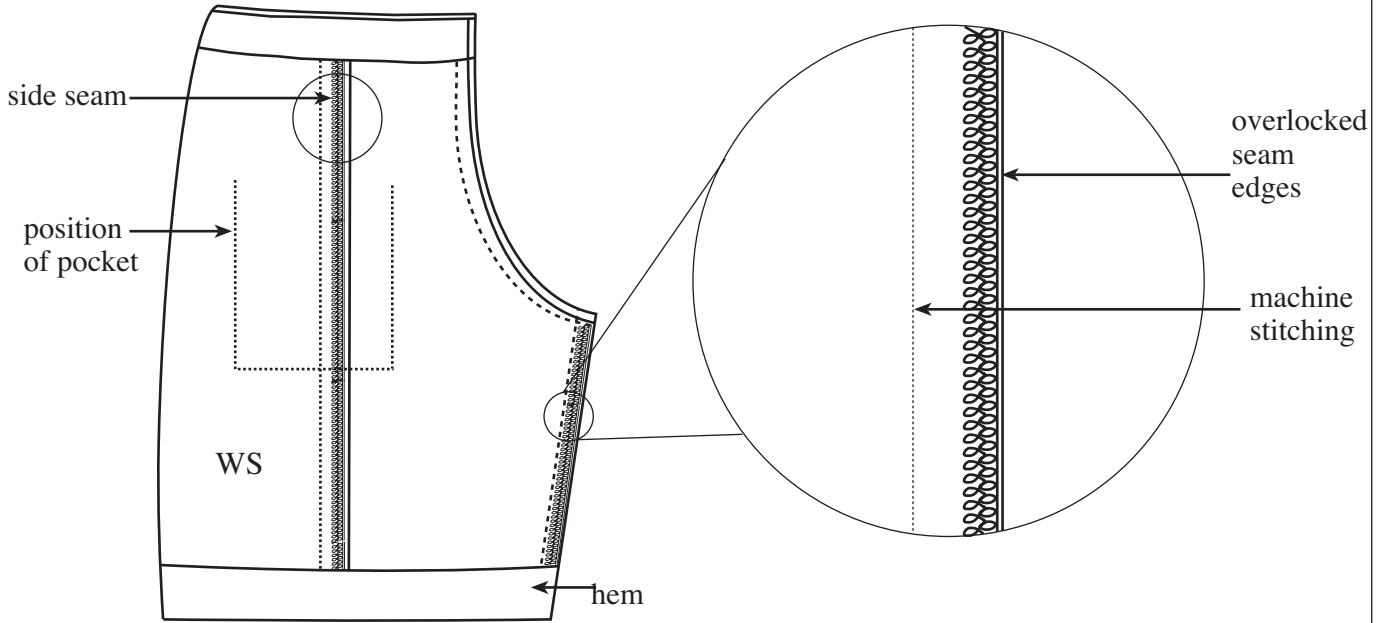

(I) **Give one** advantage of using an *overlocker* to neaten the seams. [2]

.....

.....

(II) In the space below, **sketch** and **label** a *different* method that could be used to neaten the seams. [3]

5. Popular films, stories and cartoon characters are often used as a theme for decorating and furnishing children’s rooms.

(a) Using a theme of your own choice, **sketch** and **label one** idea, on the page opposite, for an imaginative and innovative floor cushion for use in a child’s room.

**Your design must:**

- reflect a popular film, story or cartoon character that would appeal to a child;
- show clear details of the design and construction of the cushion, including an opening so that the outer covering can be removed for washing;
- make use of a range of warm colours.

**Marks will be awarded for:**

- (i) a detailed design which reflects the theme and shows the front and back views; [5]
- (ii) using a warm colour scheme; [3]
- (iii) construction details for an opening; [5]
- (iv) two important dimensions; [2]
- (v) quality of communication. [5]

(b) **Name** the main material that you would choose to use for the outer cover and **give two** reasons for your choice. [5]

Name of material: .....

Reason 1: .....

.....

.....

Reason 2: .....

.....

.....

Theme: .....

**For continuation only.**

A series of horizontal dotted lines for writing.