

Thursday 21 June 2012 – Afternoon

GCSE DESIGN AND TECHNOLOGY Textiles Technology

A574 Technical Aspects of Designing and Making

Candidates answer on the Question Paper.

OCR supplied materials:

None

Other materials required:

None

Duration: 1 hour 15 minutes



Candidate forename		Candidate surname	
--------------------	--	-------------------	--

Centre number						Candidate number				
---------------	--	--	--	--	--	------------------	--	--	--	--

INSTRUCTIONS TO CANDIDATES

- Write your name, centre number and candidate number in the boxes above. Please write clearly and in capital letters.
- Use black ink. HB pencil may be used for graphs and diagrams only.
- Read each question carefully. Make sure you know what you have to do before starting your answer.
- Write your answer to each question in the space provided. If additional space is required, you should use the lined page at the end of this booklet. The question number(s) must be clearly shown.
- Answer **all** the questions in Section A **and** Section B.
- Do **not** write in the bar codes.

INFORMATION FOR CANDIDATES

- The number of marks is given in brackets [] at the end of each question or part question.
- The total number of marks for this paper is **60**.
- Your quality of written communication is assessed in the questions marked with an asterisk (*).
- This document consists of **12** pages. Any blank pages are indicated.

Section A

Answer **all** questions.

1 Fig. 1 shows a basic sewing machine.

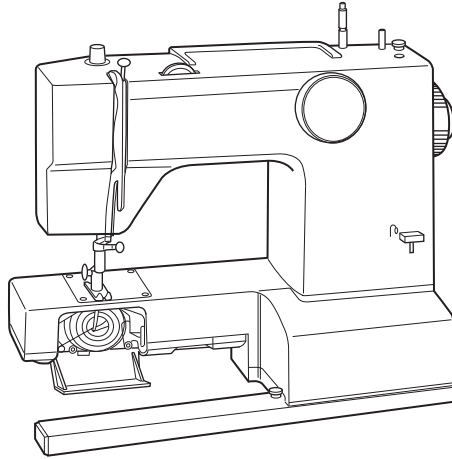



Fig. 1

(a) List **four** checks that should be carried out before using a sewing machine.

- 1
- 2
- 3
- 4 [4]

(b) Fabrics can be permanently joined using a sewing machine stitch.

Complete the table below by naming the **two** stitches shown.

Machine Stitch	Name



[2]

(c) Free machine embroidery is a decorative technique worked using a sewing machine.

Complete the table below to describe how to work free machine embroidery.

Stage	Method
Preparation of fabric	
Preparation of machine	
Finishing	

[6]

[Total: 12]

(c) Fig. 3 shows the seam used to make the shirt.

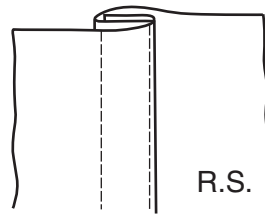

Fig. 3

Name the seam shown in Fig. 3.

..... [1]

(d) The shirt is fastened using buttons and buttonholes.

Describe, using notes and/or diagrams, how to work the buttonholes.

[6]

[Total: 12]

Turn over

3 (a) Complete the chart below by naming the methods of disposal of fullness shown.

Give an example of where each method could be used.

The first one has been done for you.

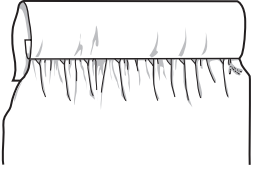
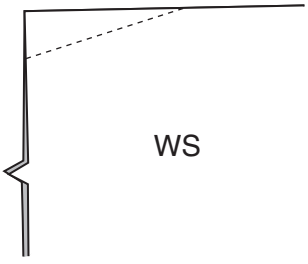
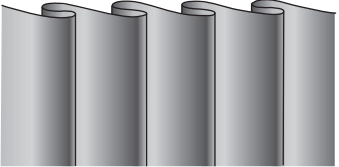
Disposal of fullness	Name of Method	Use
	<p>gathers</p>	<p>At the bottom of a sleeve where it goes into the cuff</p>
		
		

[4]

(b) Pattern markings for disposal of fullness need to be transferred from the pattern pieces to the fabric.

State **two** methods used in the textile industry to transfer pattern markings from the pattern pieces to the fabric.

1

2 [2]

Section B

Answer **all** questions.

4 Fig. 5 shows a pair of sunglasses.

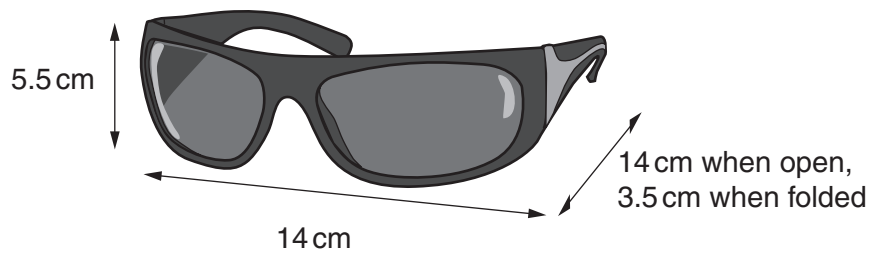

Fig. 5

The manufacturer requires a fabric case for the sunglasses to be made.

The case should:

- protect the sunglasses
- be easy to carry
- be inexpensive to manufacture.

(a) In the space below sketch a design for the sunglasses case.

Annotate your sketch to show design and construction details and how it meets the specification.

(b) In the space below, draw the pattern pieces needed to make the sunglasses case you designed in part (a).

[4]

(c) Give **two** reasons for using pattern pieces when manufacturing textiles products.



1

2 [2]

[Total: 12]

5 (a) Complete the chart below.

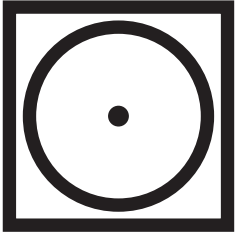
Name the symbols shown, state what they mean and suggest a product they could be found on.

Symbol	Name or meaning	Product found on
		
		
		

[6]

