

Candidate Name	Centre Number	Candidate Number



OXFORD CAMBRIDGE AND RSA EXAMINATIONS
General Certificate of Secondary Education

DESIGN & TECHNOLOGY:
INDUSTRIAL TECHNOLOGY

1959/3

PAPER 3 Foundation Tier

Thursday **16 JUNE 2005** Afternoon 1 hour

Candidates answer on the question paper.
 No additional materials are required.

TIME 1 hour

INSTRUCTIONS TO CANDIDATES

Write your name, Centre number and candidate number in the spaces at the top of this page.

Answer **all** questions.

Write your answers in the spaces provided on the question paper.

INFORMATION FOR CANDIDATES

The number of marks is given in brackets [] at the end of each question or part question.

All dimensions are in millimetres.

Assume any mechanical system to be 100% efficient.

FOR EXAMINER'S USE	
1	
2	
3	
4	
5	
TOTAL	

This question paper consists of 12 printed pages.

- 1 Fig. 1 shows a view of a litter picker. It is made from a number of different materials.

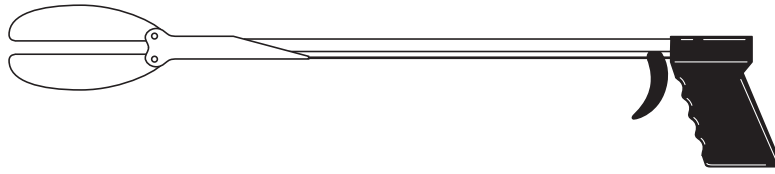



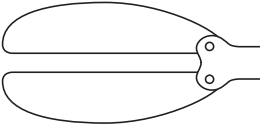

Fig. 1

- (a) Complete the table choosing a suitable material for each part from the list below.

acrylic
aluminium
steel
lead
ABS
rubber

drawing of part	name of part	name of material
	trigger	
	handle	
	frame	
	jaws	

[4]

(b) The litter picker shown below is joined together with a number of fixing devices.

Complete the table below by naming the fixing device and circling the letter where it would be used on the litter picker.

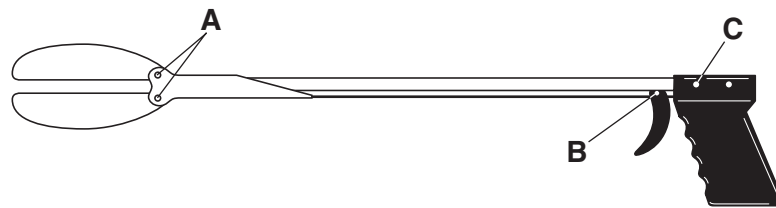

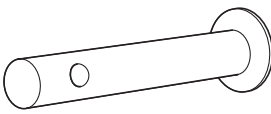
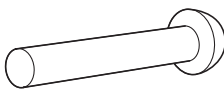
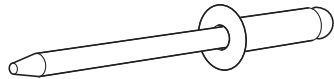
drawing of part	fixing device	place where used
		A B C
		A B C
		A B C

[6]

- 2 Fig. 2 shows the jaws of the litter picker.

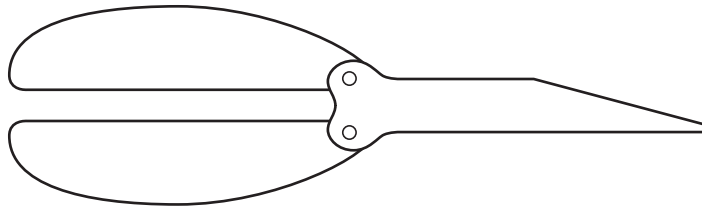

Fig. 2

- (a) The jaws of the litter picker do not grip.

Using notes and sketches show how to improve the jaws.

[2]

Fig. 3 shows the trigger of the litter picker.



Fig. 3

The outer shape of the trigger has been made with the use of a template.

- (b) Explain how a template will help to make the trigger shape.

[2]

Fig. 4 shows the trigger of the litter picker with a hole drilled at one end.



Fig. 4

A batch of 50 is to be produced.

(c) (i) Give **two** reasons for using a jig to help drilling the triggers.

Reason 1 _____ [1]

Reason 2 _____ [1]

(ii) Using notes and sketches, show a possible design for the jig.

The jig must:

- locate the work easily;
- hold the work securely;
- position the hole accurately;
- be held in a machine vice.

[4]

- 3 Fig. 5 shows views of a P.V.C blister package used to hold and display heavy-duty padlocks.



Fig. 5

The blister pack is manufactured using the vacuum forming process.

- (a) Complete the chart below to show how the blister pack can be made using the vacuum forming process.

Step 1	Make the mould from which the blister pack will be made.
Step 2	
Step 3	
Step 4	
Step 5	
Step 6	

[5]

- (b) The blister pack must be tested to make sure that it can hold the padlock and will not split or crack.

Use notes and sketches to show how you would test the pack.

[3]

- (c) When tested the blister pack splits and cracks.

Describe **two** design changes that can be made to improve the durability of the pack.

1 _____

2 _____

[2]

- 4 Fig. 6 shows a design for a new mobile telephone.

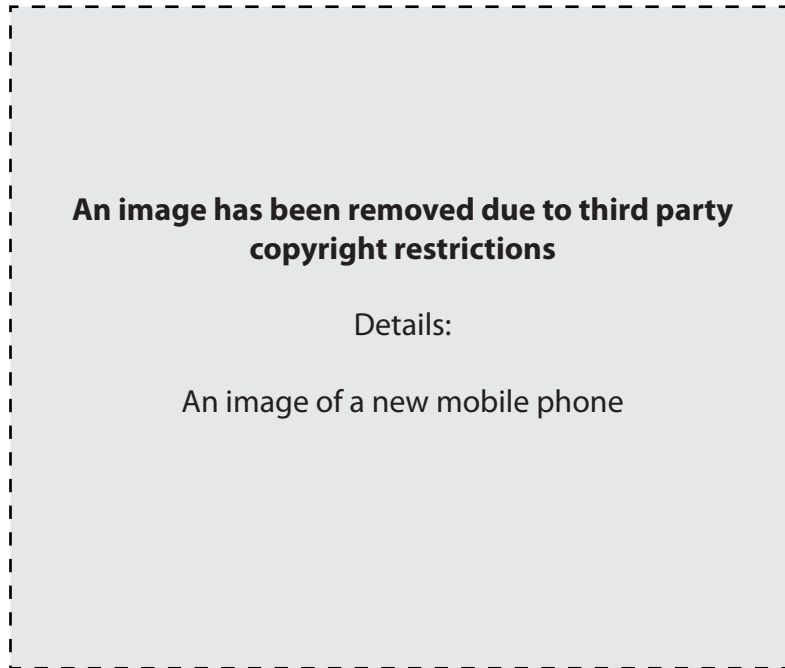

Fig. 6

- (a) The mobile telephone has been designed using a CAD package.

Complete the table by describing each CAD menu term.

Grab/Select	
Group/Ungroup	
Drag/Move	
Copy/Paste	

[8]

- (b) State **two** ways in which computer generated designs can be stored electronically.

1 _____ [1]

2 _____ [1]

- 5 Fig. 7 shows two views of a pocket plastic comb and mirror set. It is the size of a credit card and 5mm thick.

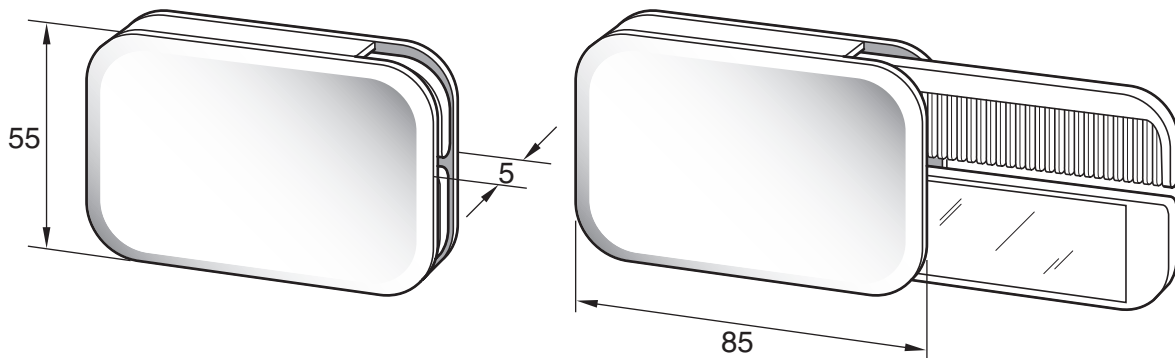

Fig. 7

- (a) Name a suitable thermoplastic and manufacturing process for the production of the comb.

Thermoplastic _____ [1]

Manufacturing Process _____ [1]

It has been found that the comb and mirror fall out of the case easily when it is in a pocket or handbag.

- (b) Using notes and sketches, show a design modification that will help keep the comb and mirror inside until needed.

The overall size of the case should not change.

[3]

The manufacturers have decided to design and manufacture a credit card sized tool set.

(c) Use notes and sketches to show a design for the set with the following specification points:

- credit card sized case 5mm thick;
- to include a screwdriver, tape measure, small file;
- all tools are held securely until needed.

[5]

Permission to reproduce items where third-party owned material protected by copyright is included has been sought and cleared where possible. Every reasonable effort has been made by the publisher (OCR) to trace copyright holders, but if any items requiring clearance have unwittingly been included, the publisher will be pleased to make amends at the earliest possible opportunity.

OCR is part of the Cambridge Assessment Group. Cambridge Assessment is the brand name of University of Cambridge Local Examinations Syndicate (UCLES), which is itself a department of the University of Cambridge.