

Friday 25 January 2013 – Morning

GCSE DESIGN AND TECHNOLOGY Graphics

A534/01 Technical Aspects of Designing and Making

Candidates answer on the Question Paper.

OCR supplied materials:

None

Other materials required:

None

Duration: 1 hour 15 minutes

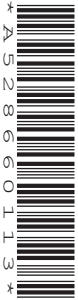

Candidate forename		Candidate surname	
--------------------	--	-------------------	--

Centre number						Candidate number				
---------------	--	--	--	--	--	------------------	--	--	--	--

INSTRUCTIONS TO CANDIDATES

- Write your name, centre number and candidate number in the boxes above. Please write clearly and in capital letters.
- Use black ink. HB pencil may be used for graphs and diagrams only.
- Read each question carefully. Make sure you know what you have to do before starting your answer.
- Write your answer to each question in the space provided. Additional paper may be used if necessary but you must clearly show your candidate number, centre number and question number(s).
- Answer **all** the questions **in Section A and Section B**.
- Do **not** write in the bar codes.

INFORMATION FOR CANDIDATES

- The number of marks is given in brackets [] at the end of each question or part question.
- The total number of marks for this paper is **60**.
- Your Quality of Written Communication will be assessed in questions marked with an asterisk (*).
- This document consists of **12** pages. Any blank pages are indicated.

SECTION A

Answer **all** questions.

1 Fig. 1 shows a card box for a tube of glue.

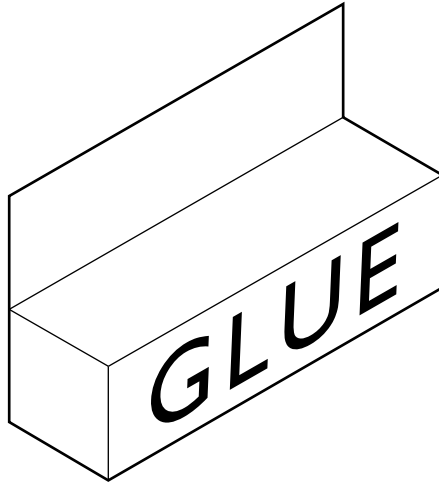

Fig. 1

(a) State **one** reason why the tube of glue is packaged in the card box.

..... [1]

(b) Complete the two-point perspective sketch of the card box below.

V.P.
X

V.P.
X

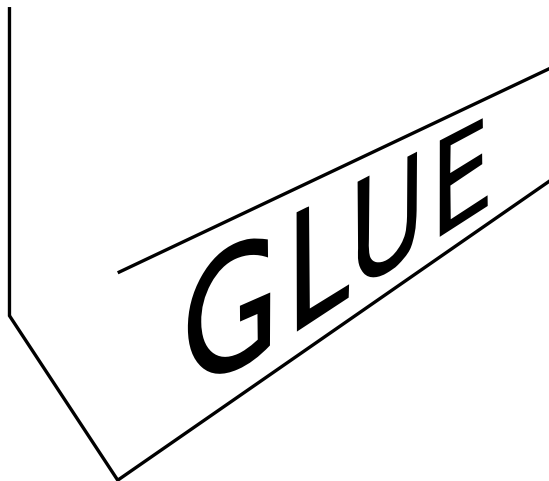

[3]

(c) The safety symbols shown below are to be printed onto the card box in Fig. 1. State the meaning of each symbol.

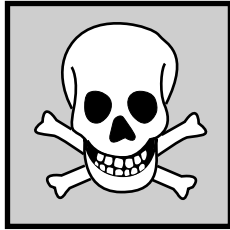

(i)

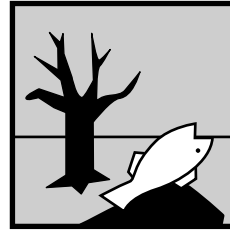

(ii)

[2]

(d) Give **two** safety precautions that must be followed when using solvent based glue.

1

2

[2]

(e) Images are to be printed on the card box to show the different materials that can be joined using the glue.

Add appropriate texture to the two blocks below to make them appear more realistic.

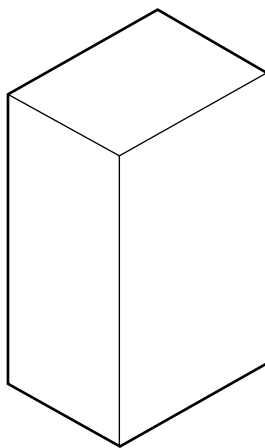

Wood

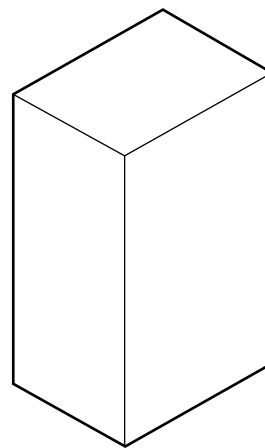

Glass

[4]

[Total: 12]

2 Fig. 2 shows a package for a disposable camera. The package is made from thin card.

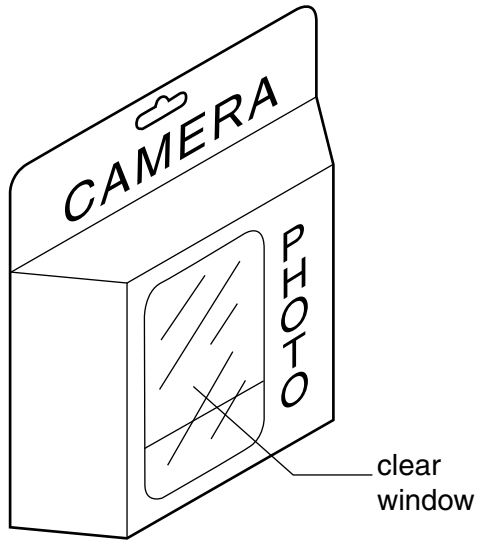

Fig. 2

(a) Complete the orthographic view of the package below.

Top

Side

Front

- (b) To allow the camera to be viewed, the window in the package is made from clear PVC sheet. State **one** other reason why this is a suitable material for the window.

.....
..... [1]

- (c) In the space below, use notes and sketches to show how the PVC sheet for the window would be cut out and fixed to the package.

[2]

- 3 Fig. 3 shows a development (net) of a children’s meal box. The box is made from one sheet of thin card.

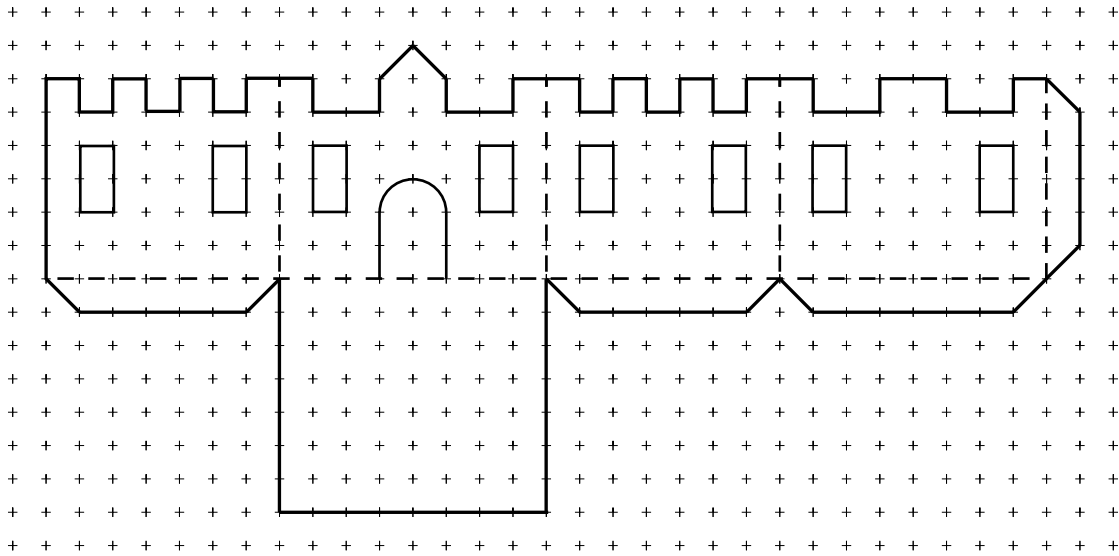
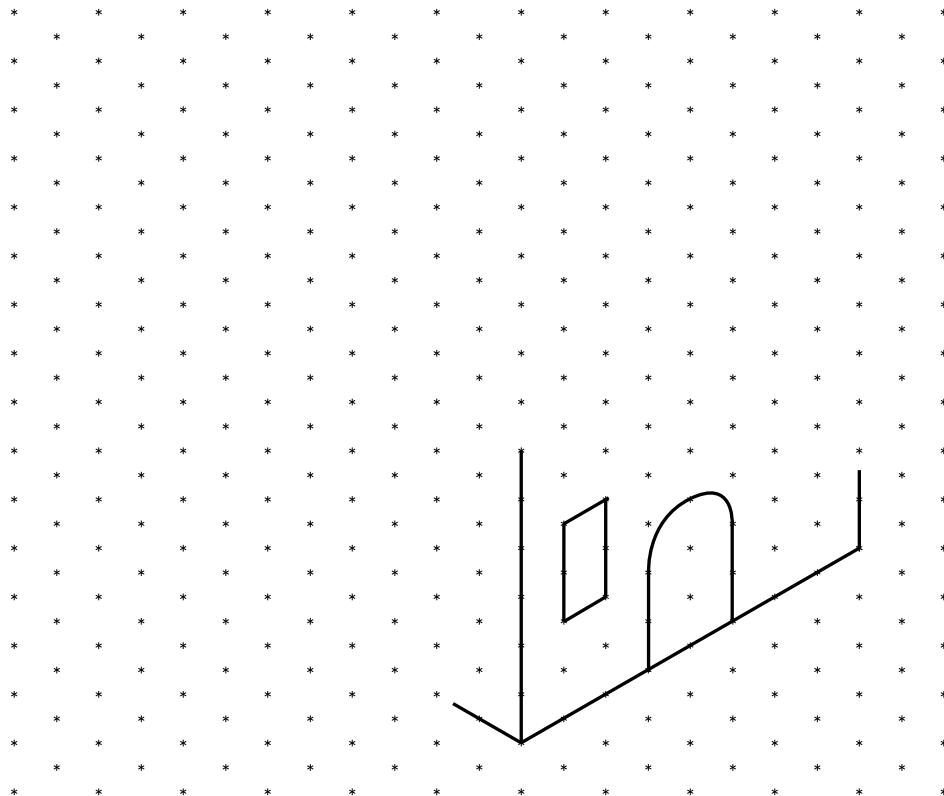

Fig. 3

- (a) Complete the isometric view of the assembled meal box below.



[4]

- (b) The boxes are to be made in a batch of 5000.
Name an appropriate method of cutting out the developments (nets).

..... [1]

(c) Fig. 4 shows some laminated card figures given away with the meal.



Fig. 4

Give **two** reasons for laminating the card figures.

1

2

[2]

(d) Describe the process of laminating card.

.....

.....

..... [2]

(e) (i) Using sketches and notes, design a Styrofoam stand to make the cards stand up vertically. The stand only needs to hold one card.

[2]

(ii) Name **one** tool that could be used to shape the Styrofoam stand.

..... [1]

[Total: 12]

SECTION B

Answer **all** questions.

4 Fig. 5 shows a pizza box made from corrugated card.

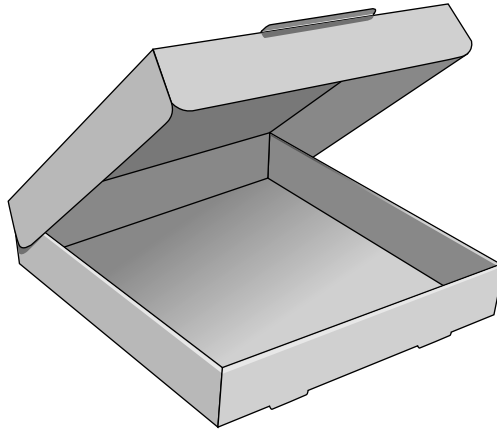
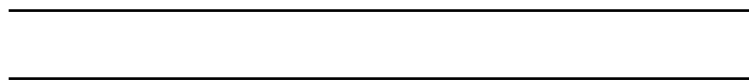

Fig. 5

(a) State **one** reason why corrugated card is a suitable material for pizza boxes.

..... [1]

(b) Complete the sectional view of corrugated card below.



[1]

(c) Give **two** reasons why the pizza boxes are sent to the pizza shop 'flat packed'.

1

2

[2]

(d) Fig. 6 shows two logo designs for the pizza box.

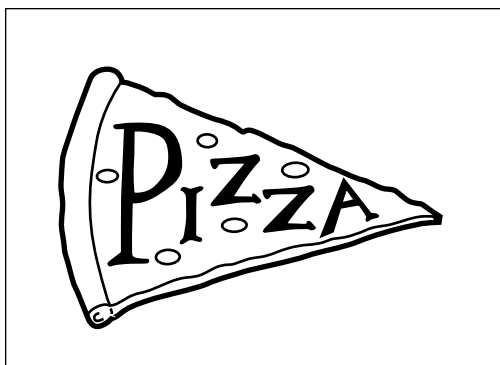

A

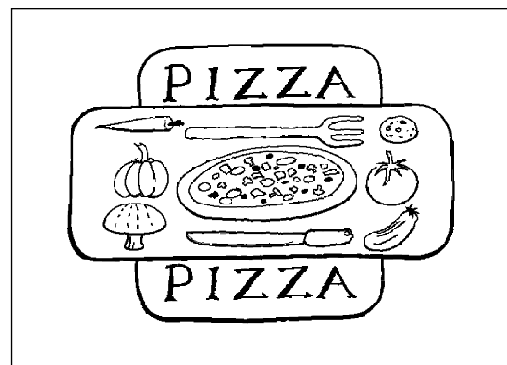

B

Fig. 6

Give **two** reasons why **A** is a more suitable design than **B**.

1

2

[2]

5 Fig. 7 shows a car that is for sale.

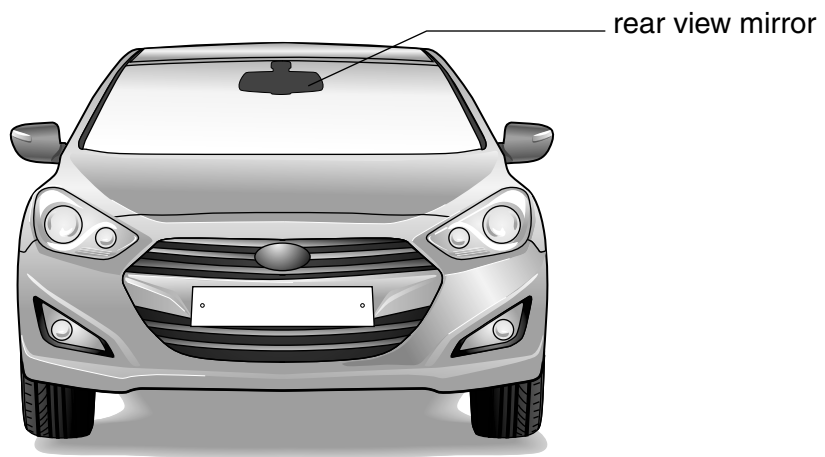

Fig. 7

(a) Using sketches and notes, design a 'For Sale' sign to be displayed inside the car.
The sign must:

- be made from a suitable graphic material
- display a £ sign and four numbers
- include a way of changing the numbers on the sign quickly and easily
- hang from the rear view mirror of the car.

(b) Fig. 8 shows a sign displayed in front of the car. The sign will be left outside in all weather.

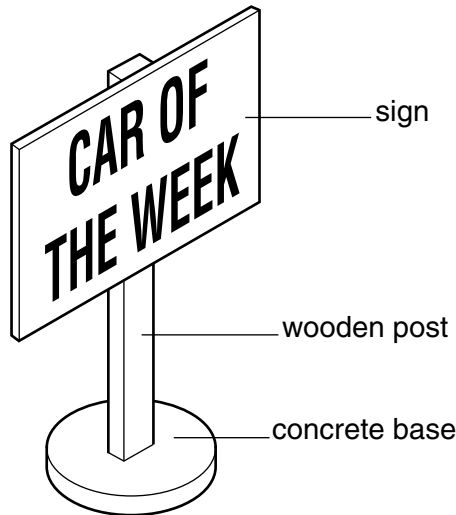

Fig. 8

(i) State **one** property that would make a material suitable for the sign.

..... [1]

(ii) Name **one** suitable graphic material for the sign.

..... [1]

(c) The lettering on the sign is to be made from self-adhesive vinyl. Describe how CAD/CAM could be used to produce the lettering.

.....
.....
.....
.....
.....
..... [3]

(d) State what is meant by the term 'self-adhesive'.

..... [1]

[Total: 12]

Copyright Information

OCR is committed to seeking permission to reproduce all third-party content that it uses in its assessment materials. OCR has attempted to identify and contact all copyright holders whose work is used in this paper. To avoid the issue of disclosure of answer-related information to candidates, all copyright acknowledgements are reproduced in the OCR Copyright Acknowledgements Booklet. This is produced for each series of examinations and is freely available to download from our public website (www.ocr.org.uk) after the live examination series. If OCR has unwittingly failed to correctly acknowledge or clear any third-party content in this assessment material, OCR will be happy to correct its mistake at the earliest possible opportunity.

For queries or further information please contact the Copyright Team, First Floor, 9 Hills Road, Cambridge CB2 1GE.

OCR is part of the Cambridge Assessment Group; Cambridge Assessment is the brand name of University of Cambridge Local Examinations Syndicate (UCLES), which is itself a department of the University of Cambridge.