

<b>Candidate Forename</b>		<b>Candidate Surname</b>	
-------------------------------	--	------------------------------	--

<b>Centre Number</b>						<b>Candidate Number</b>				
--------------------------	--	--	--	--	--	-----------------------------	--	--	--	--

**OXFORD CAMBRIDGE AND RSA EXAMINATIONS  
GENERAL CERTIFICATE OF SECONDARY EDUCATION**

**A532**

**DESIGN AND TECHNOLOGY**

**Sustainable Design**

**FRIDAY 22 JANUARY 2010: Afternoon**

**DURATION: 1 hour**

**SUITABLE FOR VISUALLY IMPAIRED CANDIDATES**

**Candidates answer on the Question Paper**

**OCR SUPPLIED MATERIALS:**

**None**

**OTHER MATERIALS REQUIRED:**

**None**

**READ INSTRUCTIONS OVERLEAF**

## **INSTRUCTIONS TO CANDIDATES**

- **Write your name clearly in capital letters, your Centre Number and Candidate Number in the boxes on the first page.**
- **Use black ink. Pencil may be used for graphs and diagrams only.**
- **Read each question carefully and make sure that you know what you have to do before starting your answer.**
- **Answer ALL the questions in sections A AND B.**
- **Write your answer to each question in the space provided.**

## **INFORMATION FOR CANDIDATES**

- **The number of marks is given in brackets [ ] at the end of each question or part question.**
- **The total number of marks for this paper is 60.**
- **Your Quality of Written Communication is assessed in questions marked with an asterisk (\*).**

## **SECTION A**

**Answer ALL questions.**

**You are advised to spend 15 minutes on this section.**

**On questions 1–5 ring your answer**

- 1 Instructions are included with products to:**
- (a) Promote the company**
  - (b) Provide reading material**
  - (c) Protect the safety of users**
  - (d) Increase sales** **[1]**
- 2 To disassemble a product means to:**
- (a) Take it apart**
  - (b) Make it**
  - (c) Sketch it**
  - (d) Buy it** **[1]**

- 3 A product cannot be economically repaired if:**
- (a) There is no proof of purchase**
  - (b) It is more than three years old**
  - (c) Spare parts are not available**
  - (d) It was expensive to buy** [1]

- 4 The symbol shown stands for:**

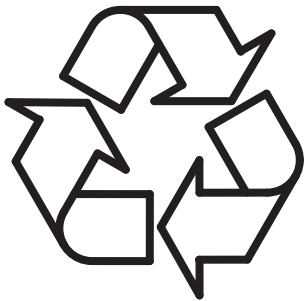

- (a) The product can be recycled**
- (b) The product has been imported**
- (c) Return the product to the shop**
- (d) A recycled product** [1]

- 5 Designers should:**

- (a) Only design for one culture**
- (b) Respond to the values of different cultures**
- (c) Not allow different cultures to affect their thinking**
- (d) Design for their own use** [1]

**6 Which of the 6Rs describes when a product is adapted to suit an alternative purpose?**  
\_\_\_\_\_ [1]

**7 State what is meant by the ‘life cycle of a product’.**  
\_\_\_\_\_ [1]

**8 Give the full name of the abbreviation ETI which relates to company moral issues.**  
\_\_\_\_\_ [1]

**9 State the term used to describe the total effect of the greenhouse gas emissions resulting from a company’s transportation of materials and products.**  
\_\_\_\_\_ [1]

**10 Name the term used to describe waste materials that decompose easily without causing harm to the environment.**  
\_\_\_\_\_ [1]

Decide whether each of the following statements is **TRUE** or **FALSE**.

Tick (✓) the box to show your answer.

**TRUE**   **FALSE**

- |           |  |                          |                          |            |
|-----------|--|--------------------------|--------------------------|------------|
| <b>11</b> | <b>The creation of worldwide production markets with greater access to foreign products is called Globalisation.</b> | <input type="checkbox"/> | <input type="checkbox"/> | <b>[1]</b> |
| <b>12</b> | <b>Careful marking out can reduce waste material.</b>  | <input type="checkbox"/> | <input type="checkbox"/> | <b>[1]</b> |
| <b>13</b> | <b>A questionnaire is used to gather customers' views.</b>   | <input type="checkbox"/> | <input type="checkbox"/> | <b>[1]</b> |
| <b>14</b> | <b>Recycling started during the 20th Century.</b>  | <input type="checkbox"/> | <input type="checkbox"/> | <b>[1]</b> |
| <b>15</b> | <b>An obsolete product cannot be used.</b>   | <input type="checkbox"/> | <input type="checkbox"/> | <b>[1]</b> |

**Total [15]**

## SECTION B

Answer ALL questions

You are advised to spend 45 minutes on this section.

16 Fig. 1 shows a wall calendar.

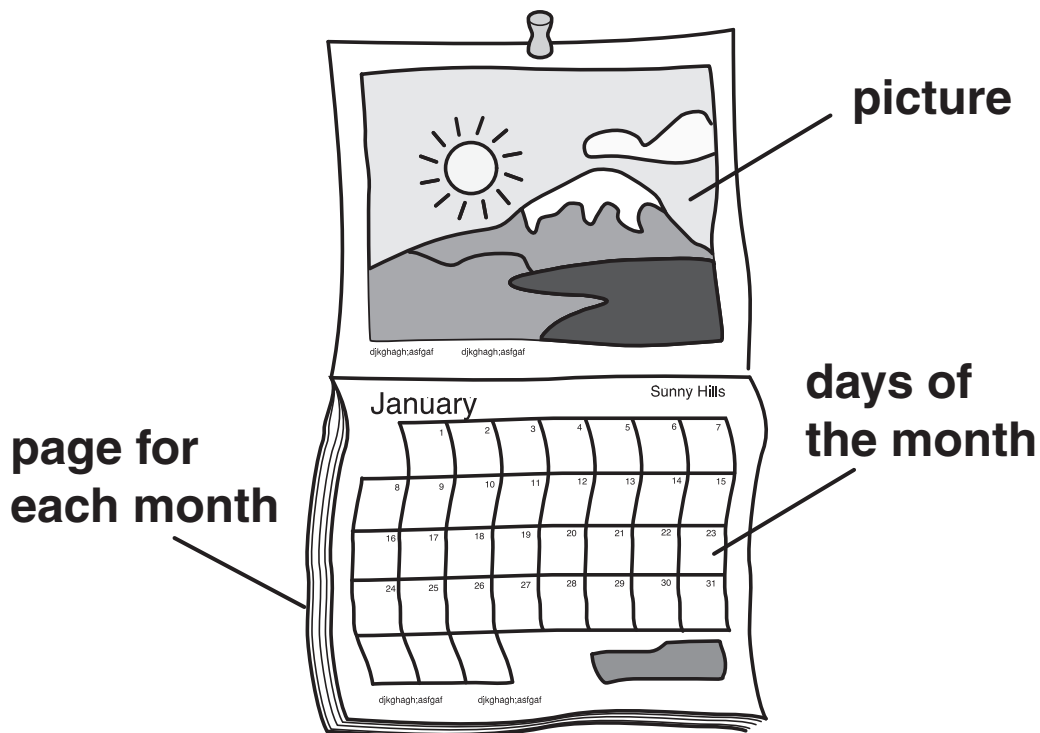

**Fig. 1**

(a) Give ONE reason why the designer would use different pictures for each month on the calendar.

\_\_\_\_\_ [1]

(b) Give ONE example of re-using a picture from the calendar.

\_\_\_\_\_ [1]





**(iii) Carbon offsetting**

---

---

---

---

---

---

---

---

**[3]**

**(d) Describe TWO potential chemical risks to the environment that could be caused during the production of the calendar.**

**Risk 1** \_\_\_\_\_

---

---

**[2]**

**Risk 2** \_\_\_\_\_

---

---

**[2]**

**Total [15]**

17 The calendar in Fig. 2 is printed on paper with wildflower seeds embedded in it. When a page has been used it is planted directly in the ground and wildflowers grow in its place.

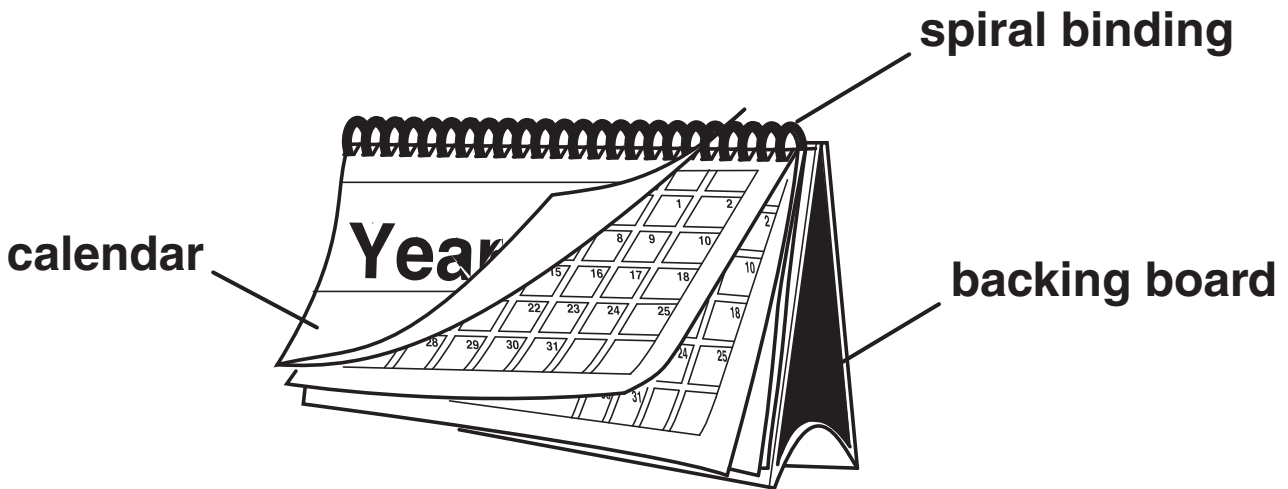

Fig. 2

(a) (i) Name ONE specific material that could be used to make the spiral binding.

\_\_\_\_\_ [1]

(ii) Give TWO advantages for the manufacturer of using a recycled material for the backing board.

1 \_\_\_\_\_

\_\_\_\_\_ [1]

2 \_\_\_\_\_

\_\_\_\_\_ [1]

**(b) Describe how the calendar in Fig. 2 could address the following THREE aspects of the 6Rs.**

**(i) Rethink**

---

---

---

---

---

---

---

---

**[2]**

**(ii) Reduce**

---

---

---

---

---

---

---

---

**[2]**

**(iii) Refuse**

---

---

---

---

---

---

---

---

**[2]**

**(c) A calendar can be both functional and aesthetic.**

**Explain with reference to the calendar in Fig. 2:**

**(i) Functional**

---

---

---

---

---

---

---

---

---

---

**[3]**

**(ii) Aesthetic**

---

---

---

---

---

---

---

---



---

---

**[3]**

**Total [15]**

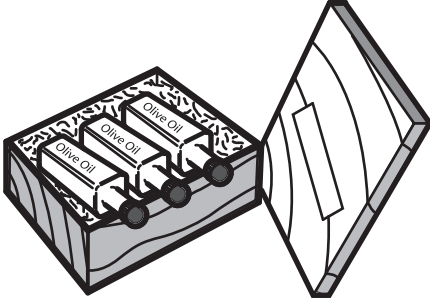
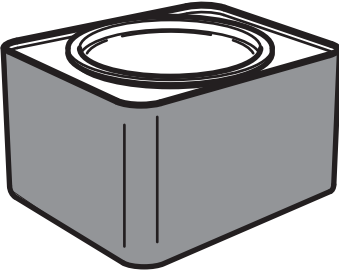
18 (a) (i) Tick (✓) the packaging below that is made from a non-sustainable resource.

 <p>wooden box</p>	 <p>metal tin</p>	 <p>cardboard box</p>
---	--	--

[1]

(ii) Explain what is meant by a non-sustainable resource.

---

---

---

---

---

---

[2]

**(b) Identify the materials used for the box outer and the protective packaging in Fig. 3.**

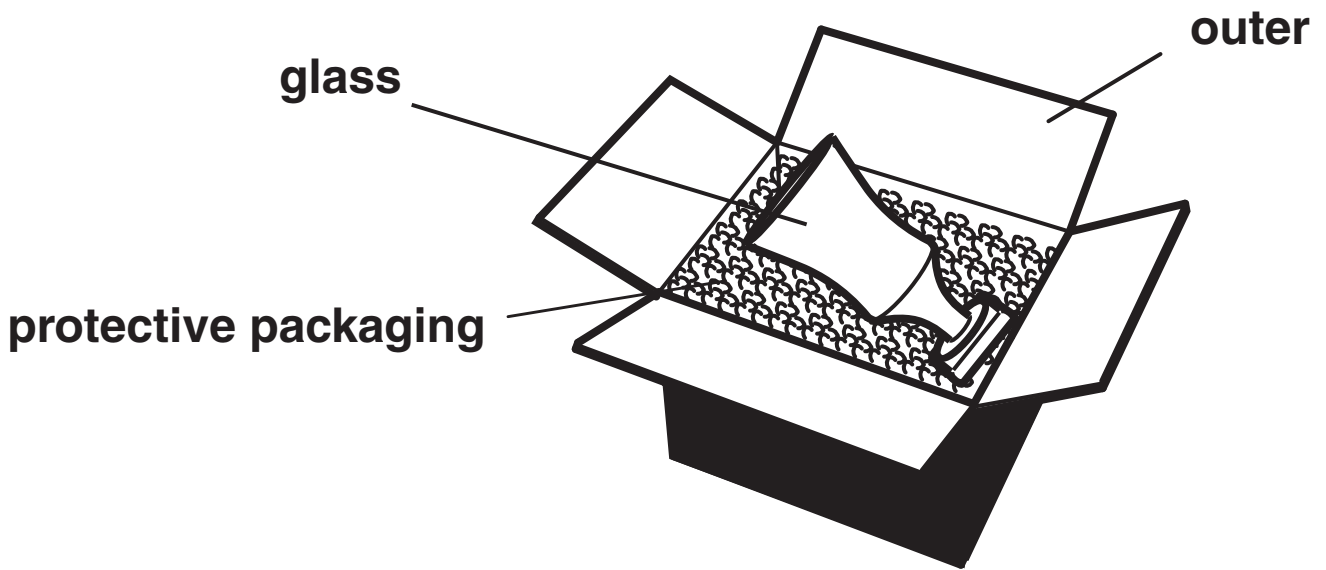

**Fig. 3**

**(i) Outer \_\_\_\_\_ [1]**

**(ii) Protective packaging \_\_\_\_\_ [1]**

**(c) The box in Fig. 3 has been designed to be Eco-friendly.**

**Give ONE point for each of the following headings to show how the box is Eco-friendly.**

**Material** \_\_\_\_\_  
\_\_\_\_\_ [1]

**Manufacture** \_\_\_\_\_  
\_\_\_\_\_ [1]

**Transport** \_\_\_\_\_  
\_\_\_\_\_ [1]

**Disposal** \_\_\_\_\_  
\_\_\_\_\_ [1]

**(d\*) Environmental considerations are important parts of a manufacturing system.**

**Discuss THREE ways in which manufacturing processes can be improved to protect and preserve the environment.**

---

---

---

---

---

---

---

---

---

---

---

---

---

---

---

---

---

---

---

---

---

---

---



---

---

---

---

---

---

[6]

**Total [15]**

**BLANK PAGE**

**BLANK PAGE**



## **Copyright Information**

**OCR is committed to seeking permission to reproduce all third-party content that it uses in its assessment materials. OCR has attempted to identify and contact all copyright holders whose work is used in this paper. To avoid the issue of disclosure of answer-related information to candidates, all copyright acknowledgements are reproduced in the OCR Copyright Acknowledgements Booklet. This is produced for each series of examinations, is given to all schools that receive assessment material and is freely available to download from our public website ([www.ocr.org.uk](http://www.ocr.org.uk)) after the live examination series.**

**If OCR has unwittingly failed to correctly acknowledge or clear any third-party content in this assessment material, OCR will be happy to correct its mistake at the earliest possible opportunity.**

**For queries or further information please contact the Copyright Team, First Floor, 9 Hills Road, Cambridge CB2 1GE.**

**OCR is part of the Cambridge Assessment Group; Cambridge Assessment is the brand name of University of Cambridge Local Examinations Syndicate (UCLES), which is itself a department of the University of Cambridge.**