



**GENERAL CERTIFICATE OF SECONDARY EDUCATION**  
**DESIGN AND TECHNOLOGY**  
**ELECTRONICS AND CONTROL SYSTEMS**  
 Sustainable Design

**A512**

Candidates answer on the Question Paper

**OCR Supplied Materials:**  
None

**Other Materials Required:**  
None

**Tuesday 26 January 2010**  
**Morning**  
 Duration: 1 hour

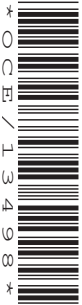

Candidate Forename		Candidate Surname	
--------------------	--	-------------------	--

Centre Number						Candidate Number				
---------------	--	--	--	--	--	------------------	--	--	--	--

**INSTRUCTIONS TO CANDIDATES**

- Write your name clearly in capital letters, your Centre Number and Candidate Number in the boxes above.
- Use black ink. Pencil may be used for graphs and diagrams only.
- Read each question carefully and make sure that you know what you have to do before starting your answer.
- Answer **all** the questions.
- Do **not** write in the bar codes.
- Write your answer to each question in the space provided, however additional paper may be used if necessary.

**INFORMATION FOR CANDIDATES**

- The number of marks is given in brackets [ ] at the end of each question or part question.
- The total number of marks for this paper is **60**.
- Your Quality of Written Communication is assessed in questions marked with an asterisk (\*).
- This document consists of **12** pages. Any blank pages are indicated.

**Section A**

Answer **all** questions.

You are advised to spend 15 minutes on this section.

On questions 1–5 **circle** your answer.

**1** With reference to the 6R statements, which describes 'reduce'?

- A** Product designed to be disassembled.
- B** Parts will be replaced.
- C** Fewer parts will be needed.
- D** Make smaller models.

[1]

**2** Solar power devices are fitted to houses to:

- A** Save water.
- B** Stop draughts.
- C** Make houseplants grow.
- D** Reduce energy costs.

[1]

**3** When buying fairtrade goods you can expect the product to:

- A** Be made by multinational companies.
- B** Be sold at a price which supports the growers and producers.
- C** Be made in a factory with exploited labour.
- D** Be decorated with earth colours.

[1]

4 Carbon dioxide emissions are linked to:

- A Greenhouse gases in the atmosphere.
- B Bubbles in water.
- C Charcoal drawing pencils.
- D Shortage of oil.

[1]

5 The symbol below stands for:

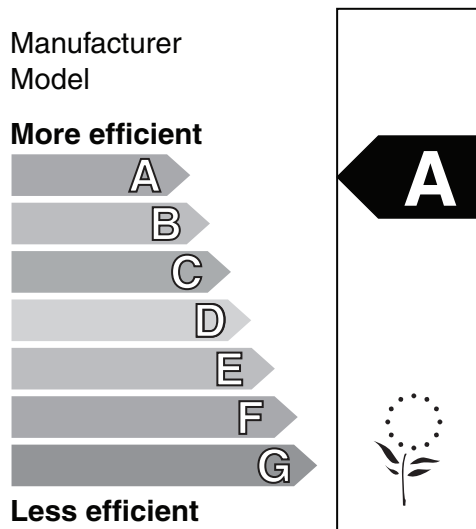

- A Community action.
- B Recyclable material.
- C Un-packing instructions.
- D Energy saving.

[1]

6 Fig. 1 shows a label on an electronic power adaptor.

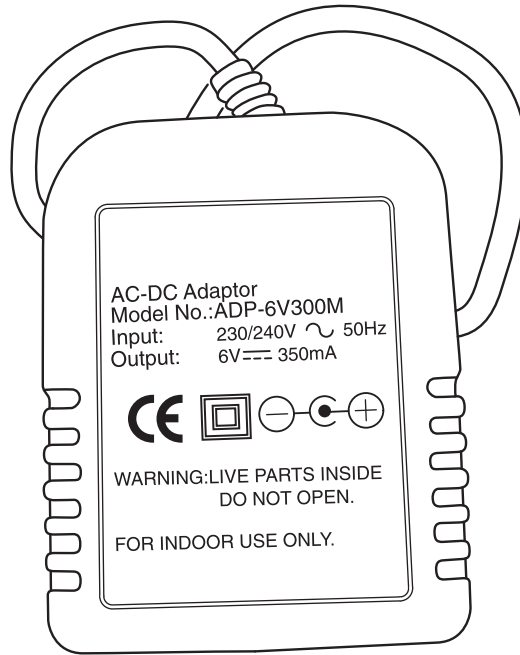

Fig. 1

Give the reason for using a symbol to indicate the power adaptor is double insulated rather than words.

..... [1]

7 What label or letters show that timber is from a managed renewable resource?

..... [1]

8 Which group of plastics is **not** easily recyclable?

..... [1]

9 A lightbulb package is marked 230v 11 w. State why this indicates this is a low energy light bulb.

..... [1]

10 What is the name given to the method of home recycling of vegetables and garden waste?

..... [1]

Decide whether each of the following statements is **true** or **false**.  
Tick (✓) the box to show your answer.

- |   | <b>True</b>              | <b>False</b>             |            |
|---|--------------------------|--------------------------|------------|
| <b>11</b> LEDs are very efficient compared to filament bulbs.                                     | <input type="checkbox"/> | <input type="checkbox"/> | <b>[1]</b> |
| <b>12</b> Gas powered patio heaters are an efficient use of non-renewable energy.                 | <input type="checkbox"/> | <input type="checkbox"/> | <b>[1]</b> |
| <b>13</b> Manufacturing can cause environmental problems.   | <input type="checkbox"/> | <input type="checkbox"/> | <b>[1]</b> |
| <b>14</b> Leaving a television on standby uses no energy.   | <input type="checkbox"/> | <input type="checkbox"/> | <b>[1]</b> |
| <b>15</b> Rechargeable nickel cadmium (nicad) batteries should be disposed of in a landfill site. | <input type="checkbox"/> | <input type="checkbox"/> | <b>[1]</b> |

**Section A Total [15]**

**Section B**

Answer **all** questions.

You are advised to spend 45 minutes on this section.

**16** Renewable energy can power electrical products.

**(a)** Give **two** ways of producing renewable electrical energy.

1 .....  
..... [1]

2 .....  
..... [1]

**(b)** Improvements in technology can lead to new products.

Fig. 2 shows a battery powered sports car.

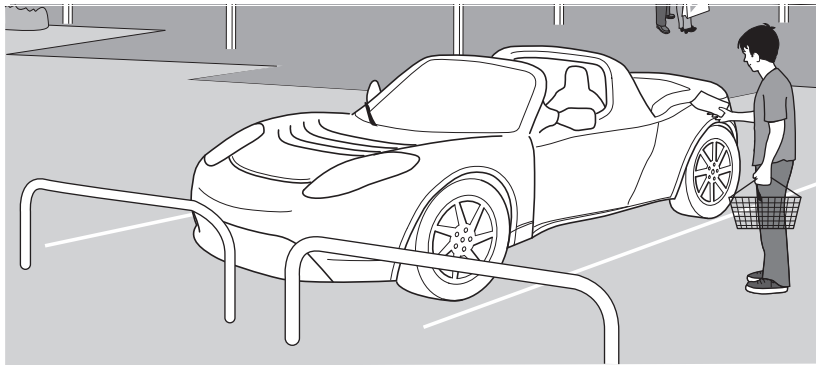

**Fig. 2**

1 State **two** ways new technology is used in the design and manufacture of modern vehicles.  
.....  
.....  
..... [2]

2 State **two** environmental issues with electrically powered cars.  
.....  
.....  
..... [2]

3 Describe how renewable energy can be used to power electric cars.

.....  
.....  
.....  
.....  
..... [4]

(c) When using mirrors to collect energy from the sun the power can be focussed to give very high temperatures.

(i) State **three** ways this energy can be used.

1 .....  
..... [1]

2 .....  
..... [1]

3 .....  
..... [1]

(ii) Give a suitable location for a solar energy farm.

..... [1]

(iii) Give a method of storing collected solar energy for use during the night.

..... [1]

**Total [15]**

17 Fig. 3 shows a wind up torch with the handle out for winding.

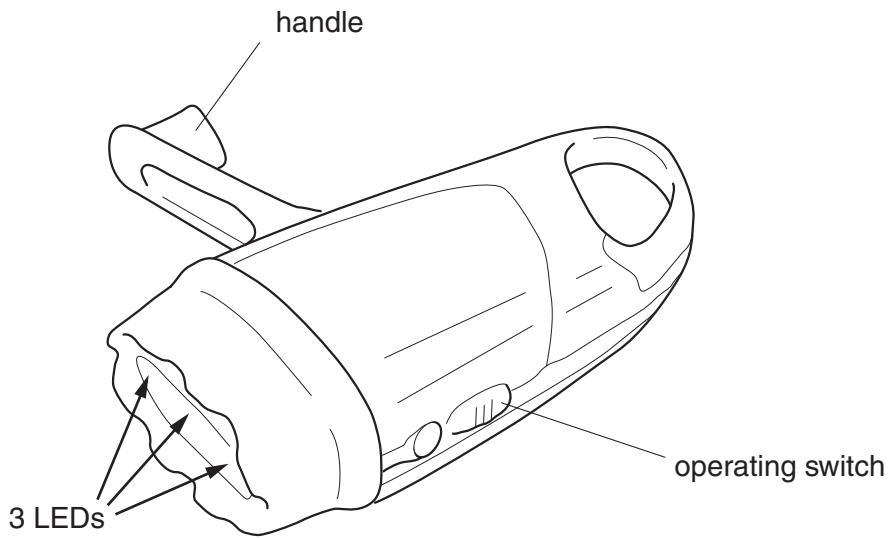

Fig. 3

(a) A specification point is: use a turning handle to provide energy.

List **three** more specification points the designer would have used for the product.

- 1 .....
  - 2 .....
  - 3 .....
- ..... [3]

(b) Give **two** reasons for using LEDs as the light source for the torch.

- 1 .....
  - 2 .....
- ..... [1]
- ..... [1]



(c) The wind up torch, shown in Fig. 3, is to be modified for use by young children.

On Fig. 4 use sketches and notes to show **two** improvements that will make the product better suited to this user group.

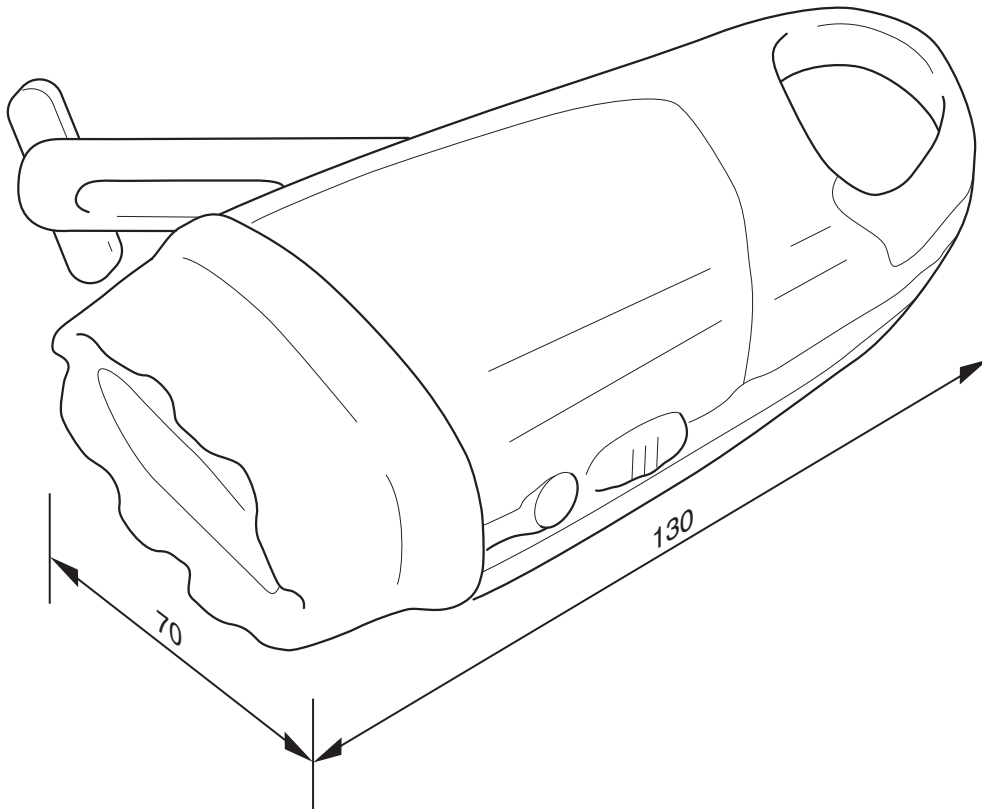

Fig. 4



18 New products such as those in Fig. 5 should be designed to take account of their potential effects on the environment. Sustainability issues should be part of the product specification.

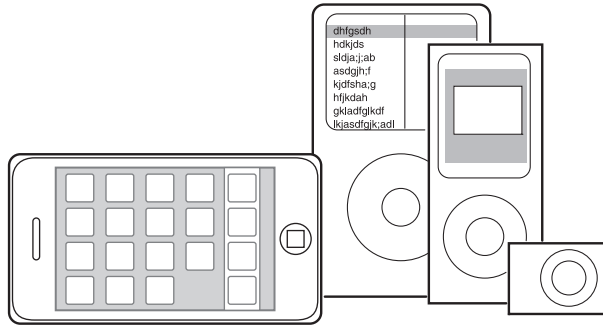

Fig. 5

Describe how the designer should consider the following:

(a) The responsible use of materials

.....

.....

.....

.....

.....

..... [3]

(b) The carbon footprint during manufacture

.....

.....

.....

.....

.....

..... [3]

(c) The use of environmentally friendly packaging

.....

.....

.....

.....

.....

..... [3]

(d) The life-cycle of the product

.....

.....

.....

.....

.....

..... [3]

(e) The disposal and recycling of the product when no longer needed.

.....

.....

.....

.....

.....

..... [3]

**Total [15]**



**Copyright Information**

OCR is committed to seeking permission to reproduce all third-party content that it uses in its assessment materials. OCR has attempted to identify and contact all copyright holders whose work is used in this paper. To avoid the issue of disclosure of answer-related information to candidates, all copyright acknowledgements are reproduced in the OCR Copyright Acknowledgements Booklet. This is produced for each series of examinations, is given to all schools that receive assessment material and is freely available to download from our public website ([www.ocr.org.uk](http://www.ocr.org.uk)) after the live examination series.

If OCR has unwittingly failed to correctly acknowledge or clear any third-party content in this assessment material, OCR will be happy to correct its mistake at the earliest possible opportunity.

For queries or further information please contact the Copyright Team, First Floor, 9 Hills Road, Cambridge CB2 1GE.

OCR is part of the Cambridge Assessment Group; Cambridge Assessment is the brand name of University of Cambridge Local Examinations Syndicate (UCLES), which is itself a department of the University of Cambridge.